

 GOULDS PUMPS

Installation, Operation, and Maintenance Manual

Model 3393

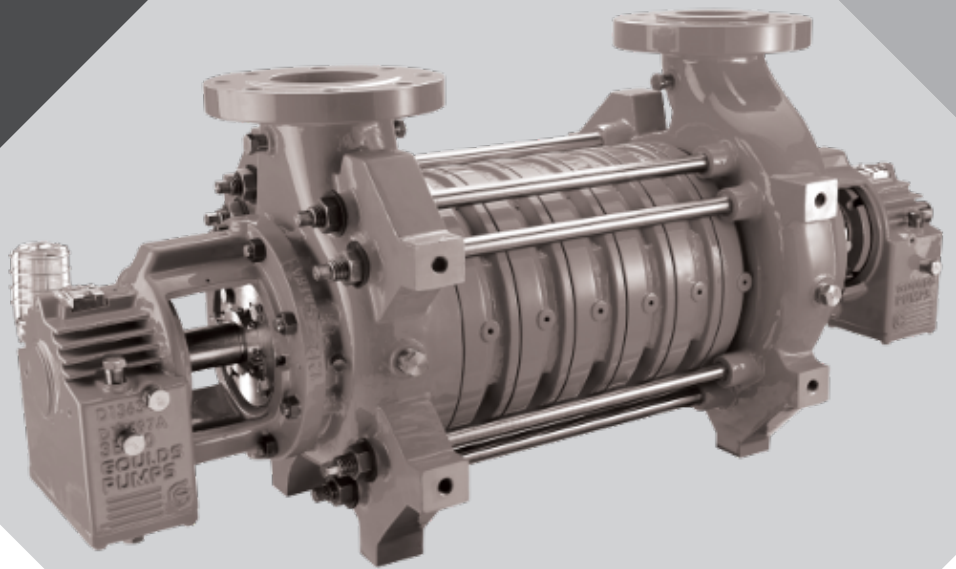

ITT

ENGINEERED FOR LIFE

Table of Contents

Introduction and Safety	4
Introduction	4
Safety	4
Safety terminology and symbols	5
Environmental safety	5
User safety	6
Safety regulations for Ex-approved products in potentially explosive atmospheres	7
Product warranty	8
Transportation and Storage	10
Inspect the delivery	10
Inspect the package	10
Inspect the unit	10
Transportation guidelines	10
Pump handling and lifting	10
Storage guidelines	12
Long-term storage	12
Product Description	13
General description	13
Pump description	14
General description i-ALERT™ Condition Monitor	15
Nameplate information	16
Installation	19
Preinstallation	19
Pump location guidelines	19
Foundation requirements	19
Baseplate-mounting procedures	20
Prepare the baseplate for mounting	20
Prepare the foundation for mounting	21
Install and level the baseplate	21
Install the pump, driver and coupling	22
Pump-to-driver alignment	23
Alignment checks	24
Permitted indicator values for alignment checks	24
Alignment measurement guidelines	25
Attach the dial indicators for alignment	25
Perform angular alignment for a vertical correction	26
Perform angular alignment for a horizontal correction	26
Perform parallel alignment for a vertical correction	27
Perform parallel alignment for a horizontal correction	28
Perform complete alignment for a vertical correction	28
Perform complete alignment for a horizontal correction	29
Grout the baseplate	29
Piping checklists	29
General piping checklist	29
Suction-piping checklist	30
Discharge piping checklist	32
Auxiliary-piping checklist	32
Final piping checklist	33

Commissioning, Startup, Operation, and Shutdown	34
Preparation for startup	34
Remove the coupling guard	35
Check the rotation	35
Couple the pump and driver	36
Coupling guard assembly	37
Bearing lubrication	39
Oil volumes	40
Lubricating oil requirements	40
Lubricate the bearings with oil	40
Purge Oil Mist	41
Lubricate the bearings after a shutdown period	41
Shaft sealing with a mechanical seal	41
Connection of sealing liquid for mechanical seals	42
Prime the pump with the suction supply above the pump	42
Start the pump	42
Activate the i-ALERT Condition Monitor	43
i-ALERT™ Condition Monitor routine operation	44
Pump operation precautions	45
Shut down the pump	46
Deactivate the i-ALERT™ Condition Monitor	46
Reset the i-ALERT™ Condition Monitor	46
Make the final alignment of the pump and driver	46
Maintenance	48
Maintenance precautions	48
Maintenance schedule	48
Bearing maintenance	49
Bearing replacement	49
Maintenance of Bearings	49
Mechanical-seal maintenance	50
Disassembly	50
Introduction	50
Disassembly precautions	51
Required Tools	51
Disassembly	51
Disassembly of suction end bearing	52
Disassembly of discharge end bearing	56
Disassembly of the mechanical seal - end and radial suction pumps	57
Disassembly of the balance drum rotor and stator - end and radial suction pumps	58
Disassembly of complete pump	61
Guidelines for i-ALERT™ Condition Monitor disposal	74
Pre-assembly inspections	74
Preassembly inspections	74
Reassembly	81
Preliminary work	81
Assembly of suction end bearing	81
Assembly of discharge end bearing	85
Assembly of mechanical seal - end and radial suction pumps	87
Assembly of the balance drum rotor and stator - end and radial suction pumps	88
Assembly of complete pump	90
Attach the i-ALERT™ Condition Monitor to the pump	104
Troubleshooting	106
Alignment troubleshooting	106
i-ALERT™ Condition Monitor troubleshooting	106
Operation troubleshooting	107

Parts Listings and Cross-Sectionals	112
Parts	112
Appendix	115
Torque Values	115
Running clearances	115
Maximum allowable forces and moments	116
Tie-Rod Torque Specifications and Procedure	117

Introduction and Safety

Introduction

Purpose of this manual

The purpose of this manual is to provide necessary information for:

- Installation
- Operation
- Maintenance



CAUTION:

Read this manual carefully before installing and using the product. Improper use of the product can cause personal injury and damage to property, and may void the warranty.

NOTICE:

Save this manual for future reference, and keep it readily available at the location of the unit.

Requesting other information

Special versions can be supplied with supplementary instruction leaflets. See the sales contract for any modifications or special version characteristics. For instructions, situations, or events that are not considered in this manual or in the sales documents, please contact the nearest ITT representative.

Always specify the exact product type and identification code when requesting technical information or spare parts.

Safety



WARNING:

- The operator must be aware of safety precautions to prevent physical injury.
 - Any pressure-containing device can explode, rupture, or discharge its contents if it is over-pressurized. Take all necessary measures to avoid over-pressurization.
 - Operating, installing, or maintaining the unit in any way that is not covered in this manual could cause death, serious personal injury, or damage to the equipment. This includes any modification to the equipment or use of parts not provided by ITT. If there is a question regarding the intended use of the equipment, please contact an ITT representative before proceeding.
 - This manual clearly identifies accepted methods for disassembling units. These methods must be adhered to. Trapped liquid can rapidly expand and result in a violent explosion and injury. Never apply heat to impellers, propellers, or their retaining devices to aid in their removal unless explicitly stated in this manual.
 - Do not change the service application without the approval of an authorized ITT representative.
-



CAUTION:

You must observe the instructions contained in this manual. Failure to do so could result in physical injury, damage, or delays.



Safety terminology and symbols

About safety messages

It is extremely important that you read, understand, and follow the safety messages and regulations carefully before handling the product. They are published to help prevent these hazards:

- Personal accidents and health problems
- Damage to the product
- Product malfunction

Hazard levels

Hazard level	Indication
 DANGER:	A hazardous situation which, if not avoided, will result in death or serious injury
 WARNING:	A hazardous situation which, if not avoided, could result in death or serious injury
 CAUTION:	A hazardous situation which, if not avoided, could result in minor or moderate injury
NOTICE:	<ul style="list-style-type: none"> • A potential situation which, if not avoided, could result in undesirable conditions • A practice not related to personal injury

Hazard categories

Hazard categories can either fall under hazard levels or let specific symbols replace the ordinary hazard level symbols.

Electrical hazards are indicated by the following specific symbol:



Electrical Hazard:

These are examples of other categories that can occur. They fall under the ordinary hazard levels and may use complementing symbols:

- Crush hazard
- Cutting hazard
- Arc flash hazard

The Ex symbol

The Ex symbol indicates safety regulations for Ex-approved products when used in atmospheres that are potentially explosive or flammable.



Environmental safety

The work area

Always keep the station clean to avoid and/or discover emissions.

Waste and emissions regulations

Observe these safety regulations regarding waste and emissions:

- Appropriately dispose of all waste.
- Handle and dispose of the processed liquid in compliance with applicable environmental regulations.
- Clean up all spills in accordance with safety and environmental procedures.
- Report all environmental emissions to the appropriate authorities.



WARNING:

Do NOT send the product to the ITT manufacturer if it has been contaminated by any nuclear radiation. Inform ITT so that accurate actions can take place.

Electrical installation

For electrical installation recycling requirements, consult your local electric utility.

Recycling guidelines

Always follow local laws and regulations regarding recycling.

User safety

General safety rules

These safety rules apply:

- Always keep the work area clean.
- Pay attention to the risks presented by gas and vapors in the work area.
- Avoid all electrical dangers. Pay attention to the risks of electric shock or arc flash hazards.
- Always bear in mind the risk of drowning, electrical accidents, and burn injuries.

Safety equipment

Use safety equipment according to the company regulations. Use this safety equipment within the work area:

- Helmet
- Safety goggles, preferably with side shields
- Protective shoes
- Protective gloves
- Gas mask
- Hearing protection
- First-aid kit
- Safety devices

NOTICE:

Never operate a unit unless safety devices are installed. Also see specific information about safety devices in other chapters of this manual.

Electrical connections

Electrical connections must be made by certified electricians in compliance with all international, national, state, and local regulations. For more information about requirements, see sections dealing specifically with electrical connections.

Precautions before work

Observe these safety precautions before you work with the product or are in connection with the product:

- Provide a suitable barrier around the work area, for example, a guard rail.
- Make sure that all safety guards are in place and secure.
- Make sure that you have a clear path of retreat.
- Make sure that the product cannot roll or fall over and injure people or damage property.
- Make sure that the lifting equipment is in good condition.
- Use a lifting harness, a safety line, and a breathing device as required.
- Allow all system and pump components to cool before you handle them.
- Make sure that the product has been thoroughly cleaned.
- Disconnect and lock out power before you service the pump.
- Check the explosion risk before you weld or use electric hand tools.

Wash the skin and eyes

1. Follow these procedures for chemicals or hazardous fluids that have come into contact with your eyes or your skin:

Condition	Action
Chemicals or hazardous fluids in eyes	<ol style="list-style-type: none"> 1. Hold your eyelids apart forcibly with your fingers. 2. Rinse the eyes with eyewash or running water for at least 15 minutes. 3. Seek medical attention.
Chemicals or hazardous fluids on skin	<ol style="list-style-type: none"> 1. Remove contaminated clothing. 2. Wash the skin with soap and water for at least 1 minute. 3. Seek medical attention, if necessary.

Safety regulations for Ex-approved products in potentially explosive atmospheres

Description of ATEX

The ATEX directives are a specification enforced in Europe for electrical and non-electrical equipment. ATEX deals with the control of potentially explosive atmospheres and the standards of equipment and protective systems used within these atmospheres. The relevance of the ATEX requirements is not limited to Europe. You can apply these guidelines to equipment installed in any potentially explosive atmosphere.

Guidelines for compliance

NOTICE: This manual clearly identifies accepted methods for disassembling units. These methods must be adhered to. Trapped liquid can rapidly expand and result in a violent explosion and injury. Never apply heat to impellers, propellers, or their retaining devices to aid in their removal. If there are any questions regarding these requirements, the intended use, or if the equipment requires modification, contact an ITT representative before you proceed.

Compliance is only fulfilled when the pump is operated within its intended use, for example within its intended hydraulic range. The conditions of the service must not be changed without approval of an authorized ITT representative. When installing or maintaining explosion-proof pumps, follow these guidelines:

- Always install ATEX-approved equipment in compliance with the directive and applicable standards (IEC/EN 60079–14).
- Do not install explosion proof products in locations that are classified as hazardous in the national electric code, ANSI/NFPA 70–2005.

Personnel requirements

ITT disclaims all responsibility for work done by untrained and unauthorized personnel.

These are the personnel requirements for Ex-approved products in potentially explosive atmospheres:

- All work on the product must be carried out by certified electricians and ITT-authorized mechanics. Special rules apply to installations in explosive atmospheres.
- All users must know about the risks of electric current and the chemical and physical characteristics of the gas and/or vapor present in hazardous areas.
- Any maintenance for Ex-approved products must conform to international and national standards (for example IEC/EN 60079-17).

Product and product handling requirements

These are the product and product handling requirements for Ex-approved products in potentially explosive atmospheres:

- Only use the product in accordance with the approved motor data stated on the nameplates.
- The Ex-approved product must never run dry during normal operation. Dry running during service and inspection is only permitted outside the classified area.
- Never start a pump without the proper priming.
- Before you start working with the product, make sure that the product and the control panel are isolated from the power supply and the control circuit, so they cannot be energized.
- Do not open the product while it is energized or in an explosive gas atmosphere.
- Make sure that thermal contacts are connected to a protection circuit according to the approval classification of the product.
- Intrinsically safe circuits are normally required for the automatic level-control system by the level regulator if mounted in zone 0.
- The yield stress of fasteners must be in accordance with the approval drawing and the product specification.
- Do not modify the equipment without approval from an authorized ITT representative.
- Only use parts that have been provided by an authorized ITT representative.

Equipment for monitoring

For additional safety, use condition-monitoring devices. Condition-monitoring devices include but are not limited to these devices:

- Pressure gauges
- Flow meters
- Level indicators
- Motor load readings
- Temperature detectors
- Bearing monitors
- Leak detectors
- PumpSmart control system

Product warranty

Coverage

ITT undertakes to remedy faults in products from ITT under these conditions:

- The faults are due to defects in design, materials, or workmanship.
- The faults are reported to an ITT representative within the warranty period.
- The product is used only under the conditions described in this manual.
- The monitoring equipment incorporated in the product is correctly connected and in use.
- All service and repair work is done by ITT-authorized personnel.

- Genuine ITT parts are used.
- Only Ex-approved spare parts and accessories authorized by ITT are used in Ex-approved products.

Limitations

The warranty does not cover faults caused by these situations:

- Deficient maintenance
- Improper installation
- Modifications or changes to the product and installation made without consulting ITT
- Incorrectly executed repair work
- Normal wear and tear

ITT assumes no liability for these situations:

- Bodily injuries
- Material damages
- Economic losses

Warranty claim

ITT products are high-quality products with expected reliable operation and long life. However, should the need arise for a warranty claim, then contact your ITT representative.

Transportation and Storage

Inspect the delivery

Inspect the package

1. Inspect the package for damaged or missing items upon delivery.
2. Note any damaged or missing items on the receipt and freight bill.
3. File a claim with the shipping company if anything is out of order.
If the product has been picked up at a distributor, make a claim directly to the distributor.

Inspect the unit

1. Remove packing materials from the product.
Dispose of all packing materials in accordance with local regulations.
2. Inspect the product to determine if any parts have been damaged or are missing.
3. If applicable, unfasten the product by removing any screws, bolts, or straps.
For your personal safety, be careful when you handle nails and straps.
4. Contact your sales representative if anything is out of order.

Transportation guidelines

Pump handling and lifting

Precautions for moving the pump

Use care when moving pumps. Consult with a lifting and rigging specialist before lifting or moving the pump to avoid possible damage to the pump or injury to personnel.



WARNING:

Make sure that the unit cannot roll or fall over and injure people or damage property.

NOTICE:

Use a forklift truck with sufficient capacity to move the pallet with the pump unit on top.

Precautions for lifting the pump



WARNING:

Crush hazard. The unit and the components can be heavy. Use proper lifting methods and wear steel-toed shoes at all times. Assembled units and their components are heavy. Failure to properly lift and support the equipment can result in serious physical injury and/or equipment damage. Lift equipment only at the specifically identified lifting points. Lifting devices such as eye bolts, slings and spreaders must be rated, selected and used for the entire load being lifted.

NOTICE:

- Make sure that the lifting equipment supports the entire assembly and is only used by authorized personnel.
 - Do not attach sling ropes to shaft ends.
-

Lifting the pump

Hoist a bare pump using suitable slings under the bearing housing saddle on each end.

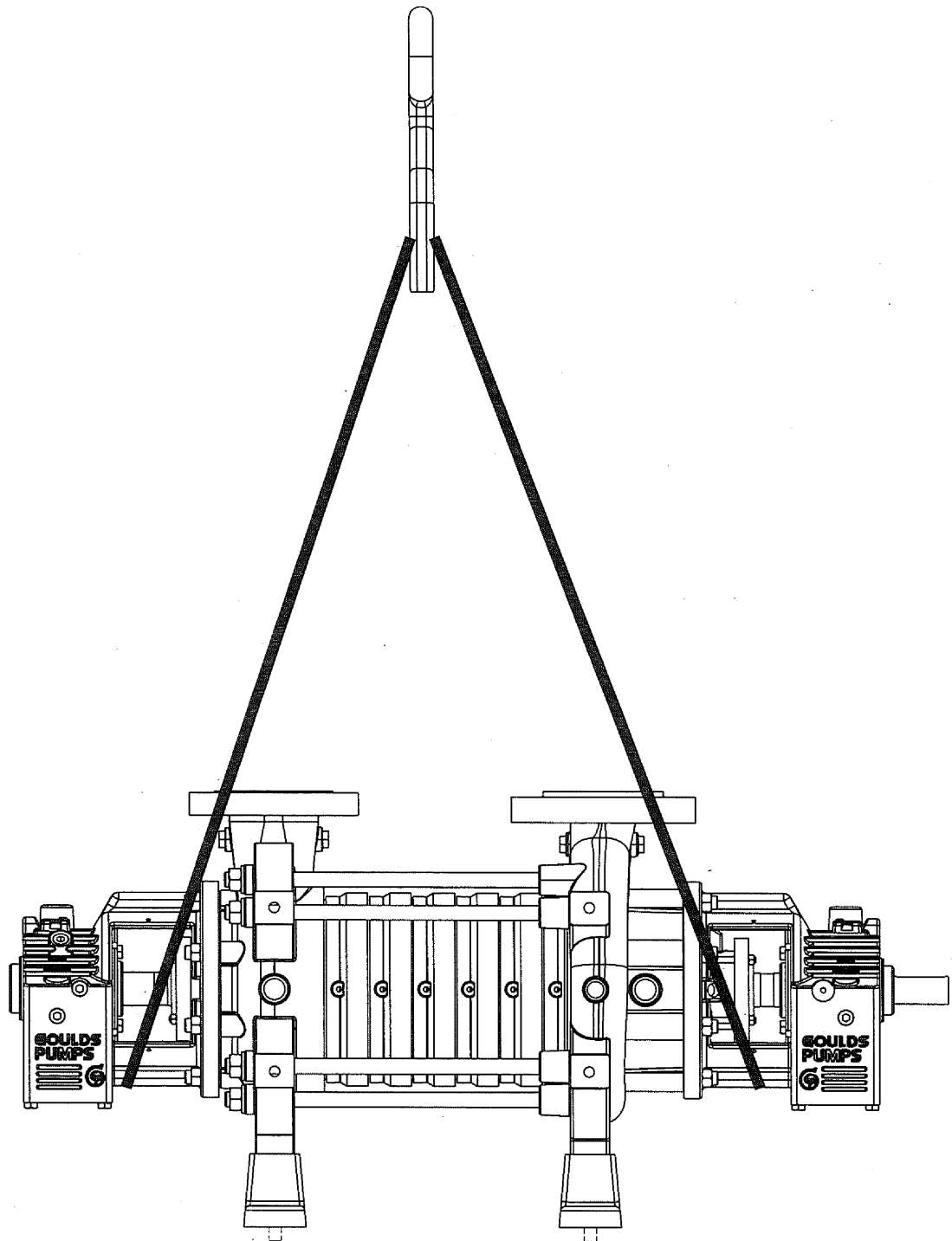

Figure 1: Example of the proper lifting method for a bare pump
 Baseplate-mounted units have lifting points for use with proper lifting devices.

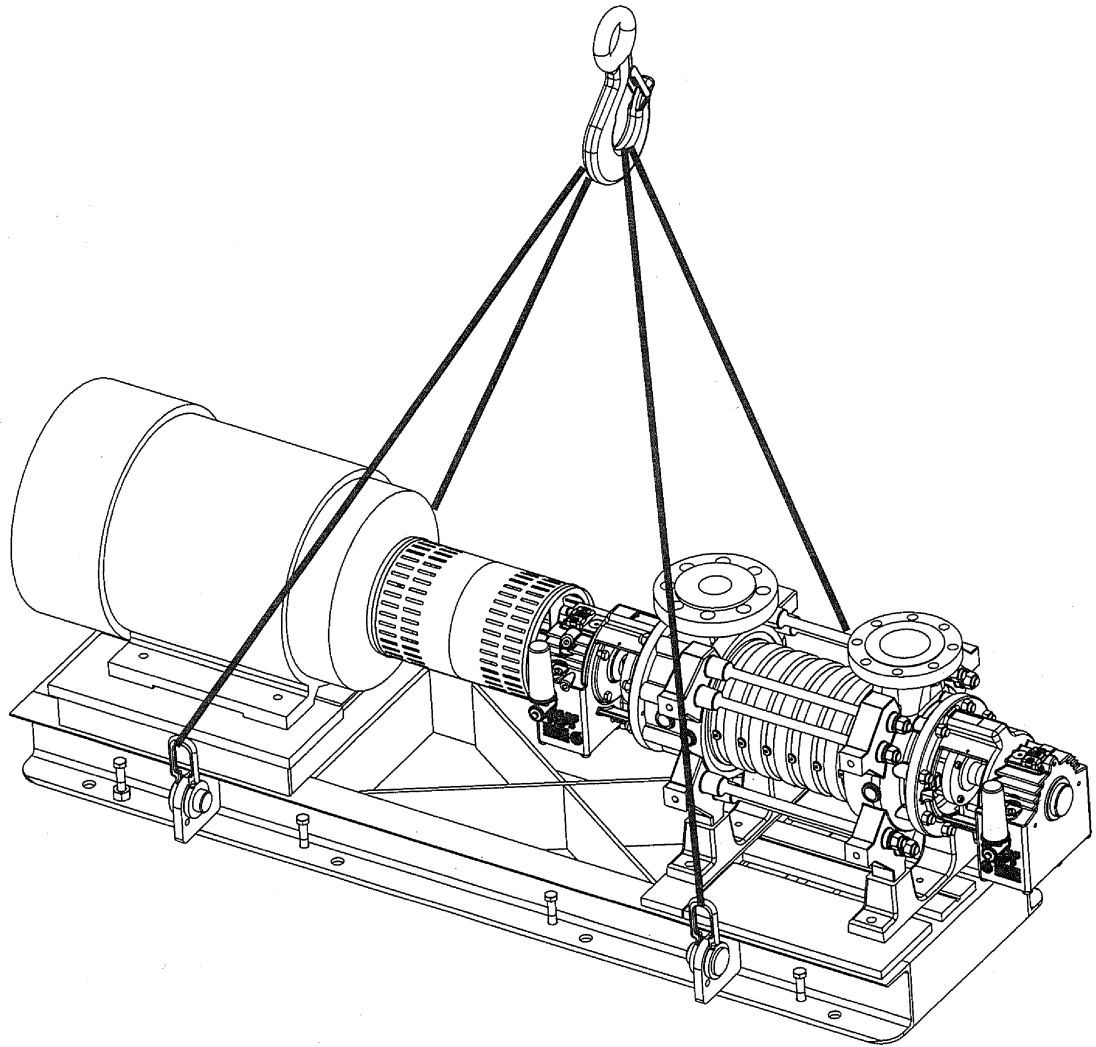

Figure 2: Example of the proper lifting method for baseplate-mounted units

Storage guidelines

Long-term storage

If the unit is stored for more than 6 months, these requirements apply:

- Store in a covered and dry location.
- Store the unit free from heat, dirt, and vibrations.
- Rotate the shaft by hand several times at least every three months.

Treat bearing and machined surfaces so that they are well preserved. Refer to the drive unit and coupling manufacturers for their long-term storage procedures.

For questions about possible long-term storage treatment services, please contact your local ITT sales representative.

Product Description

General description

The Model 3393 is a radially split, segmented casing, multistage pump with these characteristics:

- Modular interstage components
- Varying numbers of stages, hydraulics, materials, and configurations
- Multiple suction nozzle and discharge nozzle orientations.
- Multiple hydraulics for each pump size

Radial suction configuration features radial suction and discharge nozzles. The suction and discharge nozzles can be positioned either vertical or horizontally at 90° to either side. This design consists of two robust, finned bearing housings with traditional anti-friction bearings and mechanical seals on each end of the pump.

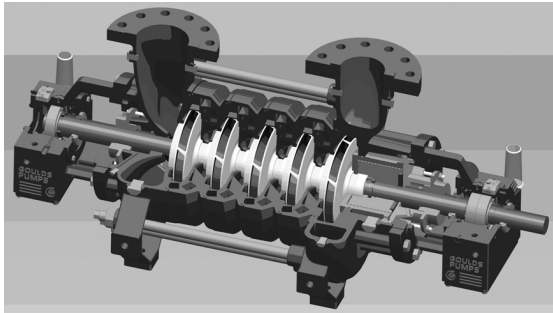

Figure 3: Radial suction design

End suction configuration features an end suction nozzle in conjunction with a radial discharge nozzle. The suction end of the pump utilizes a product-lubricated bearing eliminating the need for a second bearing housing and mechanical seal. Because of the positioning of the sleeve bearing in the end suction casing, the suction flange size is one size larger than the size for the radial suction arrangement. The discharge nozzle can be positioned either vertically or horizontally at 90° to either side.

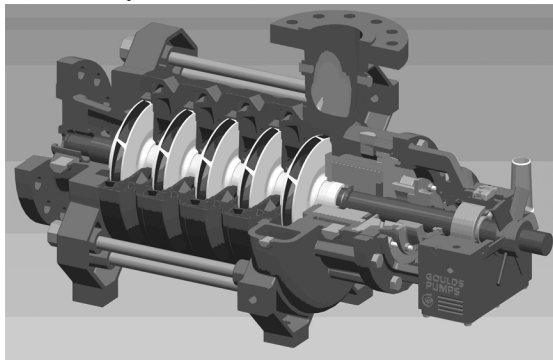

Figure 4: End suction design

Casing

The pressure boundary consists of three basic casings and a mechanical seal chamber.

- The suction casing is available in an end or radial suction arrangement and is rated to a lower pressure than the interstage or discharge casings.
- The interstage casings are combined with the diffuser into a single piece and are rated to the full discharge pressure.
- The discharge casing is of dual volute construction.

Flange ratings

Flange Options
Suction
ANSI B16.5 150 lb RF / ISO 7005-1 PN 20
ANSI B16.5 300 lb RF / ISO 7005-1 PN 50
EN 1092-1 PN 40
Discharge
EN 1092-1 PN 63
ANSI B16.5 600 lb RF / ISO 7005-1 PN 110
EN 1092-1 PN 100
ANSI B16.5 900 lb RF / ISO 7005-1 PN 150 (12 Chrome casing only)

Impeller

The impeller is a single suction, enclosed impeller. It is keyed to the shaft.

Seal chamber

The seal chamber accepts single or double cartridge seals and various piping plans. It is dimensioned based on DIN 24960.

Bearing frame and bearings

The bearing frame is cast iron, finned for additional cooling and oil lubricated. Bearings are as noted in the following table.

Pump Size	2.5x4-8	4x5-10	5x6-11	6x8-13
Bearing - driver end (thrust)	7408	7409	7311	7214
Bearing - outboard (ES) (radial)	SiC/SiC	SiC/SiC	SiC/SiC	SiC/SiC
Bearing - outboard (RS) (radial)	6408	6409	6311	6214

Shaft

The shaft is of heavy-duty construction of 17-4 pH or super duplex depending on the casing material. It is designed for cartridge mechanical seals to limit shaft deflection to .002 in. (0.051 mm) at worst case condition.

Baseplate

The baseplate is of fabricated steel and supports the pump, driver, and any accessories.

Pump description

The **Goulds Model 3393** is a radially split, segmented casing, multistage pump designed with modular interstage components. These identical components can be assembled to produce pumps of varying numbers of stages, hydraulics, materials, and configurations to meet the customer's specific requirements. Its multiple suction nozzle and discharge nozzle orientations allow the 3393 to adapt to multiple piping installations and provide the piping designer with flexibility in plant layout. Multiple hydraulics for each pump size optimize efficiency across a vast range of applications. All intermediate stage components are identical which reduces spare parts inventory.

The 3393 is designed as a two-pole speed pump. There will be times when the pump will be operated at variable speed. The 3393 can be operated between 2700 and 3600 rpm without reference to the factory. At speeds above 3600 rpm and below 2700 rpm, a lateral critical speed analysis must be conducted by the factory. Contact your local representative for pricing. In all cases it is imperative that the pump be brought up to its minimum operating speed as quickly as possible. This ramp up time should not exceed 5 seconds.

RS - Radial Suction configuration features radial suction and discharge nozzles. The suction and discharge nozzles can be positioned either vertically or horizontally at 90° to either side. This design consists of two robust, finned bearing housings with traditional anti-friction bearings and mechanical seals on each end of the pump.

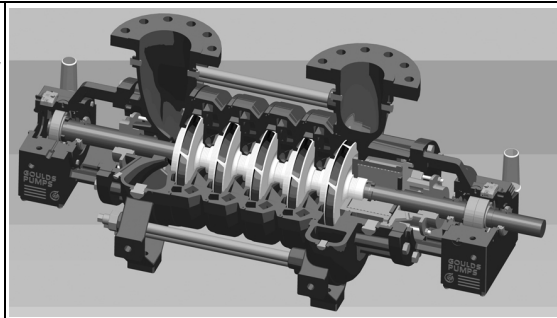

ES - End Suction configuration features an end suction nozzle in conjunction with a radial discharge nozzle. The suction end of the pump utilizes a product-lubricated bearing eliminating the need for a second bearing housing and mechanical seal. Because of the positioning of the sleeve bearing in the end suction casing, the suction flange size is one size larger than the size for the radial suction arrangement. The discharge nozzle can be positioned either vertically or horizontally at 90° to either side.

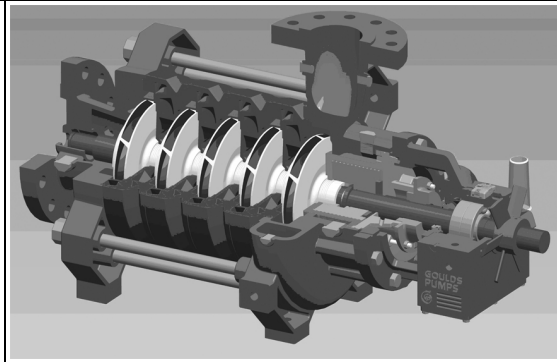

General description i-ALERT™ Condition Monitor

Description

The i-ALERT Condition Monitor is a compact, battery-operated monitoring device that continuously measures the vibration and temperature of the pump power end. The condition monitor uses blinking red LEDs to alert the pump operator when the pump exceeds pre-set vibration and temperature limits. This allows the pump operator to make changes to the process or the pump before a catastrophic failure occurs. The condition monitor is also equipped with a single green LED to indicate when it is operational and has sufficient battery life.

Software License Agreement

BY USING THE i-Alert™ CONDITION MONITOR, YOU AGREE TO BE BOUND BY THE TERMS AND CONDITIONS OF THE FOLLOWING LICENSE AGREEMENT. PLEASE READ THIS AGREEMENT CAREFULLY.

ITT Corporation and its subsidiaries, affiliates, either directly, or through its authorized sublicensees ("ITT") grants you a limited, non-exclusive license to use the software embedded in this device ("Software") in binary executable form in the normal operation of the i-Alert™ condition monitor for monitoring the condition of an Goulds Pump Inc. model. Title, ownership rights, and intellectual property rights in and to the Software remain in ITT or its third-party providers. You agree that this license agreement does not need to be signed for it to take effect.

You acknowledge that this Software is the property of ITT and is protected under United States of America copyright laws and international copyright treaties. You further acknowledge that the structure, organization, and code of the Software are valuable trade secrets of ITT and/or its third-party providers and that the Software in source code form remains a valuable trade secret of ITT. You agree not to decompile, disassemble, modify, reverse assemble, reverse engineer, or reduce to human readable form the Software or any part thereof or create any derivative works based on the Software. You agree not to export or re-export the Software to any country in violation of the export control laws of the United States of America.

Alarm mode

The condition monitor enters alarm mode when either vibration or temperature limits are exceeded over two consecutive readings within a ten minute period. Alarm mode is indicated with two red flashing LEDs within two second intervals.

Temperature and vibration limits

Variable	Limit
Temperature	195°F (91°C)
Vibration	100% increase over the baseline level

Battery life

The i-ALERT Condition Monitor battery is not replaceable. You must replace the entire unit once the battery runs out of power.

The battery life is not covered as part of the standard five-year pump warranty.

This table shows the average condition monitor battery life under normal and alarm-mode operating conditions.

Condition monitor operational state	Battery life
Normal operating and environmental conditions	Three to five years
Alarm mode	One year

Nameplate information**Important information for ordering**

Every pump has a nameplate that provides information about the pump. The nameplate is located on the pump casing.

When you order spare parts, identify this pump information:

- Model
- Size
- Serial number
- Item numbers of the required parts

Nameplate types

Nameplate	Description
Pump casing	Provides information about the hydraulic characteristics of the pump. The formula for the pump size is: Discharge x Suction - Nominal Maximum Impeller Diameter in inches. (Example: 2x3-8)
Bearing frame	Provides information about the lubrication system used.
ATEX	If applicable, your pump unit might have an ATEX nameplate affixed to the pump, the baseplate, or the discharge head. The nameplate provides information about the ATEX specifications of this pump.
IECEX	If applicable, your pump unit might have the following IECEX nameplate affixed to the pump and/or baseplate. The nameplate provides information about the IECEX specifications of this pump.
Other	If applicable, additional information, warnings or cautions may be noted.

Nameplate on the pump casing using English units

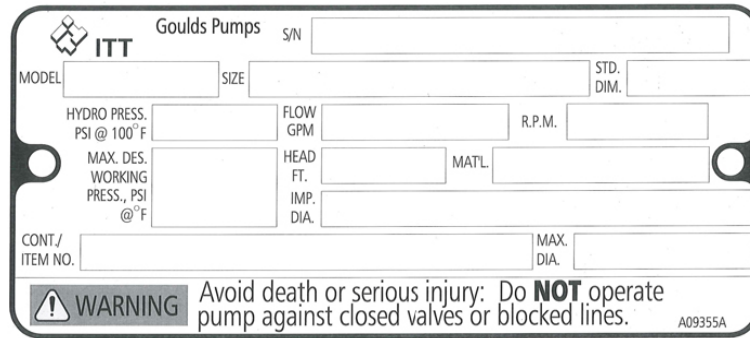

Table 1: Explanation of nameplate on the pump casing

Nameplate field	Explanation
S/N	Goulds serial number
Model	Pump model
Size	Size of the pump
Std. Dim	Standard Dimensional designation
Hydro Pressure	Hydrostatic pressure at 70°F, in pounds per square inch
Max. Design Working Press.	Maximum working pressure in pounds per square inch
RPM	Rated pump speed, in revolutions per minute
Head	Rated pump head in feet
Material	Pump material
Impeller Diameter	Impeller trim diameter
Cont/Item No	Purchaser's contract or item number
Max. Dia	Impeller maximum diameter

Nameplate on the bearing frame

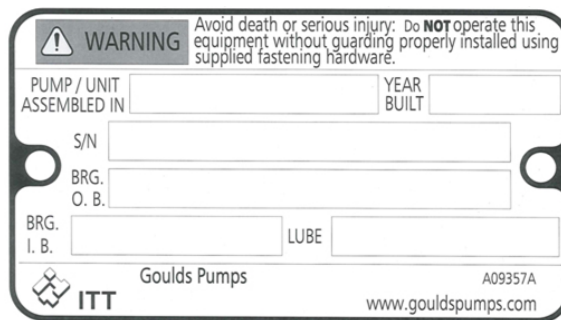

Table 2: Explanation of the nameplate on the bearing frame

Nameplate field	Explanation
Assembled in	Country in which final unit built
Year built	Year in which final unit built
S/N	Serial number
Bearing O.B.	Outboard bearing number/designation
Bearing I.B.	Inboard bearing number/designation
Lubrication	Type of lubrication of pump

ATEX nameplate



Nameplate field	Explanation
II	Group 2
2	Category 2
G/D	Pump can be used when gas and dust are present
T4	Temperature class

NOTICE:

Make sure that the code classifications on the pump are compatible with the specific environment in which you plan to install the equipment. If they are not compatible, do not operate the equipment and contact your ITT representative before you proceed.

Warning nameplate

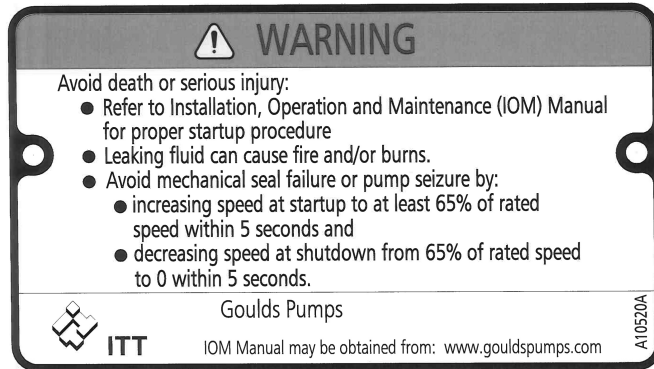

The nameplate shown is the standard warning and is applicable for most pumps. You must refer to the startup procedures in the IOM for any specific instructions that may be different. The instructions in the IOM will take precedence.

Installation

Preinstallation

 Equipment that will operate in a potentially explosive environment must be installed in accordance with the following instructions.

Precautions



WARNING:

- When installing in a potentially explosive environment, make sure that the motor is properly certified and that all equipment is installed in accordance with appropriate instructions for that environment.
- You must earth (ground) all equipment. This applies to the pump equipment, the driver, and any monitoring equipment. Test the earth (ground) lead to verify that it is connected correctly.

NOTICE:

Supervision by an authorized ITT representative is recommended to ensure proper installation. Failure to do so may result in equipment damage or decreased performance.

Pump location guidelines



WARNING:

Assembled units and their components are heavy. Failure to properly lift and support this equipment can result in serious physical injury and/or equipment damage. Lift equipment only at the specifically identified lifting points. Lifting devices such as eyebolts, slings, and spreaders must be rated, selected, and used for the entire load being lifted.

Guideline	Explanation/comment
Make sure that the space around the pump is sufficient.	This facilitates ventilation, inspection, maintenance, and service.
If you require lifting equipment such as a hoist or tackle, make sure that there is enough space above the pump.	This makes it easier to properly use the lifting equipment and safely remove and relocate the components to a safe location.
Protect the unit from weather and water damage due to rain, flooding, and freezing temperatures.	This is applicable if nothing else is specified.
Do not install and operate the equipment in closed systems unless the system is constructed with properly-sized safety devices and control devices.	Acceptable devices: <ul style="list-style-type: none"> • Pressure relief valves • Compression tanks • Pressure controls • Temperature controls • Flow controls If the system does not include these devices, consult the engineer or architect in charge before you operate the pump.
Take into consideration the occurrence of unwanted noise and vibration.	The best pump location for noise and vibration absorption is on a concrete floor with subsoil underneath.

Foundation requirements

Requirements

- The foundation must be able to absorb any type of vibration and form a permanent, rigid support for the unit.
- Provide a flat, substantial concrete foundation in order to prevent strain and distortion when you tighten the foundation bolts.
- Sleeve-type and J-type foundation bolts are most commonly used. Both designs allow movement for the final bolt adjustment.

Sleeve-type bolts

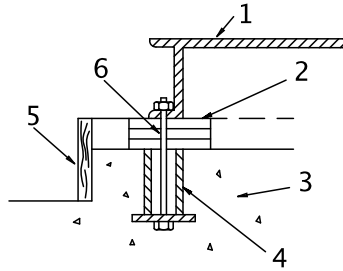

1. Baseplate
2. Shims or wedges
3. Foundation
4. Sleeve
5. Dam
6. Bolt

J-type bolts

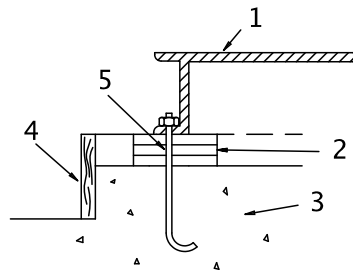

1. Baseplate
2. Shims or wedges
3. Foundation
4. Dam
5. Bolt

Baseplate-mounting procedures

Prepare the baseplate for mounting

This procedure assumes you have a basic knowledge of baseplate and foundation design and installation methods. Follow industry-standard procedures, such as API RP 686/ PIP REIE 686, or this procedure before you grout the baseplate.

1. Make sure that all baseplate surfaces that will contact grout are free from contamination such as rust, oil, and grime.
2. Thoroughly clean all baseplate surfaces that will come in contact with grout. Make sure to use a cleaner that will not leave residue.

NOTICE:

You may need to sandblast the surfaces of a baseplate that come in contact with grout, and then coat those surfaces with a primer that is grout-compatible. Make sure to remove all equipment before sandblasting.

3. Make sure that all machined surfaces are free from burrs, rust, paint, or any other type of contamination. If necessary, use a honing stone to remove burrs.

Prepare the foundation for mounting

1. Chip the top of the foundation to a minimum of 1.0 in. (25.0 mm) in order to remove porous or low-strength concrete.
If you use a pneumatic hammer, make sure that it does not contaminate the surface with oil or other moisture.

NOTICE:

Do not chip the foundation using heavy tools such as jackhammers. This can damage the structural integrity of the foundation.

2. Remove water or debris from the foundation bolt holes or sleeves.
3. If the baseplate uses sleeve-type bolts, then fill the sleeves with a non-binding, moldable material. Seal the sleeves in order to prevent the grout from entering.
4. Coat the exposed portion of the anchor bolts with a non-binding compound such as paste wax in order to prevent the grout from adhering to the anchor bolts.
Do not use oils or liquid wax.
5. If recommended by the grout manufacturer, coat the foundation surface with a compatible primer.

Install and level the baseplate

NOTICE: Illustrations are for reference only and may not depict the particular pump model.

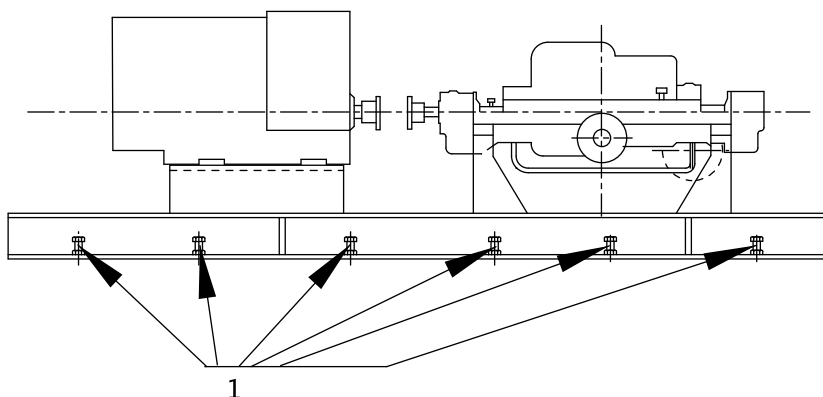

1. Jackscrews

Figure 5: Jackscrew locations, side view

1. Jackscrews

Figure 6: Jackscrew locations, top view

1. Lower the baseplate carefully onto the foundation bolts.
The baseplate will rest on top of the foundation on the jackscrews provided on the baseplate.
2. Adjust the leveling jackscrews, located adjacent to the foundation bolt holes, until the baseplate rests 1 to 2 in. (25 to 50 mm) above the foundation in order to allow for adequate grouting.
This provides even support for the baseplate after grouting.
3. Level the baseplate to within 0.002 in./ft. (0.167 mm/m) of the length or width of the baseplate by adjusting the jackscrews.
 - The maximum total variation from one end or side of the baseplate to the other is 0.015 in. (0.38 mm).
 - Use the equipment mounting surfaces in order to establish the level.
4. Use a non-bonding (anti-seize) compound such as paste wax to coat the portions of the jackscrews that will contact the grout.

This facilitates removal of the screws after grouting.

NOTICE:

Do not use oils or liquid wax.

5. Thread the nuts onto the foundation bolts and hand-tighten.

Install the pump, driver and coupling

1. Mount and fasten the pump on the baseplate. Use applicable bolts.
-

NOTICE: Two tapered dowel pins are provided in case there is a need to provide repeatable location between the pump and base plate. Installation of the dowel pins is not mandatory.

2. Mount the driver on the baseplate.
3. Install the coupling. See the installation instructions from the coupling manufacturer.
4. If the pump baseplate has a slot for high temperature dowelling the following must be performed after final alignment.
 - a) Verify that the parallel dowel has been installed in the center of the pump foot furthest from the drive end. It should locate fully in a slot parallel to the shaft that has been machined in the base plate.
 - b) Torque the bolts closest to the driver to the standard values.
 - c) Torque the bolts on the outboard end to 15% of the standard value. This will allow the pump to expand axially with increasing temperature while maintaining pump to driver alignment.
5. If repeatable location of the pump to base plate is desired perform either 5.a. or 5.b.
 - a) For pumps without high temperature doweling, drill through each pump foot (drive end and non drive end), into the base plate then taper ream to suit the supplied taper dowel pins.
 - b) For pumps fitted with high temperature doweling, drill through the drive end pump foot into the base plate then taper ream to suit the supplied taper dowel pin. Discard the unused taper dowel pin.

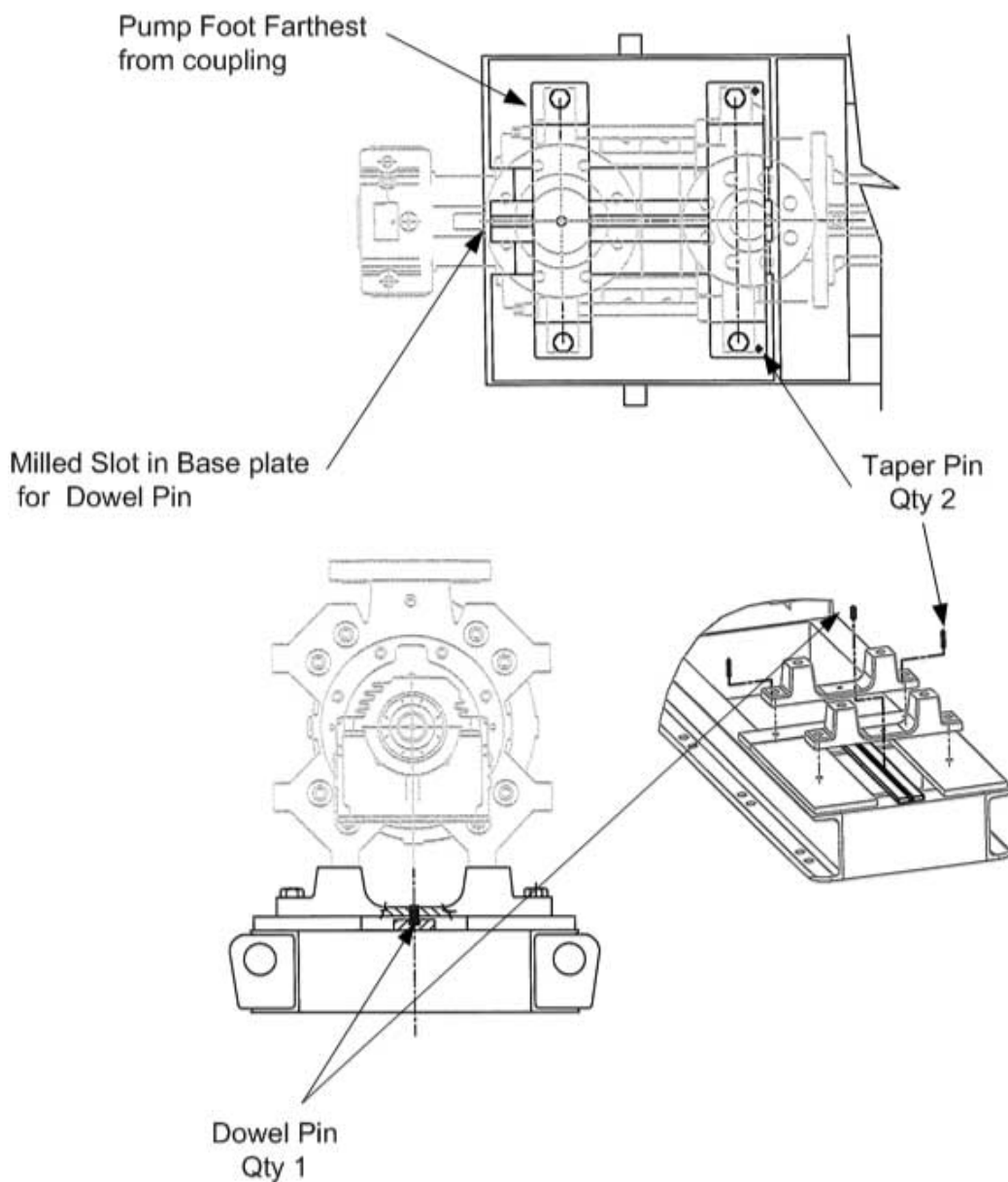

Pump-to-driver alignment

 Alignment procedures must be followed to prevent unintended contact of rotating parts. Follow coupling manufacturer's installation and operation procedures.

Precautions



WARNING:

- Follow shaft alignment procedures in order to prevent catastrophic failure of drive components or unintended contact of rotating parts. Follow the coupling installation and operation procedures from the coupling manufacturer.
- Always disconnect and lock out power to the driver before you perform any installation or maintenance tasks. Failure to disconnect and lock out driver power will result in serious physical injury.

NOTICE:

Proper alignment is the responsibility of the installer and the user of the unit. Check the alignment of frame-mounted units before you operate the unit. Failure to do so can result in equipment damage or decreased performance.

Alignment methods

Three common alignment methods are used:

- Dial indicator
- Reverse dial indicator
- Laser

Follow the instructions from the equipment manufacturer when you use the reverse dial indicator or laser methods. Detailed instructions for using the dial indicator method are contained in this chapter.

Alignment checks

When to perform alignment checks

You must perform alignment checks under these circumstances:

- The process temperature changes.
- The piping changes.
- The pump has been serviced.

Types of alignment checks

Type of check	When it is used
Initial alignment (cold alignment) check	Prior to operation when the pump and the driver are at ambient temperature.
Final alignment (hot alignment) check	After operation when the pump and the driver are at operating temperature.

Initial alignment (cold alignment) checks

When	Why
Before you grout the baseplate	This ensures that alignment can be accomplished.
After you grout the baseplate	This ensures that no changes have occurred during the grouting process.
After you connect the piping	This ensures that pipe strains have not altered the alignment. If changes have occurred, you must alter the piping to remove pipe strains on the pump flanges.

Final alignment (hot alignment) checks

When	Why
After the first run	This ensures correct alignment when both the pump and the driver are at operating temperature.
Periodically	This follows the plant operating procedures.

Permitted indicator values for alignment checks

NOTICE:

The specified permitted reading values shown in the tables are valid only for motors with the temperature rise noted. For other drivers such as steam turbines, engines or motors with a different temperature rise, the correct settings must be recalculated. If the pump is driven through a speed reduction or speed increasing gear, contact the factory. You must use the correct tolerances. Failure to do so can result in misalignment and reduced pump reliability.

Alignment Criteria: Cold parallel vertical alignment setting

NOTICE: A positive value indicates that the pump shaft should be set higher than the motor shaft; a negative value indicates that the pump shaft should be set lower than the motor shaft.

Table 3: Pump operating temperature for 2.5x4-8 and 2.5x5-8

Motor Temperature Rise	English units (inches)				Metric units (mm)			
	<100°F	100-200°F	201-300°F	301-400°F	<38°C	38-93°C	94-149°C	150-204°C
104°F (40°C)	0.004	0.000	-0.009	-0.018	0.11	0.00	-0.23	-0.46
122°F (50°C)	0.006	0.001	-0.007	-0.017	0.15	0.04	-0.19	-0.42

Table 4: Pump operating temperature for 4x5-10 and 4x6-10

Motor Temperature Rise	English units (inches)				Metric units (mm)			
	<100°F	100-200°F	201-300°F	301-400°F	<38°C	38-93°C	94-149°C	150-204°C
104°F (40°C)	0.005	0.000	-0.010	-0.021	0.13	0.00	-0.26	-0.53
122°F (50°C)	0.007	0.002	-0.009	-0.019	0.17	0.04	-0.22	-0.48

Table 5: Pump operating temperature for 5x6-11 and 5x8-11

Motor Temperature Rise	English units (inches)				Metric units (mm)			
	<100°F	100-200°F	201-300°F	301-400°F	<38°C	38-93°C	94-149°C	150-204°C
104°F (40°C)	0.006	0.000	-0.012	-0.023	0.14	-0.01	-0.30	-0.59
122°F (50°C)	0.008	0.002	-0.010	-0.021	0.20	0.05	-0.24	-0.54

Table 6: Pump operating temperature for 6x8-13 and 6x10-13

Motor Temperature Rise	English units (inches)				Metric units (mm)			
	<100°F	100-200°F	201-300°F	301-400°F	<38°C	38-93°C	94-149°C	150-204°C
104°F (40°C)	0.006	0.000	-0.013	-0.027	0.16	-0.01	-0.34	-0.68
122°F (50°C)	0.009	0.002	-0.011	-0.024	0.22	0.05	-0.28	-0.62

Alignment measurement guidelines

Guideline	Explanation
Rotate the pump coupling half and the driver coupling half together so that the indicator rods have contact with the same points on the driver coupling half.	This prevents incorrect measurement.
Move or shim only the driver in order to make adjustments.	This prevents strain on the piping installations.
Make sure that the hold-down bolts for the driver feet are tight when you take indicator measurements.	This keeps the driver stationary since movement causes incorrect measurement.
Make sure that the hold-down bolts for the driver feet are loose before you make alignment corrections.	This makes it possible to move the driver when you make alignment corrections.
Check the alignment again after any mechanical adjustments.	This corrects any misalignments that an adjustment may have caused.

Attach the dial indicators for alignment

You must have two dial indicators in order to complete this procedure.

1. Attach two dial indicators on the pump coupling half (X):
 - a) Attach one indicator (P) so that the indicator rod comes into contact with the perimeter of the driver coupling half (Y).
This indicator is used to measure parallel misalignment.

- b) Attach the other indicator (A) so that the indicator rod comes into contact with the inner end of the driver coupling half. This indicator is used to measure angular misalignment.

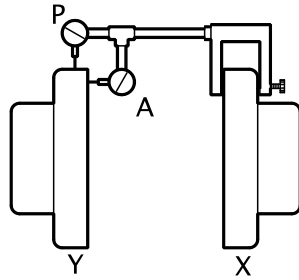

2. Rotate the pump coupling half (X) in order to check that the indicators are in contact with the driver coupling half (Y) but do not bottom out.
3. Adjust the indicators if necessary.

Perform angular alignment for a vertical correction

Illustrations are for reference only and may not depict the particular pump model.

1. Set the angular alignment indicator to zero at the top-center position (12 o'clock) of the driver coupling half (Y).
2. Rotate the indicator to the bottom-center position (6 o'clock).
3. Record the indicator reading.

When the reading value is...	Then...
Negative	The coupling halves are farther apart at the bottom than at the top. Perform one of these steps: <ul style="list-style-type: none"> • Add shims in order to raise the feet of the driver at the shaft end. • Remove shims in order to lower the feet of the driver at the other end.
Positive	The coupling halves are closer at the bottom than at the top. Perform one of these steps: <ul style="list-style-type: none"> • Remove shims in order to lower the feet of the driver at the shaft end. • Add shims in order to raise the feet of the driver at the other end.

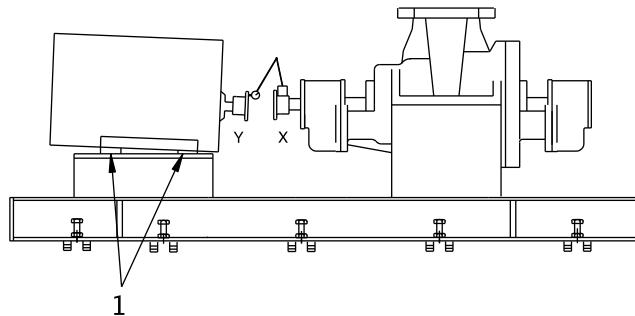

1. Shims

Figure 7: Example of incorrect vertical alignment (side view)

4. Repeat the previous steps until the permitted reading value is achieved.

Perform angular alignment for a horizontal correction

1. Set the angular alignment indicator (A) to zero on left side of the driver coupling half (Y), 90° from the top-center position (9 o'clock).

2. Rotate the indicator through the top-center position to the right side, 180° from the start position (3 o'clock).
3. Record the indicator reading.

When the reading value is...	Then...
Negative	The coupling halves are farther apart on the right side than the left. Perform one of these steps: <ul style="list-style-type: none"> • Slide the shaft end of the driver to the left. • Slide the opposite end to the right.
Positive	The coupling halves are closer together on the right side than the left. Perform one of these steps: <ul style="list-style-type: none"> • Slide the shaft end of the driver to the right. • Slide the opposite end to the left.

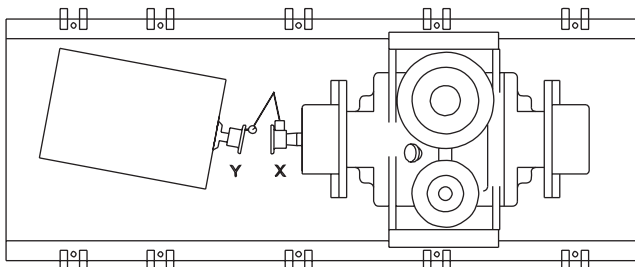

Figure 8: Example of incorrect horizontal alignment (top view)

4. Repeat the previous steps until the permitted reading value is achieved.

Perform parallel alignment for a vertical correction

Refer to the alignment table in "Permitted indicator values for alignment checks" (see Table of Contents for location of table) for the proper cold alignment value based on the motor temperature rise and the pump operating temperature.

Before you start this procedure, make sure that the dial indicators are correctly set up.

A unit is in parallel alignment when the parallel indicator (P) does not vary by more than 0.002 in. (0.05 mm) as measured at four points 90° apart at the operating temperature.

1. Set the parallel alignment indicator (P) to zero at the top-center position (12 o'clock) of the driver coupling half (Y).
2. Rotate the indicator to the bottom-center position (6 o'clock).
3. Record the indicator reading.

When the reading value is...	Then...
Negative	The pump coupling half (X) is lower than the driver coupling half (Y). Remove shims of a thickness equal to half of the indicator reading value under each driver foot.
Positive	The pump coupling half (X) is higher than the driver coupling half (Y). Add shims of a thickness equal to half of the indicator reading value to each driver foot.

NOTICE:

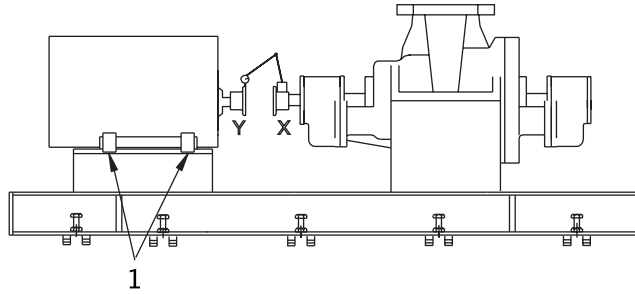

1. Shims

Figure 9: Example of incorrect vertical alignment (side view)

4. Repeat the previous steps until the permitted reading value is achieved.

Perform parallel alignment for a horizontal correction

A unit is in parallel alignment when the parallel indicator (P) does not vary by more than 0.002 in. (0.05 mm) as measured at four points 90° apart at the operating temperature.

1. Set the parallel alignment indicator (P) to zero on the left side of the driver coupling half (Y), 90° from the top-center position (9 o'clock).
2. Rotate the indicator through the top-center position to the right side, 180° from the start position (3 o'clock).
3. Record the indicator reading.

When the reading value is...	Then...
Negative	The driver coupling half (Y) is to the left of the pump coupling half (X).
Positive	The driver coupling half (Y) is to the right of the pump coupling half (X).

4. Slide the driver carefully in the appropriate direction.

NOTICE: Make sure to slide the driver evenly. Failure to do so can negatively affect horizontal angular correction.

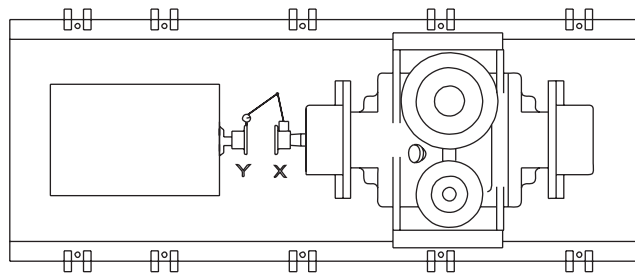

Figure 10: Example of incorrect horizontal alignment (top view)

5. Repeat the previous steps until the permitted reading value is achieved.

Perform complete alignment for a vertical correction

A unit is in complete alignment when both the angular indicator (A) and the parallel indicator (P) do not vary by more than 0.002 in. (0.05 mm) as measured at four points 90° apart.

1. Set the angular and parallel dial indicators to zero at the top-center position (12 o'clock) of the driver coupling half (Y).
2. Rotate the indicators to the bottom-center position (6 o'clock).
3. Record the indicator readings.
4. Make corrections according to the separate instructions for angular and parallel alignment until you obtain the permitted reading values.

Perform complete alignment for a horizontal correction

1. Set the angular and parallel dial indicators to zero at the left side of the driver coupling half (Y), 90° from the top-center position (9 o'clock).
2. Rotate the indicators through the top-center position to the right side, 180° from the start position (3 o'clock).
3. Record the indicator readings.
4. Make corrections according to the separate instructions for angular and parallel alignment until you obtain the permitted reading values.

Grout the baseplate

Required equipment:

- Cleaners: Do not use an oil-based cleaner because the grout will not bond to it. See the instructions provided by the grout manufacturer.
- Grout: Non-shrink grout is recommended.

NOTICE:

It is assumed that the installer who grouts the baseplate has knowledge of acceptable methods. More detailed procedures are described in various publications, including API Standard 610, latest edition, Appendix L; API RP 686, Chapter 5; and other industry standards.

1. Clean all the areas of the baseplate that will come into contact with the grout.
2. Build a dam around the foundation.
3. Thoroughly wet the foundation that will come into contact with the grout.
4. Pour grout through the grout hole into the baseplate up to the level of the dam.
When you pour the grout, remove air bubbles from it by using one of these methods:
 - Puddle with a vibrator.
 - Pump the grout into place.
5. Allow the grout to set.

Piping checklists

General piping checklist

Precautions



CAUTION:

- Never draw piping into place by using force at the flanged connections of the pump. This can impose dangerous strains on the unit and cause misalignment between the pump and driver. Pipe strain adversely affects the operation of the pump, which results in physical injury and damage to the equipment.
 - Vary the capacity with the regulating valve in the discharge line. Never throttle the flow from the suction side. This action can result in decreased performance, unexpected heat generation, and equipment damage.
-



CAUTION:

Flange loads from the piping system, including those from the thermal expansion of the piping, must not exceed the limits of the pump. Casing deformation can result in contact with rotating parts, which can result in excess heat generation, sparks, and premature failure.

Piping guidelines

Guidelines for piping are given in the Hydraulic Institute Standards available from the Hydraulic Institute at 9 Sylvan Way, Parsippany, NJ 07054-3802. You must review this document before you install the pump.

Checklist

Check	Explanation/comment	Checked
Check that all piping is supported independently of, and lined up naturally with, the pump flange. See Alignment criteria for pump flanges.	This helps to prevent: <ul style="list-style-type: none"> • Strain on the pump • Misalignment between the pump and the drive unit • Wear on the pump bearings, seal, and shafting 	
Check that only necessary fittings are used.	This helps to minimize friction losses.	
Do not connect the piping to the pump until: <ul style="list-style-type: none"> • The grout for the baseplate or sub-base becomes hard. • The hold-down bolts for the pump are tightened. 	—	
Make sure that all the piping joints and fittings are airtight.	This prevents air from entering the piping system or leaks that occur during operation.	
If the pump handles corrosive fluids, make sure that the piping allows you to flush out the liquid before you remove the pump.	The 3393 interstage casings cannot be completely drained. Use caution in disassembly.	
If the pump handles liquids at elevated temperatures, make sure that the expansion loops and joints are properly installed.	This helps to prevent misalignment due to thermal expansion of the piping.	

Alignment criteria for pump flanges

Type	Criteria
Axial	Flange face separation should be the gasket thickness ± 0.06 in. (1.5mm).
Parallel	For flanges with an outside diameter 10 in. (250mm) or less align the flanges to be parallel within 0.010 in. (0.25mm). Larger flanges should be parallel to 0.001 in./in. (0.001 mm/mm) up to a maximum allowable misalignment of 0.030 in. (0.75mm).
Concentric	You can easily install the flange bolts by hand.

Suction-piping checklist

Performance curve reference



CAUTION:

Vary the capacity with the regulating valve in the discharge line. Never throttle the flow from the suction side. This action can result in decreased performance, unexpected heat generation, and equipment damage.

Net positive suction head available ($NPSH_A$) must always exceed $NPSH_R$ as shown on the published performance curve of the pump.

Suction-piping checks

Check	Explanation/comment	Checked
Check that piping is free of dirt and foreign objects.	Dirt or debris can damage the pump on startup.	
Check that elbows in general do not have sharp bends.	This minimizes the risk of cavitation in the suction inlet of the pump due to turbulence.	

Check	Explanation/comment	Checked
Check that the suction piping is one or two sizes larger than the suction inlet of the pump. Install an eccentric reducer between the pump inlet and the suction piping.	The suction piping must never have a smaller diameter than the suction inlet of the pump.	
Check that the eccentric reducer at the suction flange of the pump has the following properties: <ul style="list-style-type: none"> • Sloping side down • Horizontal side at the top 	—	
If suction strainers or suction bells are used, check that they are at least three times the area of the suction piping.	Suction strainers help to prevent clogging. The strainer should be no coarser than 40 mesh – 60 mesh or higher is preferred. Strainers must have a minimum free open area of 300% of nominal pipe diameter. Velocities should be limited to 6-7 ft/s to keep the pressure drop across the strainer to a minimum.	
If more than one pump operates from the same liquid source, check that separate suction-piping lines are used for each pump.	This recommendation helps you to achieve a higher pump performance.	
If necessary, make sure that the suction piping includes a drain valve and that it is correctly installed.	—	

Liquid source below the pump

Check	Explanation/comment	Checked
Make sure that the suction piping is free from air pockets.	This helps to prevent the occurrence of air and cavitation in the pump inlet.	
Check that the suction piping slopes upwards from the liquid source to the pump inlet.	—	
	—	
If the pump is not self-priming, check that a device for priming the pump is installed.	Use a foot valve with a diameter that is at least equivalent to the diameter of the suction piping.	

Liquid source above the pump

Check	Explanation/comment	Checked
Check that an isolation valve is installed in the suction piping at a distance of at least two times the pipe diameter from the suction inlet.	This permits you to close the line during pump inspection and maintenance. Do not use the isolation valve to throttle the pump. Throttling can cause these problems: <ul style="list-style-type: none"> • Loss of priming • Excessive temperatures • Damage to the pump • Voiding the warranty 	
Make sure that the suction piping is free from air pockets.	This helps to prevent the occurrence of air and cavitation in the pump inlet.	
Check that the piping is level or slopes downward from the liquid source.	—	
Make sure that no part of the suction piping extends below the suction flange of the pump.	—	

Check	Explanation/comment	Checked
Make sure that the suction piping is adequately submerged below the surface of the liquid source.	This prevents air from entering the pump through a suction vortex.	

Discharge piping checklist

Checklist

Check	Explanation/comment	Checked
Check that an isolation valve is installed in the discharge line.	The isolation valve is required for: <ul style="list-style-type: none"> • Priming • Regulation of flow • Inspection and maintenance of the pump 	
Check that a check valve is installed in the discharge line, between the isolation valve and the pump discharge outlet.	The location between the isolation valve and the pump allows inspection of the check valve. The check valve prevents damage to the pump and seal due to the back flow through the pump, when the drive unit is shut off. It is also used to restrain the liquid flow.	
If increasers are used, check that they are installed between the pump and the check valve.	—	
If quick-closing valves are installed in the system, check that cushioning devices are used.	This protects the pump from surges and water hammer.	

Auxiliary-piping checklist

Precautions



WARNING:

- Cooling systems such as those for bearing lubrication and mechanical-seal systems must be operating properly to prevent excess heat generation, sparks, and premature failure.
- Sealing systems that are not self-purging or self-venting, such as plan 23, require manual venting prior to operation. Failure to do so will result in excess heat generation and seal failure.

NOTICE:

The mechanical seal must have an appropriate seal-flush system. Otherwise, excess heat generation and seal failure can occur.

When to install

You may need to install auxiliary piping for mechanical seal flush or other special features supplied with the pump. Consult the pump data sheet for specific auxiliary piping recommendations.

Checklist

Check	Explanation/comment	Checked
Check that cooling flows and pressures are in accordance with heat exchanger manufacturer recommendations.	—	
Check that the cooling water pressure does not exceed 100 psig (7.0 kg/cm ²).	—	

Final piping checklist

Check	Explanation/comment	Checked
Check that the shaft rotates smoothly.	Rotate the shaft by hand. Make sure there is no rubbing that can lead to excess heat generation or sparks.	
Re-check the alignment to make sure that pipe strain has not caused any misalignment.	If pipe strain exists, then correct the piping.	

Commissioning, Startup, Operation, and Shutdown

Preparation for startup

 When installing in a potentially explosive environment, ensure that the motor is properly certified.



DANGER:
Avoid death or serious injury. Explosion and/or seizure of pump can cause fire and/or burns. Never operate pump past the pressure and temperature limits shown on the nameplate on the pump.



WARNING:

- Failure to follow these precautions before you start the unit will lead to serious personal injury and equipment failure.
- When installing in a potentially explosive environment, make sure that the motor is properly certified and that all equipment is installed in accordance with instructions for that environment.
- Do not operate the pump dry.
- Do not operate the pump below the hydraulic or thermal minimum rated flows or with the suction or discharge valves closed. These conditions can create an explosive hazard due to vaporization of pumped fluid and can quickly lead to pump failure and physical injury.
- Avoid death or serious injury. Leaking fluid can cause fire and/or burns. Operating the pump above maximum rated flow shown on the pump curve leading to an increase in horsepower and vibration along with an increase in NPSHr resulting in mechanical seal and/or shaft failure and/or loss of prime.
- Avoid death or serious injury. Leaking fluid can cause fire and/or burns. Speed of pump must reach 2700 rpm within 5 seconds or an increase in vibration and rotor deflection and decrease in rotor stability leading to mechanical seal and/or shaft failure and/or pump seizure can occur.
- Always disconnect and lock out power to the driver before you perform any installation or maintenance tasks. Failure to disconnect and lock out driver power will result in serious physical injury.
- Operating the pump in reverse rotation can result in the contact of metal parts, heat generation, and breach of containment.
- Service temperature in an ATEX classified environment is limited to the area classification specified on the ATEX tag affixed to the pump (reference Table 1 in the Safety Section for ATEX classifications).
- Avoid death or serious injury. Explosion and/or seizure of pump can cause fire and/or burns. Assure balance line is installed and either piped to the pump suction or back to the suction vessel to avoid vaporization of pumped fluid.



DANGER:
Avoid death or serious injury. Leaking fluid can cause fire and/or burns. Assure all openings are sealed off prior to filling pump.

Precautions

NOTICE:

- Verify the driver settings before you start any pump.
- Make sure that the temperature change does not exceed 35°F (19°C) per minute.
- The maximum allowable temperature change for an abnormal transient event such as thermal shock is 400°F (205°C).

You must follow these precautions before you start the pump:

- Flush and clean the system thoroughly to remove dirt or debris in the pipe system in order to prevent premature failure at initial startup.
- Bring variable-speed drivers to the rated speed within 5 seconds.
- If temperatures of the pumped fluid will exceed 200°F (93°C), then warm up the pump prior to operation. Circulate a small amount of fluid through the pump until the casing temperature is within 100°F (38°C) of the fluid temperature.

At initial startup, do not adjust the variable-speed drivers or check for speed governor or over-speed trip settings while the variable-speed driver is coupled to the pump. If the settings have not been verified, then uncouple the unit and refer to instructions supplied by the driver manufacturer.

Variable Speed Operation

If the 3393 is to be run with a variable speed drive, please confirm that the application has been approved by the factory. Variable speed operation is limited to 2700 to 3600 rpm unless a lateral critical speed analysis has been conducted by the factory and the speed range has been approved for operation. In all cases it is imperative that the pump be brought up to its minimum operating speed as quickly as possible. This ramp up time should not exceed 5 seconds.

Remove the coupling guard

1. Remove the nut, bolt, and washers from the slotted hole in the center of the coupling guard.
2. Slide the driver half of the coupling guard toward the pump.
3. Remove the nut, bolt, and washers from the driver half of the coupling guard.
4. Remove the driver-side end plate.
5. Remove the driver half of the coupling guard:
 - a) Slightly spread the bottom apart.
 - b) Lift upwards.
6. Remove the remaining nut, bolt, and washers from the pump half of the coupling guard. It is not necessary to remove the end plate from the pump side of the bearing housing. You can access the bearing-housing tap bolts without removing this end plate if maintenance of internal pump parts is necessary.
7. Remove the pump half of the coupling guard:
 - a) Slightly spread the bottom apart.
 - b) Lift upwards.

Check the rotation



WARNING:

- Operating the pump in reverse rotation can result in the contact of metal parts, heat generation, and breach of containment.
- Always disconnect and lock out power to the driver before you perform any installation or maintenance tasks. Failure to disconnect and lock out driver power will result in serious physical injury.

1. Lock out power to the driver.
2. Make sure that the coupling hubs are fastened securely to the shafts.
3. Make sure that the coupling spacer is removed.
The pump ships with the coupling spacer removed.
4. Unlock power to the driver.
5. Make sure that everyone is clear, and then jog the driver long enough to determine that the direction of rotation corresponds to the arrow on the bearing housing or close-coupled frame.
6. Lock out power to the driver.

Couple the pump and driver



⚠ When installing in a potentially explosive environment, ensure that the motor is properly certified.

WARNING:

- Always disconnect and lock out power to the driver before you perform any installation or maintenance tasks. Failure to disconnect and lock out driver power will result in serious physical injury.
- The coupling used in an ATEX or Ex-classified environment must be properly certified and must be constructed from a non-sparking material.

1. Check the gap between the coupling hubs against the dimensions shown on the elevation drawing or as stamped on the coupling hub. For any necessary adjustment, move the driver not the pump.

Motors with sleeve bearings may be manufactured with 1/4 or 1/2 in. (6.35 or 12.7 mm) end movement (float) in the motor rotor. For limited end-float arrangement, the gap between the coupling halves must be set in a different manner. If specific directions are not indicated in the motor instructions, then follow this procedure:

NOTICE:

If the driver was mounted at the factory, the setting for the coupling is already determined.

- a) Slide the rotor towards the outboard end of the motor as far as it will go and mark the shaft at the motor frame.
- b) Slide the rotor towards the inboard end of the motor as far as it will go and mark the shaft again.
The distance between the marks should be either 1/2 or 1/4 in. (6.35 or 12.7 mm) if the motor is arranged for limited end-float travel.
- c) Scribe a third mark on the shaft halfway between the scribe marks made in the previous steps.
- d) Clamp the rotor in place.

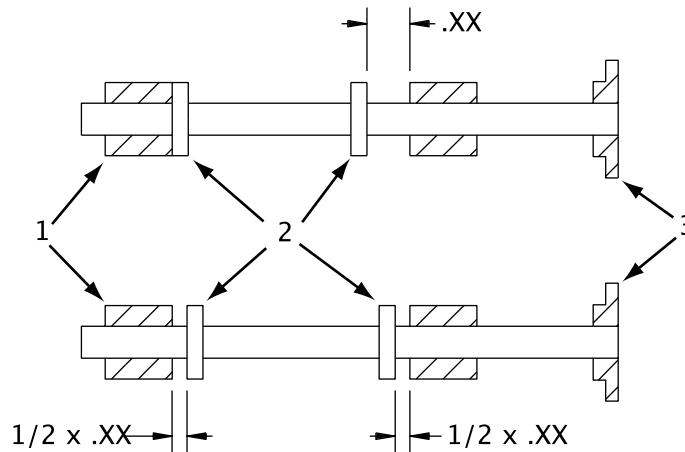

1. Sleeve bearing
2. Thrust collar
3. Coupling

2. Use the instructions from the coupling manufacturer to lubricate and install the coupling.
3. Check the angular and parallel alignment of the coupling halves. See Pump-to-driver alignment in the Installation chapter.

Coupling guard assembly

 The coupling guard used in an ATEX classified environment must be constructed from a non-sparking material.

Precautions



WARNING:

- Never operate a pump without a properly installed coupling guard. Personal injury will occur if you run the pump without a coupling guard.
- Avoid death or serious injury. Assure mechanical seal guard is properly installed using supplied fastening hardware.
- Always disconnect and lock out power to the driver before you perform any installation or maintenance tasks. Failure to disconnect and lock out driver power will result in serious physical injury.

Required parts

These parts are required:

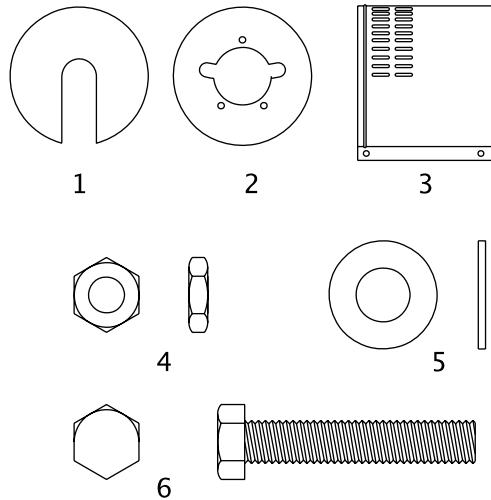

1. End plate, drive end
2. End plate, pump end
3. Guard half, 2 required
4. 3/8-16 nut, 3 required
5. 3/8 in. washer
6. 3/8-16 x 2 in. hex head bolt, 3 required

Install the coupling guard

1. De-energize the motor, place the motor in a locked-out position, and place a caution tag at the starter that indicates the disconnect.
2. Put the pump-half of the coupling guard in place:
 - a) Slightly spread the bottom apart.

b) Place the coupling guard half over the pump-side end plate.

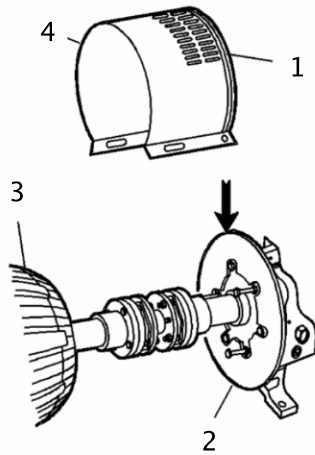

1. Annular groove
2. Pump-side end plate
3. Driver
4. Pump half of the coupling guard

The annular groove in the coupling guard half must fit around the end plate.

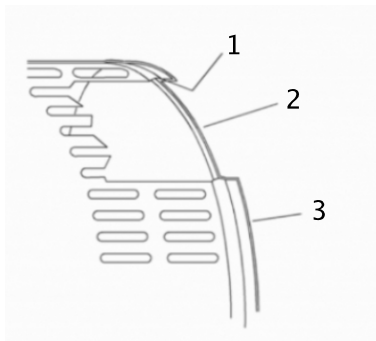

1. Annular groove
 2. End plate (pump end)
 3. Guard half
3. Use a bolt, a nut, and two washers to secure the coupling guard half to the end plate. Tighten securely.

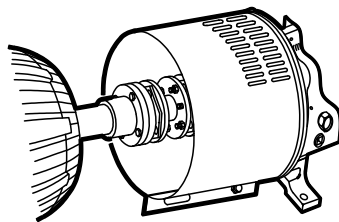

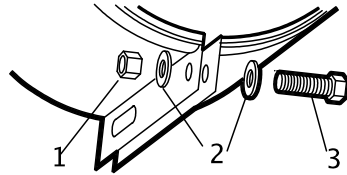

1. Nut
 2. Washer
 3. Bolt
4. Put the driver half of the coupling guard in place:
 - a) Slightly spread the bottom apart.
 - b) Place the driver half of the coupling guard over the pump half of the coupling guard. The annular groove in the coupling guard half must face the motor.
 5. Place the driver-side end plate over the motor shaft.
 6. Place the driver-side end plate in the annular groove of the driver-half of the coupling guard.
 7. Use a bolt, a nut, and two washers to secure the coupling guard half to the end plate. Hand-tighten only. The hole is located on the driver-side of the coupling guard half.
 8. Slide the driver-half of the coupling guard towards the motor so that the coupling guard completely covers the shafts and coupling.
 9. Use a nut, a bolt, and two washers to secure the coupling guard halves together.
 10. Tighten all nuts on the guard assembly.



WARNING:
Never operate the pump without the coupling guard correctly installed.

Bearing lubrication

 Bearings must be lubricated properly in order to prevent excess heat generation, sparks and premature failure.

Precautions



WARNING:
Make sure to properly lubricate the bearings. Failure to do so can result in excess heat generation, sparks, and premature failure.

NOTICE:
Avoid equipment damage. Refer to driver/coupling/gear manufactures IOM for instructions and recommendations for lubrication.

Pumps are shipped without oil

You must lubricate oil-lubricated bearings at the job site.

Flood oil lubrication

Flood oil-lubricated bearings are standard. Bearing housings are supplied with constant-level oilers and sight glasses. If the oiler can be accessed easily from either side of the bearing frame, the recommendation is to install it on the side of the bearing frame that the rotation of the shaft would push the oil toward. That is if, when facing the shaft, the rotation is clockwise the oiler would be on the left and when counter clockwise the oiler would be on the right.

However, the oiler can be installed on either side of the bearing housing so it should be put where it is most easily accessible.

Oil volumes

This table shows the required amount of oil for oil-lubricated bearings.

Lubricating oil requirements

Quality requirements

Use a high quality turbine oil with rust and oxidation inhibitors.

See Lubricating Oil Requirements in "Maintenance of Bearings" for common names of some acceptable lubricating oils.

3393 Ball Bearings				
Pump size	2.5x4-8 2.5x5-8	4x5-10 4x6-10	5x6-11 5x8-11	6x8-13 6x10-13
Initial Fill per Bearing Housing - Oil (US pt, l)	3.4 / 1.6	3.4 / 1.6	5.3 / 2.5	5.3 / 2.5
Bearing - Driver End	7408	7409	7311	7214
Bearing - Outboard (ES) ¹	SiC/SiC	SiC/SiC	SiC/SiC	SiC/SiC
Bearing - Outboard (RS)	6408	6409	6311	6214
Maximum permissible surface temperature measured at the 12 o'clock (top of bearing housing) position. (°F, °C)	180 / 82	180 / 82	180 / 82	180 / 82

Lubricate the bearings with oil

Flood oil-lubricated pumps are supplied with an oiler that maintains a constant oil level in the bearing housing.

1. Fill the oil reservoir in the bearing frame:
 - a) Fill the bearing chamber through the main body of the Watchdog until it reaches the optimum fluid level visible in the bullseye sight.
 - b) Fill the watchdog reservoir using a funnel.
 - c) Verify o-ring is on the Watchdog oiler spout.
 - d) Place your thumb over the reservoir spout. Invert and insert the spout into the internal threaded boss on the main body.
 - e) Tighten reservoir. Do not over-tighten.
 - f) Verify that proper oil level is maintained per the following diagram.

NOTICE:

Do not fill the oil reservoir of the bearing frame through the plug at the top.

¹ Product lubricated bearing

2. Check that the oil level is correct. The correct oil level is centered in the bullseye sight glass, when the pump is not in operation. During operation, bullseye sight gives a false oil level reading.

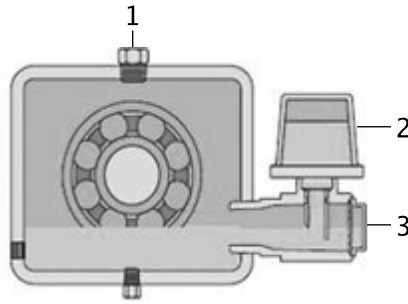

1. Plug
2. Reservoir
3. Main body

Purge Oil Mist

The 3393 can be modified for purge oil mist lubrication. Consult a factory representative for details.

Lubricate the bearings after a shutdown period

1. Flush out the bearings and bearing frame with a light oil to remove contaminants. During flushing, make sure to rotate the shaft slowly by hand.
2. Flush the bearing housing with the proper lubricating oil to ensure oil quality after cleaning.

Shaft sealing with a mechanical seal

 The mechanical seal used in an ATEX classified environment must be properly certified.

Precautions



WARNING:

The mechanical seal used in an ATEX or Ex-classified environment must be properly certified. Prior to startup, make sure that all areas that could leak pumped fluid to the work environment are closed.

NOTICE:

- The mechanical seal must have an appropriate seal-flush system. Otherwise, excess heat generation and seal failure can occur.
- Cooling systems such as those for bearing lubrication and mechanical-seal systems must be operating properly to prevent excess heat generation, sparks, and premature failure.
- Sealing systems that are not self-purging or self-venting, such as plan 23, require manual venting prior to operation. Failure to do so will result in excess heat generation and seal failure.

Shipping

Pumps may be shipped with or without a mechanical seal installed.

Cartridge-type mechanical seals

Cartridge-type mechanical seals are commonly used. Cartridge seals are preset by the seal manufacturer and require no field settings. Cartridge seals installed by the user require disengagement of the holding clips prior to operation, allowing the seal to slide into place. If the seal has been installed in the pump by ITT, these clips have already been disengaged.

Connection of sealing liquid for mechanical seals

 The mechanical seal must have an appropriate seal flush system. Failure to do so will result in excess heat generation and seal failure.

Seal lubrication is required

Mechanical seals must have an appropriate seal flush system to avoid excessive heat generation and premature seal failure.

Seal faces must have liquid film between them for proper lubrication. Locate the taps using the illustrations shipped with the seal.

Seal flushing methods

You can use these methods in order to flush or cool the seal:

Method	Description
Product flush	Run the piping so that the pump pushes the pumped fluid from the casing and injects it into the seal gland. If necessary, an external heat exchanger cools the pumped fluid before it enters the seal gland.
External flush	Run the piping so that the pump injects a clean, cool, compatible liquid directly into the seal gland. The pressure of the flushing liquid must be 5 to 15 psi (0.35 to 1.01 kg/cm ²) greater than the seal chamber pressure. The injection rate must be 0.5 to 2 gpm (2 to 8 lpm).
Other	You can use other methods that employ multiple gland or seal chamber connections. Refer to the mechanical seal reference drawing and piping diagrams.

Prime the pump with the suction supply above the pump

 Pumps that are not self-priming must be fully primed at all times during operation.

1. Slowly open the suction isolation valve.
2. Open the air vents on the suction and discharge piping, the casing, the seal chamber, and the seal piping, if provided, until all air is vented and only the pumped fluid flows out.
3. Close the air vents.

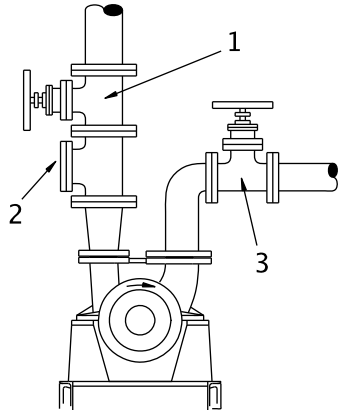

1. Discharge isolation valve
2. Check valve
3. Suction isolation valve

Start the pump



WARNING: Immediately observe the pressure gauges. If discharge pressure is not quickly attained, stop the driver immediately, reprime, and attempt to restart the pump.

**CAUTION:**

- Observe the pump for vibration levels, bearing temperature, and excessive noise. If normal levels are exceeded, shut down the pump and resolve the issue.

Before you start the pump, you must perform these tasks:

- Open the suction valve.
 - Open any recirculation or cooling lines.
1. Fully close or partially open the discharge valve, depending on system conditions.
 2. Start the driver.
If the pump is to be run with a variable speed device, it should be brought up to 2700 rpm within 5 seconds. If a lateral critical speed analysis has been done, it must be brought up to the minimum allowable operating speed within 5 seconds.
 3. Slowly open the discharge valve until the pump reaches the desired flow.
 4. Immediately check the pressure gauge to ensure that the pump quickly reaches the correct discharge pressure.
 5. If the pump fails to reach the correct pressure, perform these steps:
 - a) Stop the driver.
 - b) Prime the pump again.
 - c) Restart the driver.
 6. Monitor the pump while it is operating:
 - a) Check the pump for bearing temperature, excessive vibration, and noise.
 - b) If the pump exceeds normal levels, then shut down the pump immediately and correct the problem.
 7. Repeat steps 5 and 6 until the pump runs properly.

Activate the i-ALERT Condition Monitor

**WARNING:**

Never heat the condition monitor to temperatures in excess of 300°F (149°C). Heating to these temperatures could result in death or serious injury.

**CAUTION:**

Always wear protective gloves. The pump and condition monitor can be hot.

NOTICE:

Do not use the condition monitor in atmospheres containing acetic acid.

By using the i-Alert™ Condition monitor, you agree to be bound by the Terms and Conditions of the [Software License Agreement](#) (page 15)

The condition monitor is ready for activation when the pump is running and has reached a steady flow, pressure, and temperature. This process only takes a few minutes.

1. Place a small magnet on the condition monitor over the ITT logo and then remove it, as this example shows.

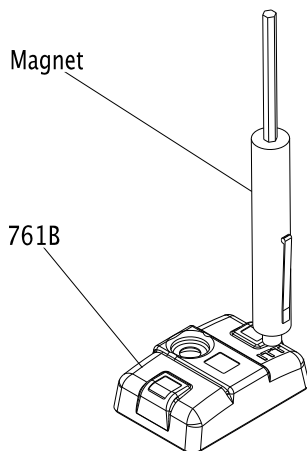

When the condition monitor is activated it:

1. Displays a series of red LEDs followed by a solid green LED.
2. Collects eight samples that are spaced one second apart.
3. Averages these readings to establish the baseline vibration level.
4. Flashes a green LED after approximately twelve seconds.

For the first ten minutes, the green LED flashes every second for five consecutive flashes and then pauses to take a vibration reading. More frequent measurements (every six seconds) are taken in this startup period so that an alarm can be immediately detected.

i-ALERT™ Condition Monitor routine operation

Measurement interval

This table shows the measurement intervals for the condition monitor during normal operation and when the monitor is in alarm mode.

Mode	Measurement interval
Normal operating mode	Five minutes
Alarm mode	Two minutes

When the condition monitor measures a reading beyond the specified temperature and vibration limits, the appropriate red LED flashes. After the process or pump condition that causes the alarm is corrected, the condition monitor returns to normal mode after one normal-level measurement.

Alarm mode

When the condition monitor is in alarm mode, you should investigate the cause of the condition and make necessary corrections in a timely manner.

Magnetic device considerations

Be careful when you use magnetic devices in close proximity of the condition monitor, such as magnetic vibration-monitoring probes or dial indicators. These magnetic devices can accidentally activate or deactivate the condition monitor resulting in improper alarm levels or loss of monitoring.

Pump operation precautions

General considerations



CAUTION:

- Vary the capacity with the regulating valve in the discharge line. Never throttle the flow from the suction side since this can result in decreased performance, unexpected heat generation, and equipment damage.
 - Do not overload the driver. Driver overload can result in unexpected heat generation and equipment damage. The driver can overload in these circumstances:
 - The specific gravity of the pumped fluid is greater than expected.
 - The pumped fluid exceeds the rated flow rate.
 - Make sure to operate the pump at or near the rated conditions. Failure to do so can result in pump damage from cavitation or recirculation.
-

NOTICE:

- Make sure the oil level has remained steady by checking the oiler.
 - Check the bearing temperatures using a pyrometer or other temperature-measuring device. Monitor the bearing temperature frequently during initial operation in order to determine if a bearing problem exists, as well as to establish normal bearing operating temperature.
 - For pumps with auxiliary piping, make sure that proper flows have been established and that the equipment is operating properly.
 - Establish baseline vibration readings in order to determine normal running conditions. If the unit is running roughly, then consult the factory.
 - Monitor all gauges to ensure that the pump is running at or near rating and that the suction screen (when used) is not clogged.
-

Operation at reduced capacity



WARNING:

Never operate any pumping system with a blocked suction and discharge. Operation, even for a brief period under these conditions, can cause confined pumped fluid to overheat, which results in a violent explosion. You must take all necessary measures to avoid this condition. If pump becomes plugged shut down and unplug prior to restarting pump.



CAUTION:

- Avoid excessive vibration levels. Excessive vibration levels can damage the bearings, stuffing box or seal chamber, and the mechanical seal, which can result in decreased performance.
 - Avoid increased radial load. Failure to do so can cause stress on the shaft and bearings.
 - Avoid heat build-up. Failure to do so can cause rotating parts to score or seize.
 - Avoid cavitation. Failure to do so can cause damage to the internal surfaces of the pump.
-

Operation under freezing conditions

NOTICE:

Shut down the pump



WARNING:

The pump can handle hazardous and toxic fluids. Identify the contents of the pump and observe proper decontamination procedures in order to eliminate the possible exposure to any hazardous or toxic fluids. Wear the proper personal protective equipment. Potential hazards include, but are not limited to, high temperature, flammable, acidic, caustic, explosive, and other risks. You must handle and dispose of pumped fluid in compliance with the applicable environmental regulations.

1. Slowly close the discharge valve.
2. Shut down and lock the driver to prevent accidental rotation.
3. Bring the pump to a complete stop within 5 seconds.

Deactivate the i-ALERT™ Condition Monitor

NOTICE:

Always deactivate the condition monitor when the pump is going to be shut down for an extended period of time. Failure to do so will result in reduced battery life.

1. Touch and hold a small magnet to the condition monitor over the ITT logo until the red LEDs blink three times.
This should take 10-15 seconds if the condition monitor is in normal operating mode and approximately five seconds if the condition monitor is in alarm mode.
2. Remove the magnet.

If the deactivation is successful, solid red LEDs will be displayed.

Reset the i-ALERT™ Condition Monitor

NOTICE:

Always reset the condition monitor when the pump is started after maintenance, system change, or down-time. Failure to do so may result in false baseline levels that could cause the condition monitor to alert in error.

1. Touch a magnet to the condition monitor over the ITT logo to turn the power on. The condition monitor begins to establish a new baseline vibration level.

Make the final alignment of the pump and driver



 Alignment procedures must be followed to prevent unintended contact of rotating parts. Follow coupling manufacturer's installation and operation procedures.

WARNING:

- Always disconnect and lock out power to the driver before you perform any installation or maintenance tasks. Failure to disconnect and lock out driver power will result in serious physical injury.
 - Follow shaft alignment procedures in order to prevent catastrophic failure of drive components or unintended contact of rotating parts. Follow the coupling installation and operation procedures from the coupling manufacturer.
-

You must check the final alignment after the pump and driver are at operating temperature. For initial alignment instructions, see the Installation chapter.

1. Run the unit under actual operating conditions for enough time to bring the pump, driver, and associated system to operating temperature.
2. Shut down the pump and the driver.

3. Lock out power to the driver.
4. Remove the coupling guard.
See Remove the coupling guard in the Maintenance chapter.
5. Check the alignment while the unit is still hot.
See Pump-to-driver alignment in the Installation chapter.
6. Reinstall the coupling guard.
7. Restart the pump and driver.

Maintenance

Maintenance precautions



WARNING:

- This manual clearly identifies accepted methods for disassembling units. These methods must be adhered to. Trapped liquid can rapidly expand and result in a violent explosion and injury. Never apply heat to impellers, propellers, or their retaining devices to aid in their removal unless explicitly stated in this manual.
 - Always disconnect and lock out power to the driver before you perform any installation or maintenance tasks. Failure to disconnect and lock out driver power will result in serious physical injury.
 - Crush hazard. The unit and the components can be heavy. Use proper lifting methods and wear steel-toed shoes at all times.
 - The pump can handle hazardous and toxic fluids. Identify the contents of the pump and observe proper decontamination procedures in order to eliminate the possible exposure to any hazardous or toxic fluids. Wear the proper personal protective equipment. Potential hazards include, but are not limited to, high temperature, flammable, acidic, caustic, explosive, and other risks. You must handle and dispose of pumped fluid in compliance with the applicable environmental regulations.
-

Maintenance schedule

 The preventive maintenance section must be adhered to in order to keep the applicable ATEX classification of the equipment. Failure to follow these procedures will void the ATEX classification for the equipment.

Maintenance inspections

A maintenance schedule includes these types of inspections:

- Routine maintenance
- Routine inspections
- Three-month inspections
- Annual inspections

Shorten the inspection intervals appropriately if the pumped fluid is abrasive or corrosive or if the environment is classified as potentially explosive.

Routine maintenance

Perform these tasks whenever you perform routine maintenance:

- Lubricate the bearings.
- Inspect the seal.

Routine inspections

Perform these tasks whenever you check the pump during routine inspections:

- Check for unusual noise, vibration, and bearing temperatures.
- Check the pump and piping for leaks.
- Analyze the vibration.
- Check the seal chamber and stuffing box for leaks.
 - Ensure that there are no leaks from the mechanical seal.
 - Adjust or replace the packing in the stuffing box if you notice excessive leaking.
- Check that there is no leakage from the mechanical seal.

Three-month inspections

Perform these tasks every three months:

- Check that the foundation and the hold-down bolts are tight.
- Check the shaft alignment, and realign as required.

Annual inspections

Perform these inspections one time each year:

- Check the pump capacity.
- Check the pump pressure.
- Check the pump power.

If the pump performance does not satisfy your process requirements, and the process requirements have not changed, then perform these steps:

1. Disassemble the pump.
2. Inspect it.
3. Replace worn parts.

Bearing maintenance

Bearing replacement

- The end suction arrangement uses a silicon carbide sleeve bearing which is retained in a holder integral with the end suction casing.
- The radial suction arrangement uses a bearing housing identical to the bearing housing on the discharge side but with a single row ball bearing for radial loads.
- The discharge side bearing housing has back to back angular contact thrust bearings and the 5" (125mm) discharge size and larger has a cooling fan mounted on the pump shaft.
- Clean and check condition of all parts that have been removed. When in doubt, components should be replaced. Wearing parts (ball bearings) and seals must always be replaced.
- If parts or half-open pumps are to be stored for any length of time, they must be protected from dirt and corrosion.

Maintenance of Bearings

OIL LUBRICATED BEARINGS



WARNING:

Make sure that the unit cannot roll or fall over and injure people or damage property.

After the pump has been installed, flush the housing to remove dirt, grit, and other impurities that may have entered the bearing housing during shipment or installation; then refill the housing with proper lubricant.

Note: Do not fill the oil reservoir of the bearing frame through the vent or through the oiler housing without using the oiler bottle. The oil level will be maintained by the Trico oiler.

Acceptable Lubricants

The table below lists some commonly available oils that meet this specification.

Brand	Lubricant Type
Chevron	GST Oil 68
Exxon Mobile	Teresstic EP 68
	DTE 26 300 SSU @ 100°F (38°C)
Shell	Tellus Oil 68
Sunoco	Sunvis 968
Royal Purple	SYNFILM ISO VG 68 Synthetic lube

3393 Ball Bearings				
Pump size	2.5x4-8 2.5x5-8	4x5-10 4x6-10	5x6-11 5x8-11	6x8-13 5x10-13
Initial Fill per Bearing Housing - Oil (US pt, l)	3.4 / 1.6	3.4 / 1.6	5.3 / 2.5	5.3 / 2.5
Bearing - Driver End	7408	7409	7311	7214
Bearing - Outboard (ES) ²	SiC/SiC	SiC/SiC	SiC/SiC	SiC/SiC
Bearing - Outboard (RS)	6408	6409	6311	6214
Maximum permissible surface temperature measured at the 12 o'clock (top of bearing housing) position (°F, °C)	180 / 82	180 / 82	180 / 82	180 / 82

Mechanical-seal maintenance



WARNING:

The mechanical seal used in an ATEX or Ex-classified environment must be properly certified. Prior to startup, make sure that all areas that could leak pumped fluid to the work environment are closed.



CAUTION:

Never operate the pump without liquid supplied to mechanical seal. If you run a mechanical seal dry, even for a few seconds, this can cause seal damage. Physical injury can occur if a mechanical seal fails.

Cartridge-type mechanical seals

Cartridge-type mechanical seals are commonly used. Cartridge seals are preset by the seal manufacturer and require no field settings. Cartridge seals installed by the user require disengagement of the holding clips prior to operation, allowing the seal to slide into place. If the seal has been installed in the pump by ITT, these clips have already been disengaged.

Other mechanical seal types

For other types of mechanical seals, refer to the instructions provided by the seal manufacturer for installation and setting.

Before you start the pump

Check the seal and all flush piping.

Disassembly

Introduction

The section on disassembly will address the bearings, mechanical seal, balance drum and balance drum stator as well as the complete pump. Where the disassembly is the same for end and radial suction pumps, no distinction will be made. When the disassembly is different, it will be identified for either end or radial suction configuration.

² Product lubricated bearing

Disassembly precautions



WARNING:

- This manual clearly identifies accepted methods for disassembling units. These methods must be adhered to. Trapped liquid can rapidly expand and result in a violent explosion and injury. Never apply heat to impellers, propellers, or their retaining devices to aid in their removal unless explicitly stated in this manual.
- Always disconnect and lock out power to the driver before you perform any installation or maintenance tasks. Failure to disconnect and lock out driver power will result in serious physical injury.
- Crush hazard. The unit and the components can be heavy. Use proper lifting methods and wear steel-toed shoes at all times.
- The pump can handle hazardous and toxic fluids. Identify the contents of the pump and observe proper decontamination procedures in order to eliminate the possible exposure to any hazardous or toxic fluids. Wear the proper personal protective equipment. Potential hazards include, but are not limited to, high temperature, flammable, acidic, caustic, explosive, and other risks. You must handle and dispose of pumped fluid in compliance with the applicable environmental regulations.
- A small amount of liquid will be present in certain areas like the seal chamber.

NOTICE:

- Avoid injury. Worn pump components can have sharp edges. Wear appropriate gloves while handling these parts.
- Always wear the proper Personal Protective Equipment (PPE).
- Make sure that all replacement parts are available before you disassemble the pump for overhaul.
- Make sure that no damage occurs to any part during disassembly that will impede the removal of other parts. For example, damage to the shaft that makes it difficult to remove a part that must slide over that part of the shaft.

Required Tools

Metric Wrenches (Hex and Open Ended)	Torque Wrench with Metric Socket
Screwdriver	Dial Indicator
Lifting Slings	Metric Micrometers (Inside and Outside)
Soft Faced Hammer	Cleaning Agents and Solvents
Induction Bearing Heater	Feeler Gauges
Brass Drift Punch	Metric Allen Wrenches
Brass Drift Punch	Files
Spanner Wrench	Emery Cloth

Disassembly



WARNING:

Make sure that the unit cannot roll or fall over and injure people or damage property.

1. Shut off all valves controlling flow to and from pump.
2. Drain liquid from piping. Flush pump if necessary.
3. Lock out power to the driver.
4. Disconnect all auxiliary piping and tubing.
5. Remove coupling guard.
6. Disconnect coupling.
7. Unbolt the pump from the piping system and baseplate and remove pump from baseplate.
8. Drain oil from the bearing housing(s) before inverting the pump.

Disassembly of suction end bearing

End suction pump - item 117 (sleeve bearing)

See relevant sectional drawing

NOTICE: It is not recommended to remove the product lube bearing (197A) unless it is worn or damaged.

NOTICE: Replacement of this bearing requires removal of the pump from the pipework and baseplate.

1. Unbolt the pump from the piping system and baseplate.
2. Support the pump vertically with the suction casing uppermost.
3. Remove the balance line and any seal flush piping.
4. Remove the tie rod nuts (357F) and tie rod washers (437A) on the suction end of pump.
5. Remove suction casing (100S). Bearing 197A will be in the suction casing. Remove the o-ring (412K).
6. Remove capscrew (469Y) and retaining plate (467).
7. Remove sleeve bearing (117) and tolerance rings (505D) from the end of the shaft.
8. Inspect the bearing sleeve for damage and check the clearance between the sleeve bearing and the stationary bearing.
9. Unless the stationary bearing (197A) is worn or damaged it should not be removed from the suction casing.
10. If necessary, remove stationary bearing (197A) from the suction casing being careful to avoid damage to the casing..

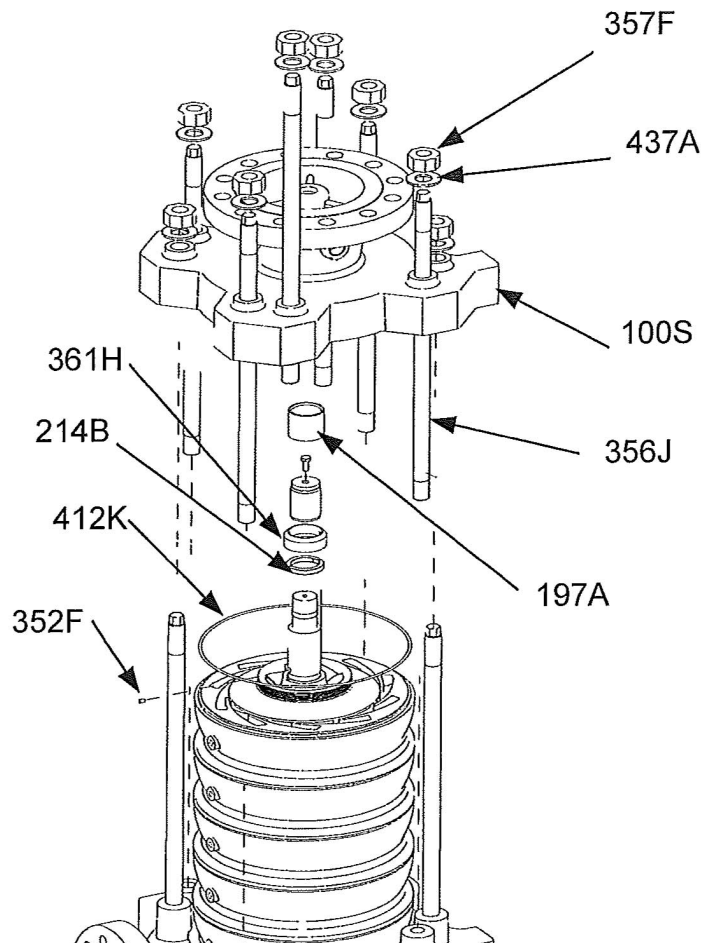

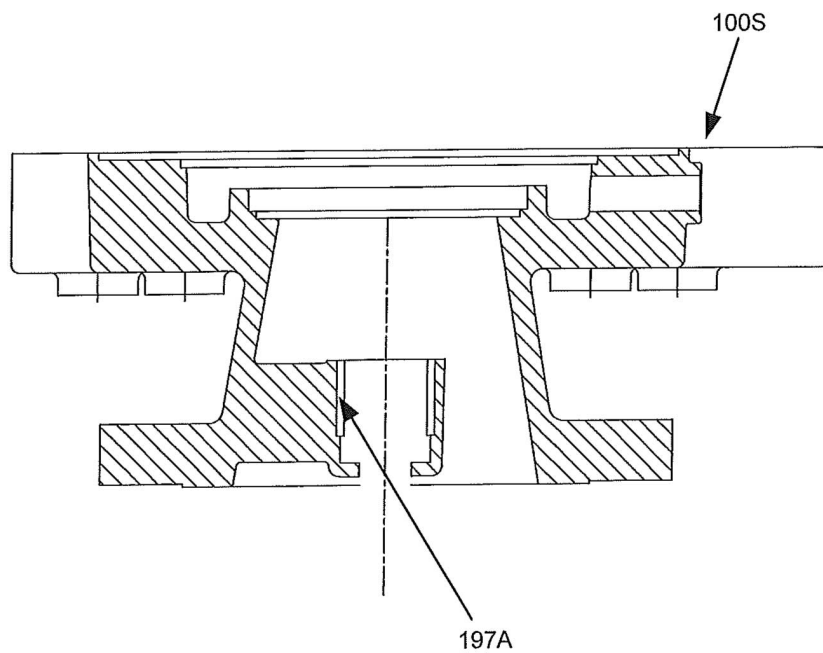
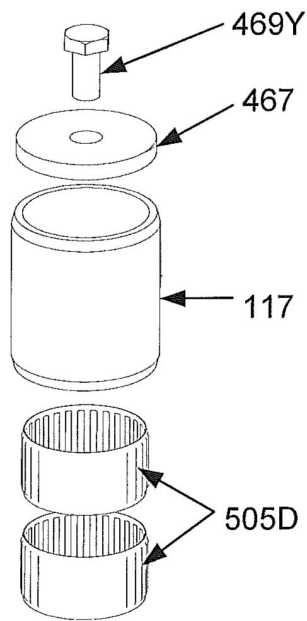
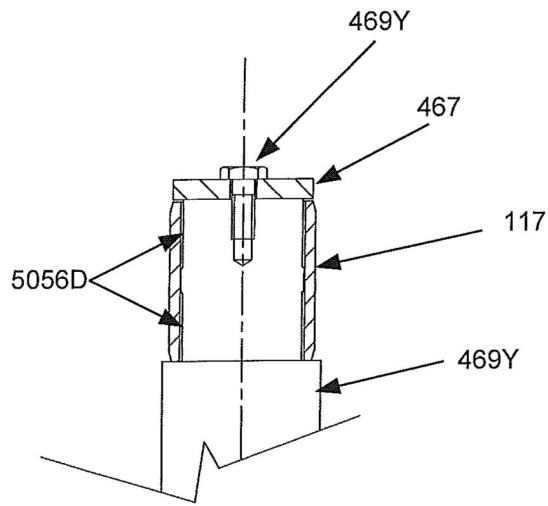

Radial suction pump - item 112 (ball bearing)

See relevant sectional drawing.

NOTICE:The sump cover (119A) is generally not removed. If it must be removed, remove screws 371S and remove cover. The cover has a sealant between it and the bearing housing. Clean this off carefully. When reinstalling the sump cover (119A) use a uniform bead of Loctite® 5699 between the sump cover and the bearing housing. Be careful to avoid getting sealant in the holes for the cap screws (371S).

1. Make sure that there is adequate access around the pump for inspection and maintenance. Pump must be properly secured and stable before working on it.
2. Remove seal guards (499). These are not shown but cover the openings in the bearing housing.
3. Disconnect any flush piping from the mechanical seal gland and lock the mechanical seal in accordance with manufacturer's recommendation.
4. Unscrew nuts (425) and back off the bearing bracket (228C) using the jacking screw (418).
5. Unscrew cap screws (371C) and confirm that the bearing housing cover (119) is free to move.
6. Remove bearing housing (228C).
7. Remove the bearing housing cover o-ring (412). Do not reuse the o-ring.
8. Bend back the lock washer tab (382) and remove bearing nut (136A) and lock washer (382).
9. Remove bearing (112) with a suitable bearing puller.

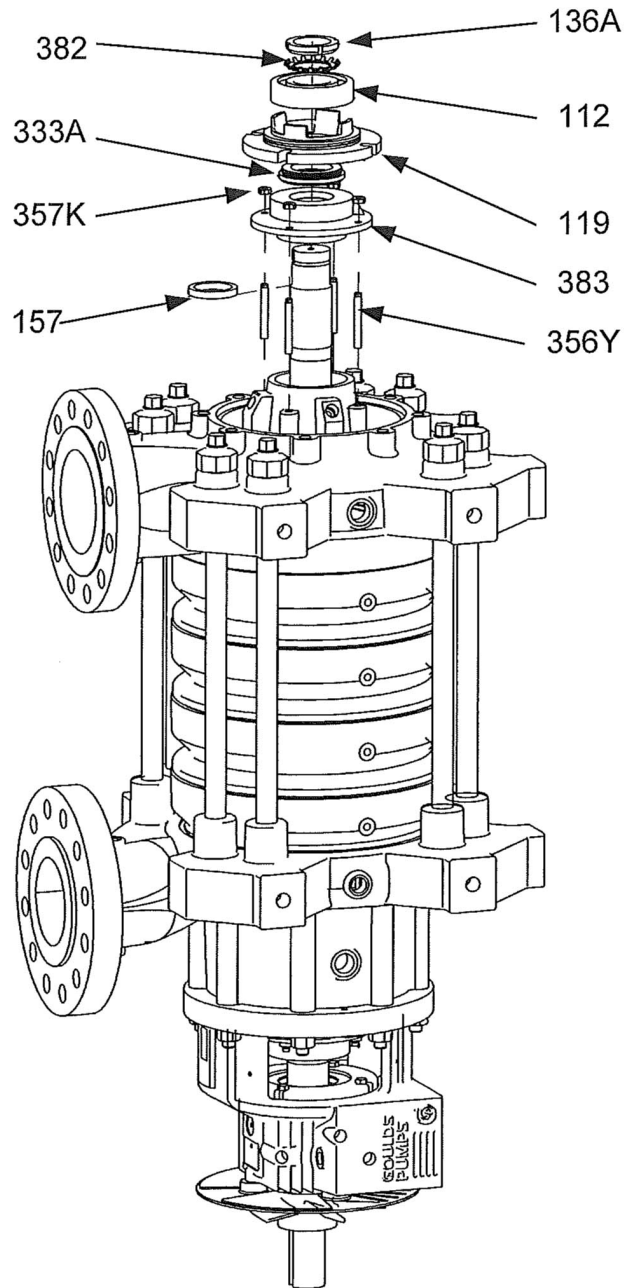

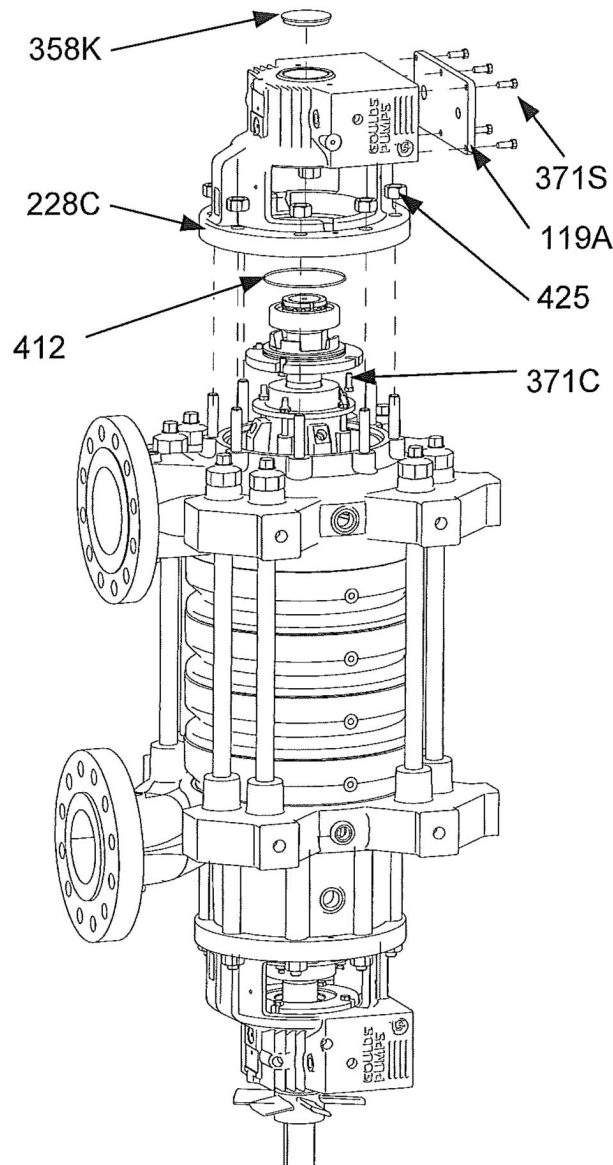

Disassembly of discharge end bearing

End and radial suction pumps - item 409 (ball bearing)

1. Make sure that there is adequate access around the pump for inspection and maintenance. Pump must be properly secured and stable before working on it.
2. Remove coupling halves.
3. Remove seal guards (499).
4. Remove cooling fan (392) if applicable, by loosening set screw (222V).
5. Disconnect any flush piping from the mechanical seal gland.
6. Unscrew nuts (425) and back off the bearing bracket (228C) using the jacking screw (418).
7. Unscrew capscrews (371C) and confirm that the bearing housing cover (119) is free to move.
8. Remove bearing housing (228C).
9. After the bearing bracket (228C) has been removed the shaft can be moved freely in an axial direction (approx. 1/8"). Standard shaft seals can absorb this adjustment without their function being impaired. In the case of special shaft seals, please follow the Operating Instructions of the seal.
10. Remove the bearing housing cover o-ring (412). Do not reuse the o-ring.

11. Bend back the lock washer tab (382) and remove bearing nut (136A) and lock washer (382).
12. Remove ball bearings (409) with the bearing puller.

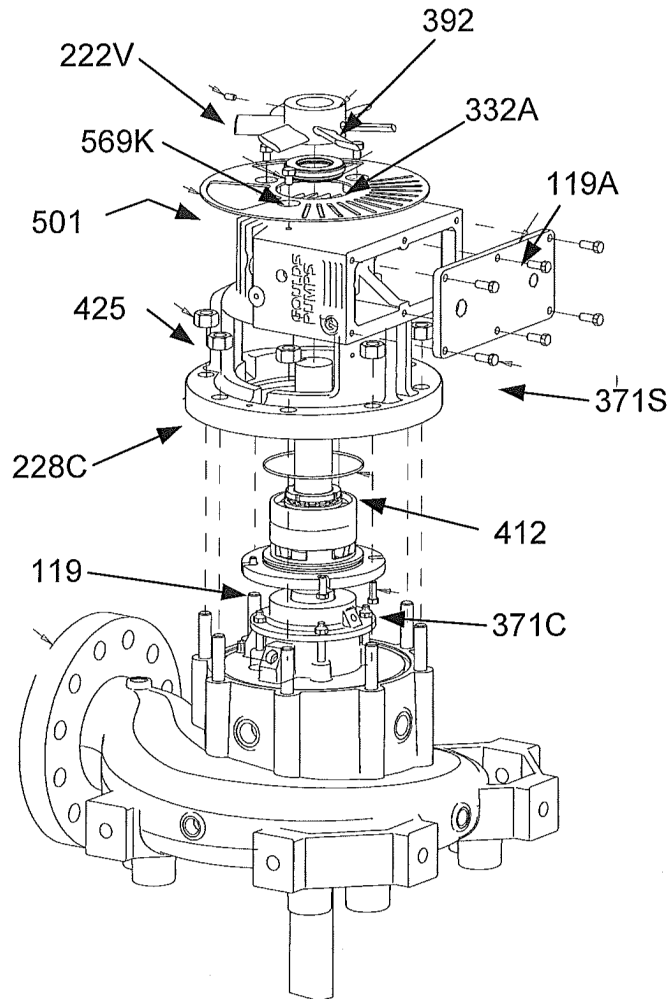

Disassembly of the mechanical seal - end and radial suction pumps

Mechanical seals are located on the suction side (RS configuration) and discharge side (RS and ES configurations). Mechanical seals are cartridge type seals and these instructions refer to cartridge seals. If other seals are used, refer to the seal manufacturer's instructions.



WARNING:

The mechanical seal used in an Ex-classified environment must be properly certified. Prior to startup, make sure that all areas that could leak pumped fluid to the work environment are closed.



CAUTION:

Never operate the pump without liquid supplied to mechanical seal. If you run a mechanical seal dry, even for a few seconds, this can cause seal damage. Physical injury can occur if a mechanical seal fails.

See relevant sectional drawing and mechanical seal vendor's installation instructions.

1. Remove the seal guards (499). These are not shown but cover the openings in the bearing frame.
2. Disconnect any seal flush piping connected to the gland.
3. Locate and reinstall setting clips and clip screws from initial installation if seal is to be reinstalled. This is necessary to properly install seal.

4. Remove the bearings, following appropriate bearing removal instructions above depending on seal location and pump configuration (item 409 and/or item 112).
5. Loosen the set screws holding the seal to the shaft.
6. Remove nuts (357K) holding the mechanical seal (383) to the seal chamber housing (184).
7. Slide entire cartridge seal assembly over the shaft to remove it from the pump.

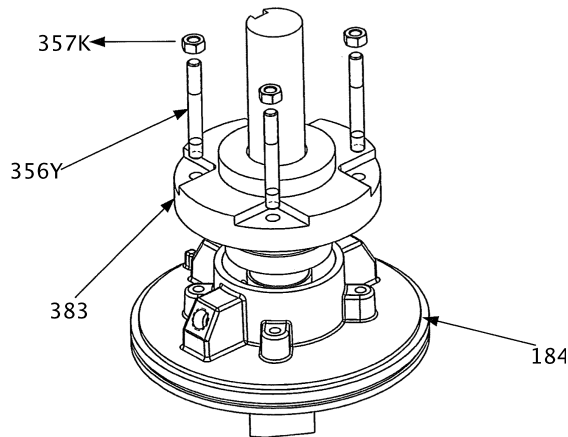

Disassembly of the balance drum rotor and stator - end and radial suction pumps

1. Make sure that there is adequate access around the pump for inspection and maintenance. Pump must be properly secured and stable before working on it.
2. Remove the thrust end bearing housing as noted in instructions for removal of the thrust bearing (item 409).
3. Remove the mechanical seal and gland as noted in instructions for removal of the mechanical seal.
4. Seal chamber (184) and seal chamber o-ring (412H) can now be removed from the discharge casing (100D). Pull the housing toward the shaft end axially.
5. Remove the capscrews (372H) holding balance drum locking plate (519) to the balance drum (300).
6. Remove balance drum locking plate (519) and balance drum locking plate key (178R).
7. Use a permanent marker to place an alignment mark on the shaft and balance drum.
8. Brace the shaft to prevent it from rotating. Insert threaded rods in the balance drum holes and rotate the balance drum by 30° to clear the locking tabs on the shaft.
9. Remove balance drum and balance drum o-ring (412X) using the threaded rod. Do not reuse balance drum o-ring.
10. Insert threaded rods into the balance drum stator and remove axially. Remove balance drum stator (300A) and balance drum stator o-ring (496U). Do not reuse balance drum stator o-ring.
11. Inspect visible portion of the shaft and remove any burrs or scratches with a file and emery cloth.

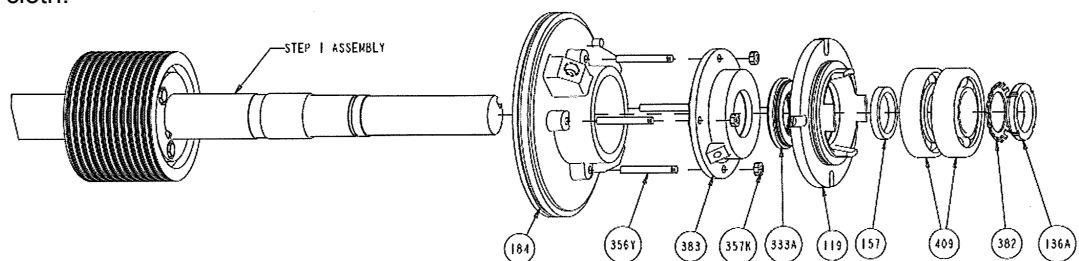

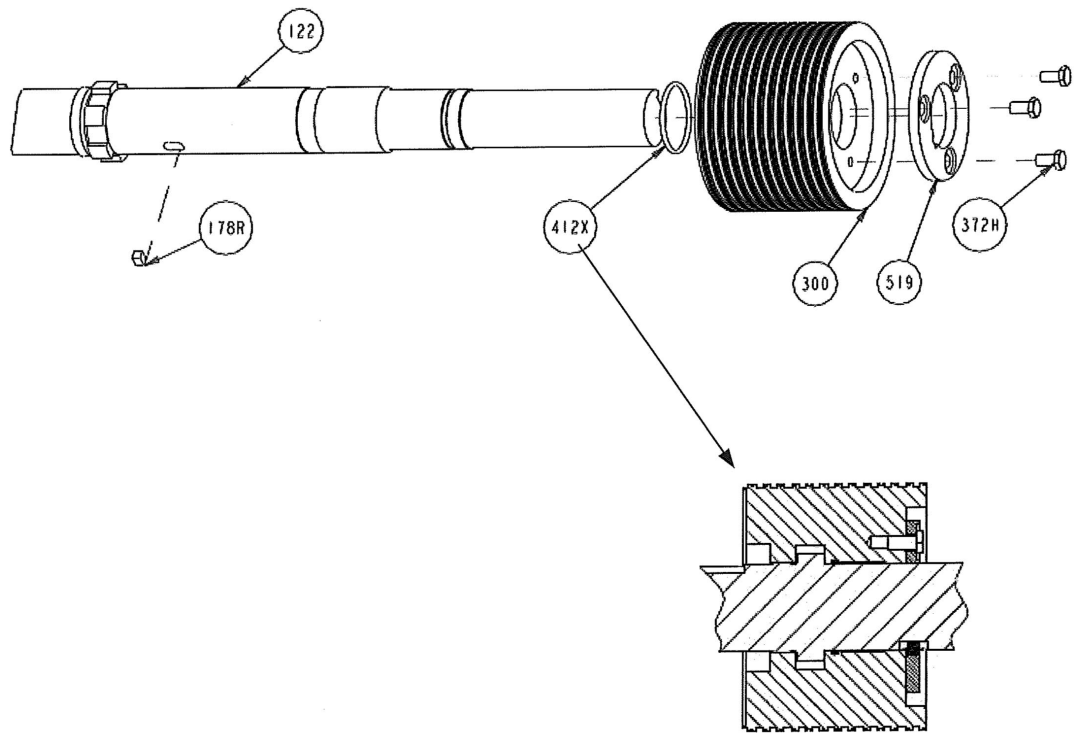

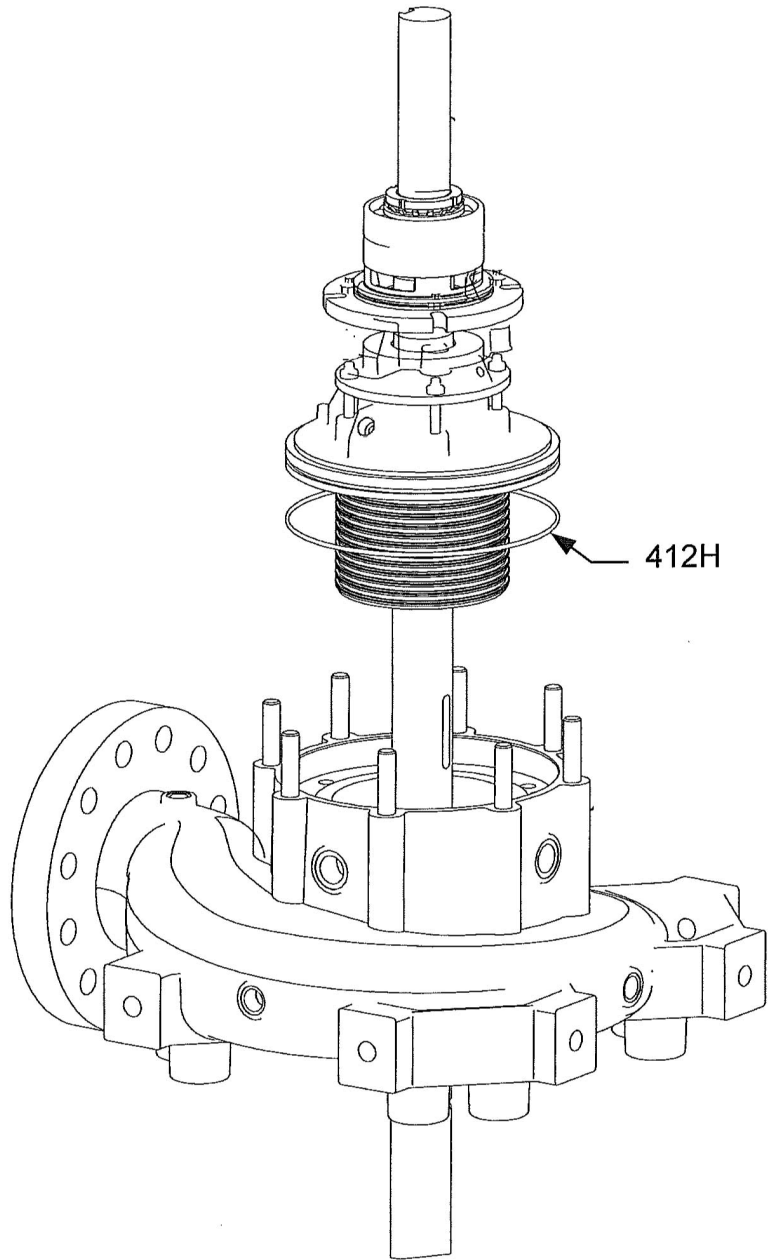

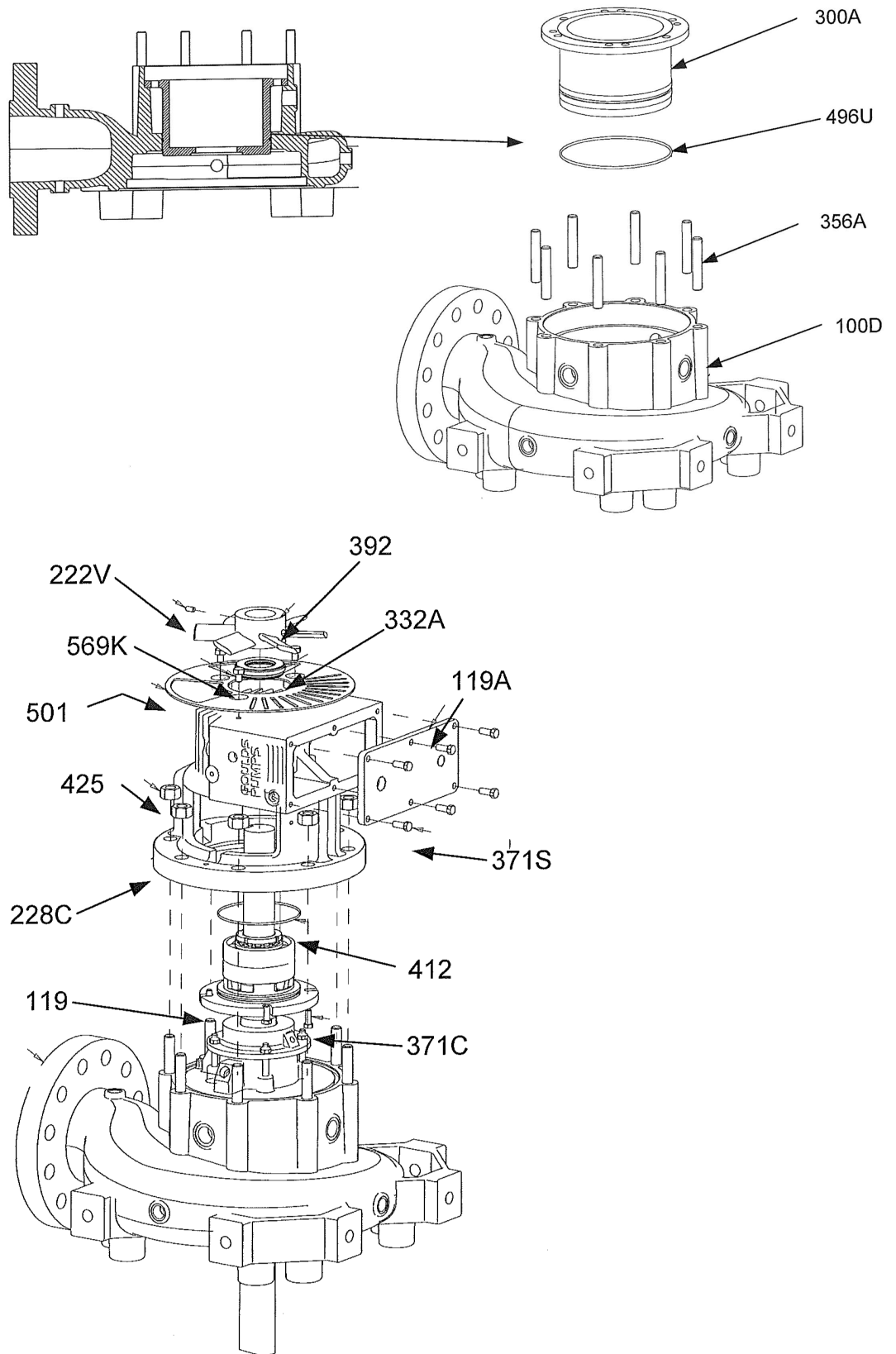

Disassembly of complete pump

End suction pump

See relevant sectional drawing.

To dismantle the whole pump for maintenance work, place it in a vertical position with the suction nozzle facing upwards. It is important that the pump is secured and stable and supported without damaging the bearing housing. A workbench with a hole approximately 1/2" larger than the shaft is helpful in such cases. A hoist or a second person is required for a safe disassembly.



WARNING:

Make sure that the unit cannot roll or fall over and injure people or damage property.

NOTICE:

The pump must be dismantled and assembled in the vertical position.

1. Loosen tie rod nuts (357F) at both ends and remove tie rods (356J). Note: the tie rods are threaded into the discharge casing and must be removed by unscrewing the tie rods using the flats machined into their surface.
2. Remove suction casing (100S) and remove o-ring (412K).
It is not recommended to remove the product lube bearing unless worn or damaged.
3. Loosen retaining ring set screw (352F) and remove the retaining ring (361H) and split ring (214B).
4. Remove impeller (101), impeller key (178), stage casings (100G) and final stage casing (100H) along with stage casing o-rings (412K) and discharge casing o-ring (497D). This step must be done stage by stage down to the discharge casing (100D). Do not reuse o-rings.
5. Invert the pump so the bearing housing (228C) faces upward position.
6. Remove seal guards (499).
7. Remove cooling fan (392) by loosening set screw (222V) if applicable.
8. Disconnect any flush piping from the mechanical seal gland.
9. Unscrew nuts (425) and back off the bearing bracket (228C) using the jacking screw (418).
10. Unscrew capscrews (371C) and confirm that the bearing housing cover (119) is free to move.
11. Remove bearing bracket (228C).
IMPORTANT: After the bearing bracket (228C) has been removed, the shaft can be moved freely in an axial direction approximately 1/8". Standard shaft seals can absorb this adjustment without their function being impaired. For special shaft seals, follow the Operating Instructions of the seal.
12. Remove the bearing housing cover o-ring (412). Do not reuse the o-ring.
13. Bend back the lock washer tab (382) and remove the bearing nut (136A) and the lock washer (382).
14. Remove ball bearings (409) with the bearing puller.
15. Remove the mechanical seal and gland as noted in the instructions for removal of the mechanical seal.
16. Remove the seal chamber (184) and seal chamber o-ring (412H) from the discharge casing (100D).
Pull the housing toward the shaft end axially.
17. Remove cap screws (372H) that hold the balance drum locking plate (519) to the balance drum (300).
18. Remove balance drum locking plate and balance drum locking plate key (178R).
19. Use a permanent marker to place an alignment mark on the shaft and balance drum.
20. Brace the shaft to prevent it from rotating. Insert threaded rods in the balance drum holes and rotate the balance drum by 30° to clear the locking tabs on the shaft.
21. Remove balance drum and balance drum o-ring (412X) using the threaded rod. Do not reuse balance drum o-ring.

22. Insert threaded rods into the balance drum stator and remove axially. Remove balance drum stator (300A) and balance drum stator o-ring (496U). Do not reuse balance drum stator o-ring.

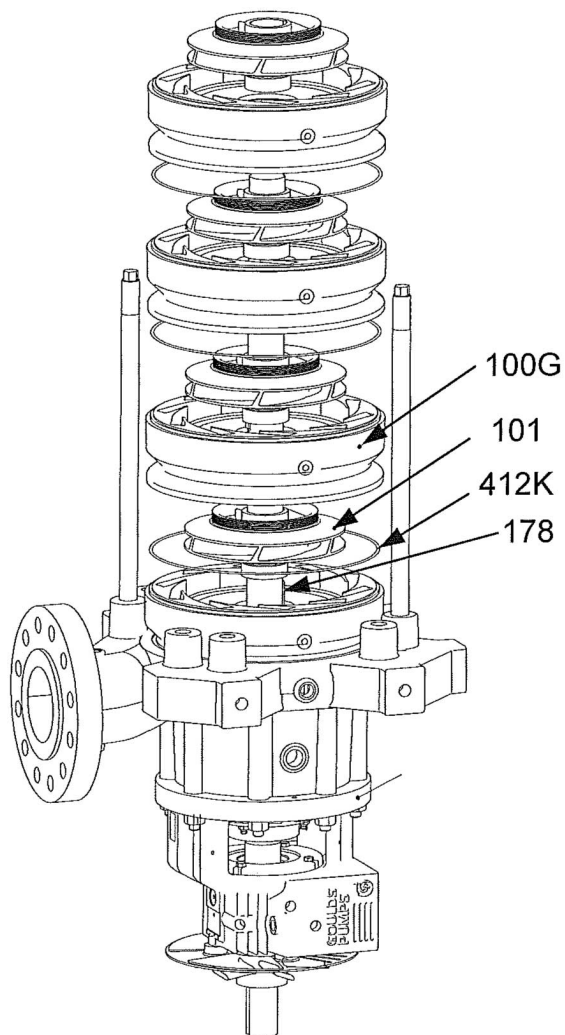

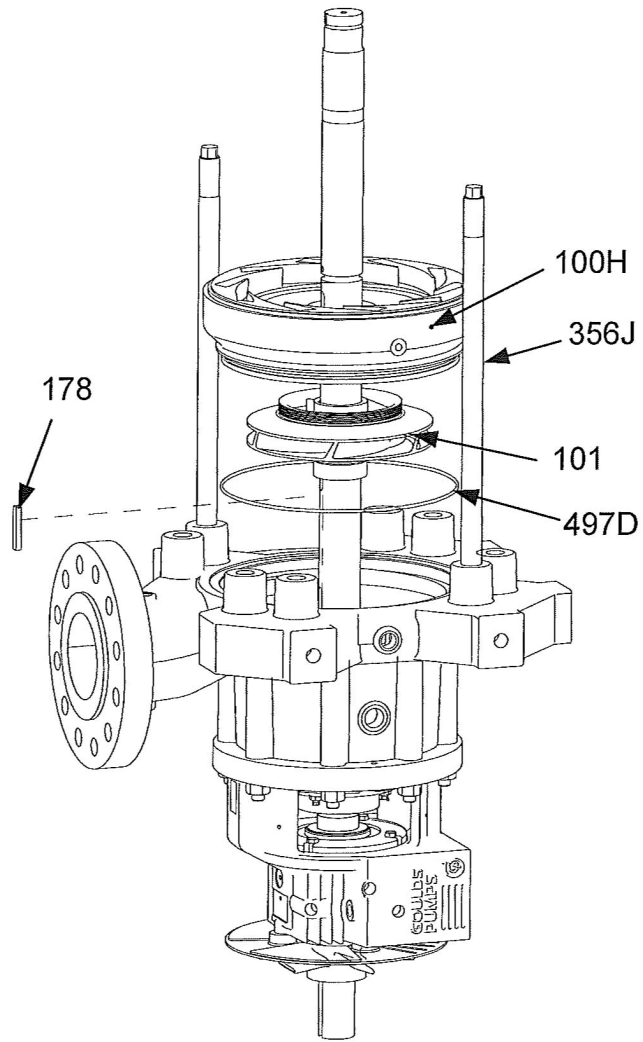

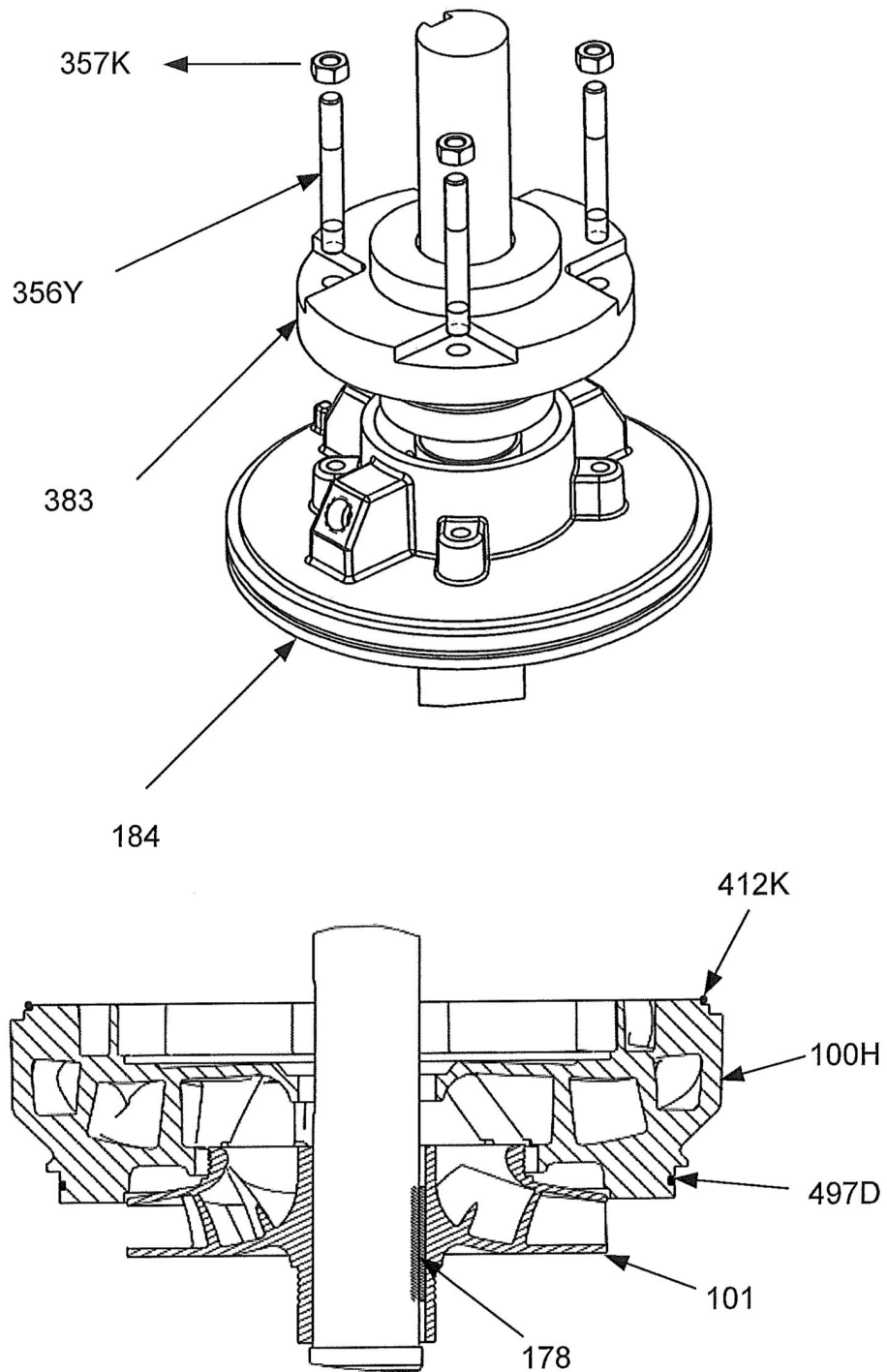

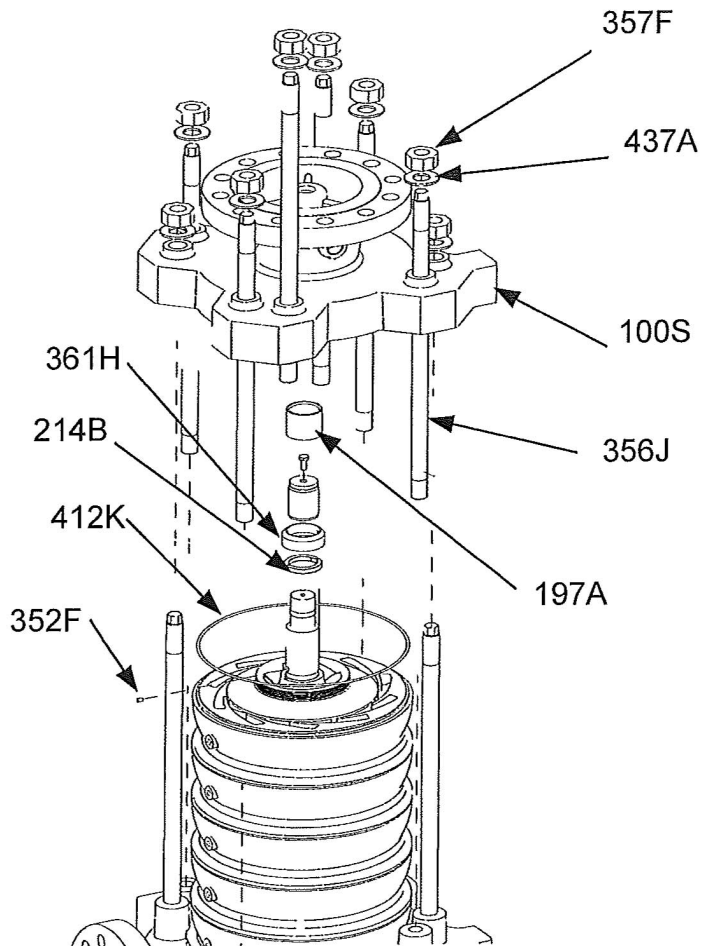
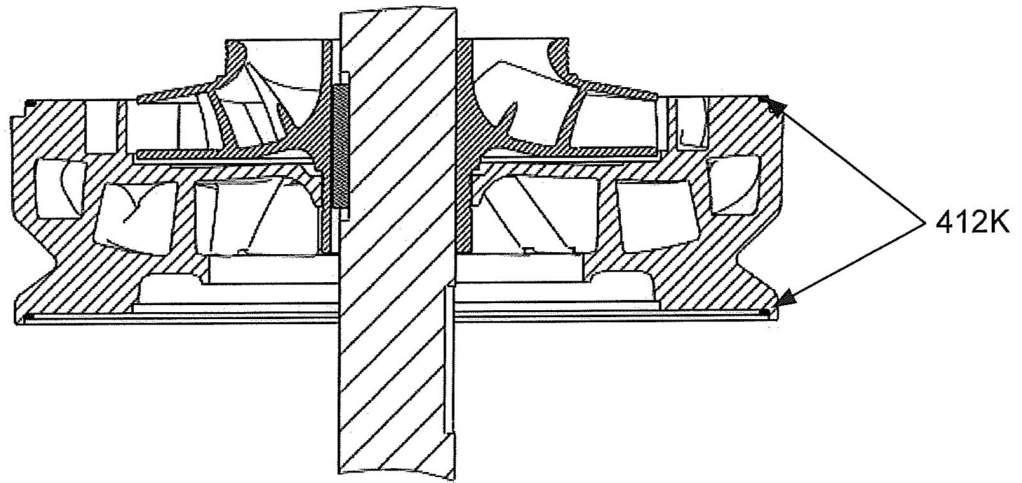

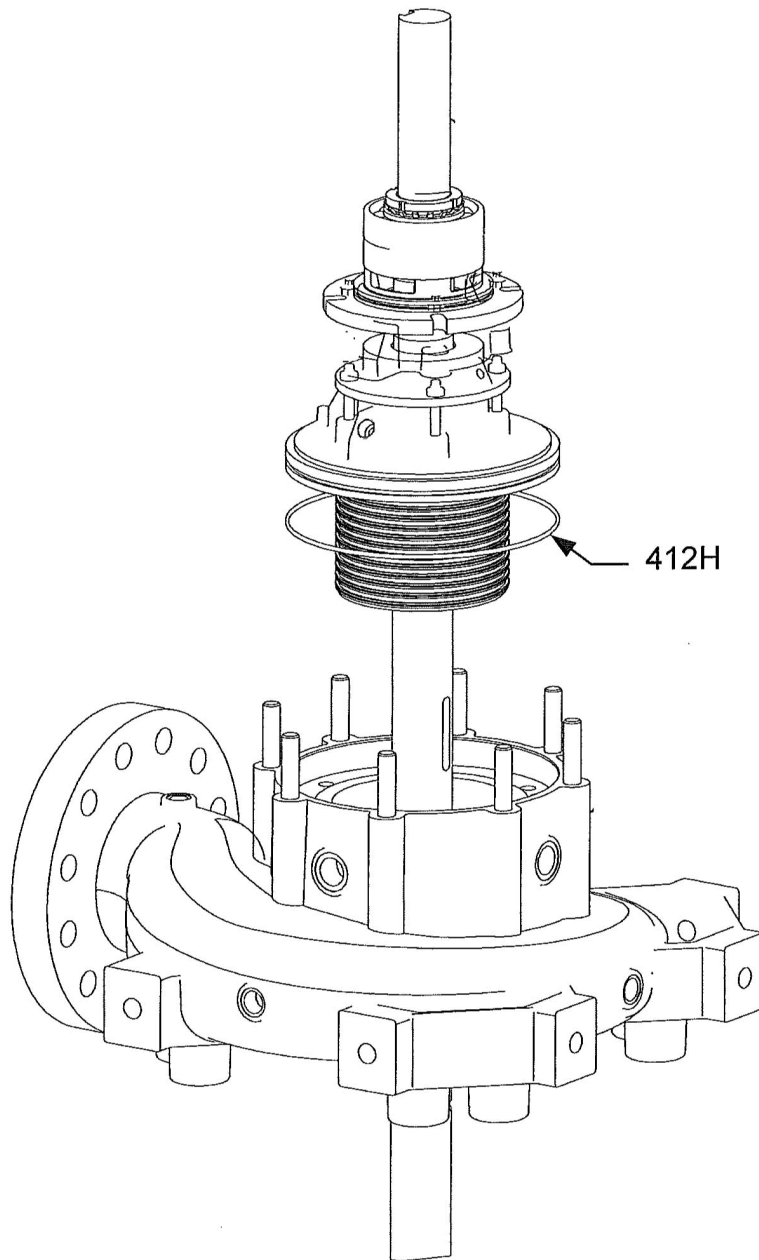

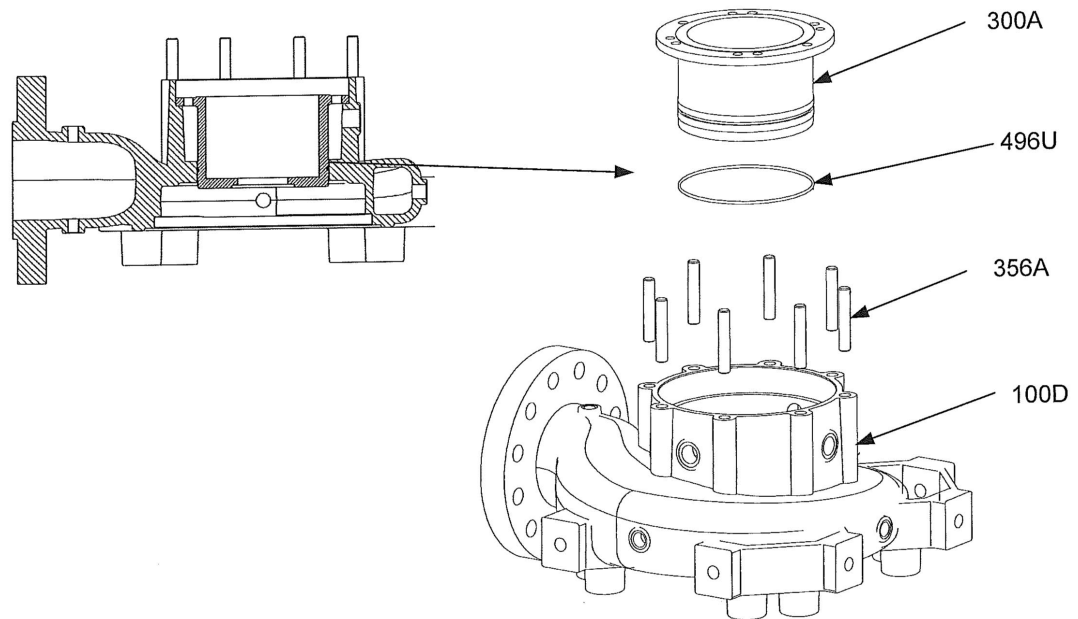

Radial suction pump

See relevant sectional drawing.

To dismantle the whole pump for maintenance work, place it in a vertical position with the suction nozzle facing upwards. It is important that the pump is secured and stable and supported without damaging the bearing housing. A workbench with a hole approximately 1/2" larger than the shaft is helpful in such cases. A hoist or a second person is required for a safe disassembly.



WARNING:

Make sure that the unit cannot roll or fall over and injure people or damage property.

1. Unscrew nuts (425) and back off the bearing bracket (228C) using the jacking screw (418).
2. Unscrew cap screws (371C) and confirm that the bearing housing cover (119) is free to move.
3. Remove bearing housing (228C)
4. Remove the bearing housing cover o-ring (412). Do not reuse the o-ring.
5. Bend back the lock washer tab (382) and remove bearing nut (136A) and lock washer (382).
6. Remove ball bearings (112) with the bearing puller.
7. Remove the mechanical seal and gland as noted in the instructions for removal of the mechanical seal.
8. Loosen tie rod nuts (357F) and remove tie rods (356J). Note: the tie rods are threaded into the discharge casing and must be removed by unscrewing the tie rods using the flats machined into their surface.
9. Remove suction casing (100S) and remove O-ring (412K).
10. Loosen retaining ring set screw ((352F) and remove retaining ring (361H) and split ring (214B).
11. Remove impeller (101), impeller key (178), stage casings (100G) and final stage casing (100H) along with stage casing o-rings (412K) and discharge casing o-ring (497D). This must be done stage by stage down to the discharge casing (100D). Do not reuse o-rings.
12. Invert the pump so the discharge side bearing housing (228C) faces upward position.
13. Remove seal guards (499).
14. Remove cooling fan (392) if applicable, by loosening set screw (222V).
15. Disconnect any flush piping from the mechanical seal gland.

16. Unscrew nuts (425) and back off the bearing housing (228C) using the jacking screw (418).
17. Unscrew cap screws (371C) and confirm that the bearing housing cover (119) is free to move.
18. Remove bearing housing (228C).
19. Remove the bearing housing cover o-ring (412). Do not reuse the o-ring.
20. Bend back the lock washer tab (382) and remove bearing nut (136A) and lock washer (382).
21. Remove ball bearings (409) with the bearing puller.
22. Remove the mechanical seal and gland as noted in the instructions for removal of the mechanical seal.
23. Seal chamber (184) and seal chamber o-ring (412H) can now be removed from the discharge casing (100D). Pull the housing toward the shaft end axially.
24. Remove cap screws (372H) holding balance drum locking plate (519) to balance drum (300).
25. Remove balance drum locking plate and balance drum locking plate key (178R).
26. Using a permanent marker, place an alignment mark on the shaft and balance drum.
27. Brace the shaft to prevent it rotating, insert threaded rods in the balance drum holes and rotate the balance drum by 30° to clear the locking tabs on the shaft.
28. Remove balance drum and balance drum o-ring (412X) using the threaded rod. Do not reuse balance drum o-ring.
29. Insert threaded rods into the balance drum stator and remove axially. Remove balance drum stator (300A) and balance drum stator o--ring (496U). Do not reuse balance drum stator oring.

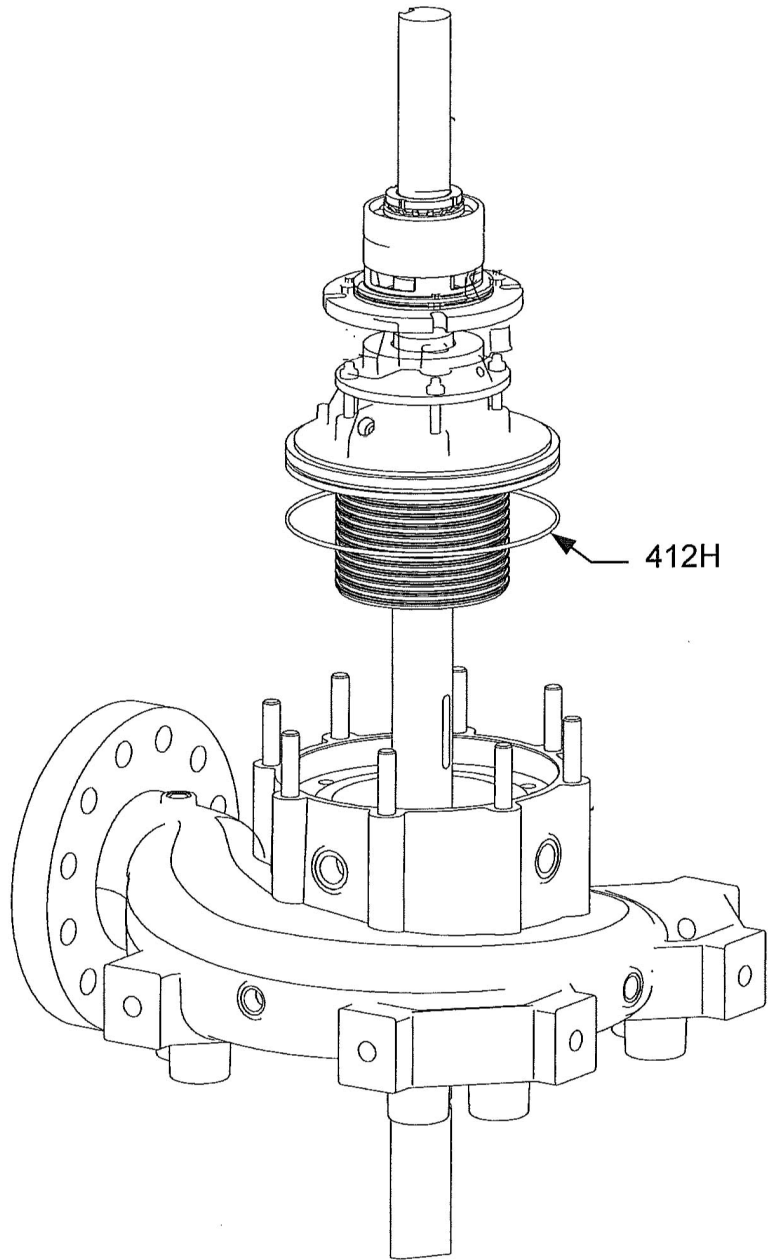

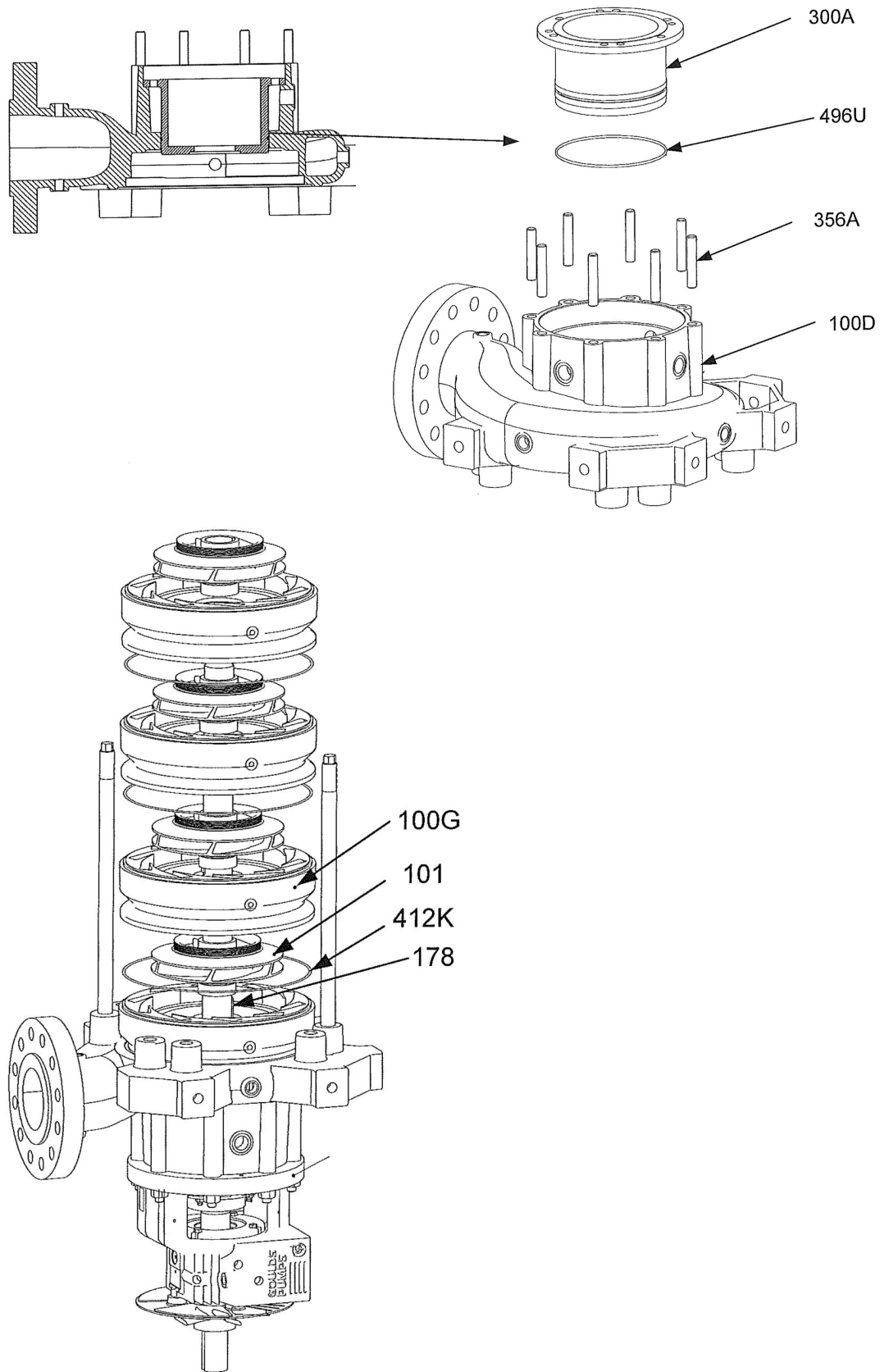

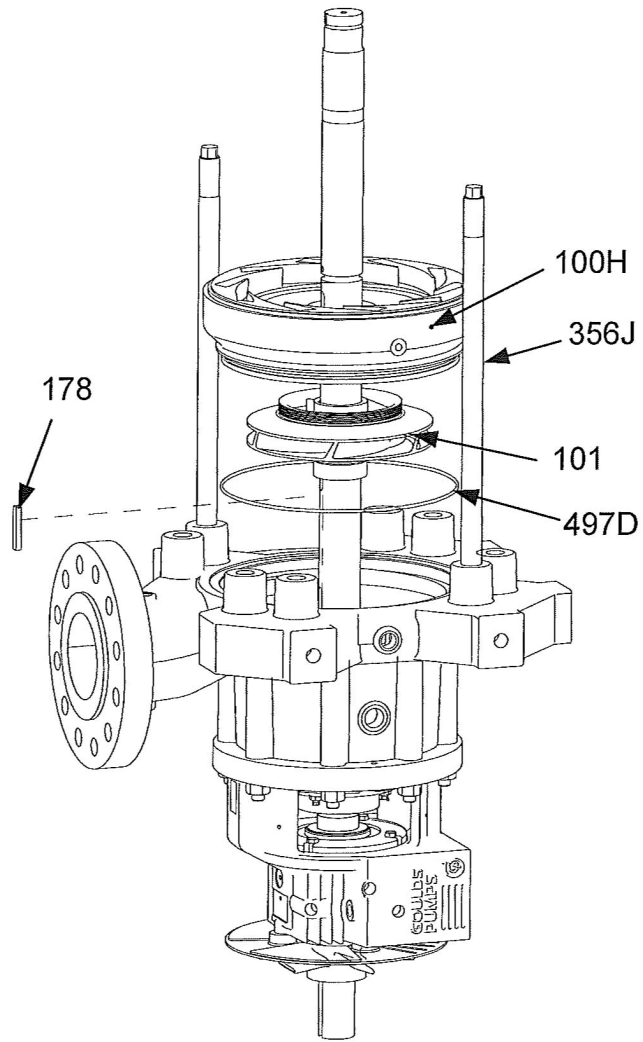

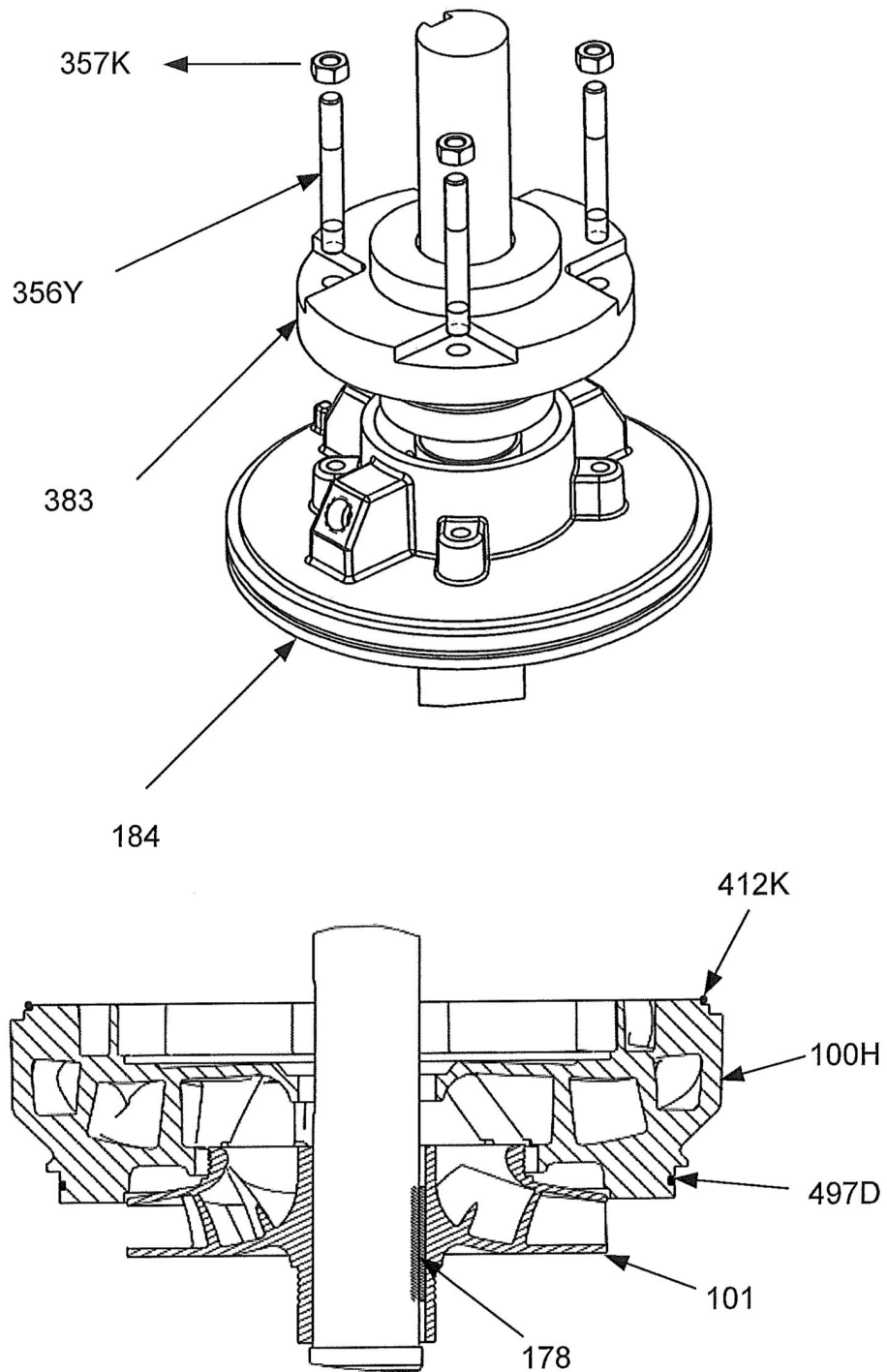

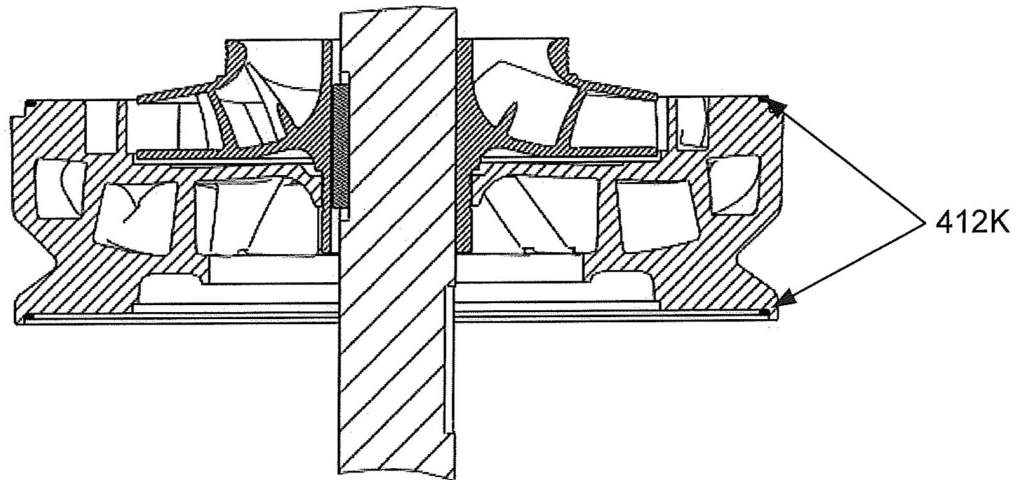

Guidelines for i-ALERT™ Condition Monitor disposal

Precautions



WARNING:

- Never heat the condition monitor to temperatures in excess of 300°F (149°C). Heating to these temperatures could result in death or serious injury.
- Never dispose of the condition monitor in a fire. This could result in death or serious injury.

Guidelines

The battery contained in the condition monitor does not contain enough lithium to qualify as reactive hazardous waste. Use these guidelines when disposing of the condition monitor.

- The condition monitor is safe for disposal in the normal municipal waste stream.
- Adhere to local laws when you dispose of the condition monitor.

Pre-assembly inspections

Guidelines

Before you assemble the pump parts, make sure you follow these guidelines:

- Inspect the pump parts according to the information in these pre-assembly topics before you reassemble your pump. Replace any part that does not meet the required criteria.
- Make sure that the parts are clean. Clean the pump parts in solvent in order to remove oil, grease, and dirt.

NOTICE:

Protect machined surfaces while you clean the parts. Failure to do so may result in equipment damage.

Preassembly inspections

Replacement guidelines

Casing check and replacement

Inspect the casing and diffusers for cracks and excessive wear or pitting. Thoroughly clean o-ring surfaces and alignment fits to remove corrosion and debris.

Repair or replace these parts if you notice any of these conditions:

- Localized wear or grooving that is greater than 1/8 in. (3.2 mm) deep
- Pitting that is greater than 1/8 in. (3.2 mm) deep

- Irregularities in the casing-gasket seat surface
- Wear ring and balance drum clearances that exceed the values in the running clearances table

NOTICE:

When clearances between the rings become excessive (increase by 100%), hydraulic performance decreases substantially.

Casing areas to inspect

The arrows point to the areas to inspect for wear on the casing:

Casing Parts	When to Replace
Cutwaters on casings, inlet and outlet vanes on diffusers	<ul style="list-style-type: none"> • When grooved deeper than 1/16 in. (1.6 mm), or • When worn evenly more than 1/32 in. (0.8 mm)
Vane edges	When you see cracks, pitting, or corrosion damage
Wear ring surfaces	When the clearance to the casing wear ring has increased by 100% over the values in the running clearances table

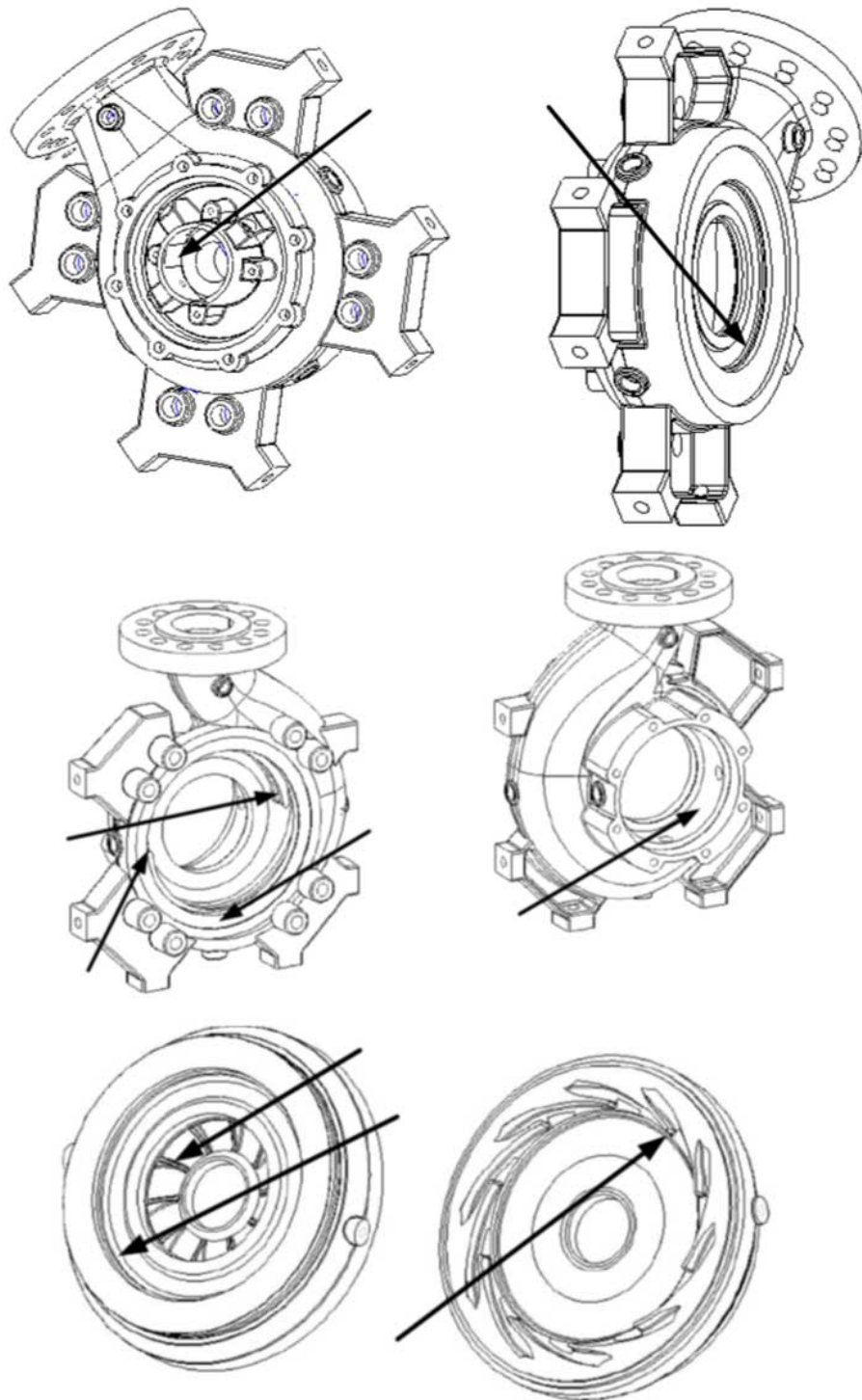

Impeller replacement

This table shows the criteria for replacing the impeller:

Impeller Parts	When to Replace
Impeller vanes	<ul style="list-style-type: none"> • When grooved deeper than 1/16 in. (1.6 mm), or • When worn evenly more than 1/32 in. (0.8 mm)
Vane edges	When you see cracks, pitting, or corrosion damage
Wear ring surfaces	When the clearance to the casing wear ring has increased by 100% over the values in the running clearances table

Impeller checks

- Check and clean the impeller bore diameter.
- Check the impeller balance. Rebalance the impeller if it exceeds the ISO G 6.3 criteria.

NOTICE:

You must have accurate tooling equipment to balance impellers to the ISO G 6.3 criteria. Do not attempt to balance impellers to this criteria unless this type of tooling and equipment is available.

Impeller areas to inspect

- A. Shroud
- B. Wear Ring (if supplied)
- C. Vane

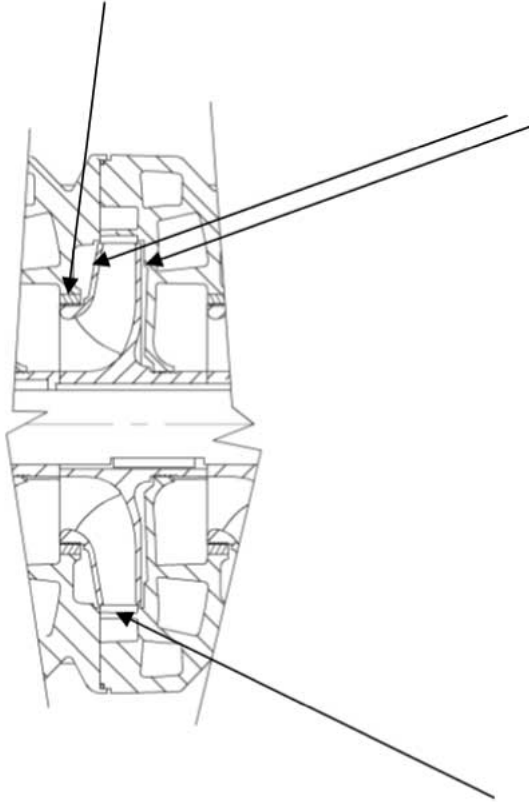
**Balance drum areas to inspect**

Balance drum surfaces must be smooth and free of grooves and scratches, especially in the areas indicated by arrows in the figure. Also check the outside diameter of the balance drum.

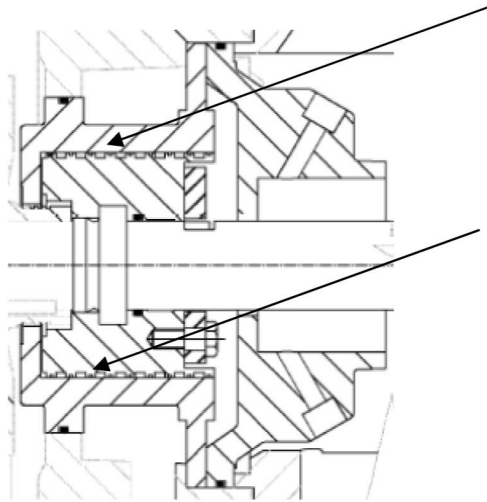

Cartridge mechanical seal replacement

Cartridge-type mechanical seals should be serviced by the seal manufacturer. Refer to the instructions from the mechanical seal manufacturer for assistance.

Coupling guard replacement

Repair or replace the coupling guard if you notice corrosion or other defects.

O-rings, and seats replacement

- Replace all gaskets and O-rings at each overhaul and disassembly.
- Inspect the seats. They must be smooth and free of physical defects
- Replace parts if the seats are defective.

Additional parts

Inspect and either repair or replace all other parts, if inspection indicates continued use would be harmful to satisfactory and safe pump operation.

Inspection must include these items:

- Bearing end covers (119)
- Labyrinth seals (332A and 333A)
- Bearing locknut (136A)
- Impeller key (178), coupling key (400) and balance drum key (178R)
- Bearing lockwasher (382)
- All nuts, bolts, and screws

Shaft replacement guidelines

Shaft measurement check

Check the bearing fits of the shaft. If any are outside the tolerances shown in the Bearing fits and tolerances table, then replace the shaft.

Shaft straightness check

Check the shaft straightness. Use "V" blocks or balance rollers to support the shaft on the bearing fit areas. Replace the shaft if runout exceeds the values in the Shaft and rotor runout requirements table.

Do not use shaft centers for the runout check as they may have been damaged during the removal of the bearings or impeller.

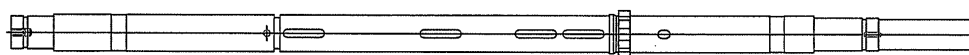

Shaft surface check

Check the shaft surface for damage. Remove any burrs. Replace the shaft if it shows fretting or gouging or is damaged beyond reasonable repair.

Rotor

Allowable runouts of the fully assembled rotor are listed in the Shaft and rotor runout requirements table.

Table 2: Shaft and rotor runout requirements

Characteristic	Requirement
Allowable shaft runout, TIR*	0.05 mm (0.0020 in.)
Component fit to shaft	Clearance
Allowable rotor radial runout, TIR*	0.10 mm (0.0040 in.)
*Total indicated runout of impeller hubs and sleeves	

Bearings inspection

Condition of bearings

Do not reuse bearings. The condition of the old bearings provides useful information on operating conditions in the bearing frame.

Checklist

Perform these checks when you inspect the old bearings:

- Inspect the bearings for contamination and damage.
- Note any lubricant condition and residue.
- Inspect the ball bearings to see if they are loose, rough, or noisy when you rotate them.
- Investigate any bearing damage to determine the cause. If the cause is not normal wear, correct the issue before you return the pump to service.

Replacement bearings

Replacement bearings must be the same as, or equivalent to, those listed in this table.

Notice:

Thrust bearings must have machined bronze cages (retainers)

Table 3: Model 3393 ball bearing fits

Pump Size	Radial Bearing	Thrust Bearing	Bearing Housing Bore	Shaft turn
2.5x4-8	6408	7408 BCBM	4.3321 in. / 4.3307 in. / 110.035 mm / 110.00 mm	1.5755 in. / 1.5749 in. / 40.018 mm / 40.002 mm
4x5-10	6409	7409 BCBM	1.7258 in. / 4.7244 in. / 120.035 mm / 120.00 mm	1.7724 in. / 1.7717 in. / 45.018 mm / 45.002 mm
5x6-11	6311	7311 BECBM	4.7258 in. / 4.7244 in. / 120.035 mm / 120.00 mm	2.1662 in. / 2.1654 in. / 55.021 mm / 55.002 mm
6x8-13	6214	7214 BECBM	4.9228 in. / 4.9213 in. / 125.040 mm / 125.006 mm	2.7567 in. / 2.7560 in. / 70.020 mm / 70.002 mm

Bearing Housings

Perform these checks when you inspect the bearing housings:

- Check that the bearing housings are very clean, with no burrs.
- Remove all loose and foreign material.
- Check the bearing housing bores against the values in the Ball bearing fits table.
- Repair or replace housings as necessary.

Replace the casing and diffuser wear rings

Check for obvious damage and excessive clearance and if necessary replace the casing and diffuser wear rings. The casing and diffuser wear rings (103) are held in place by a press fit and Loctite® 635.

1. Remove the wear rings from the suction casing (100S) and the diffusers (100H). Use suitable pry or puller tools to force the rings from the fits. You can also machine the rings for removal.



CAUTION:

Make sure that the unit cannot roll or fall over and injure people or damage property.

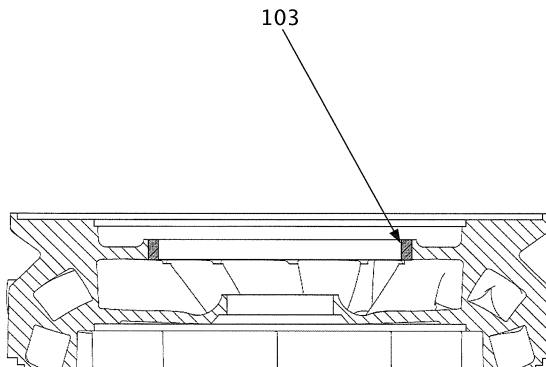
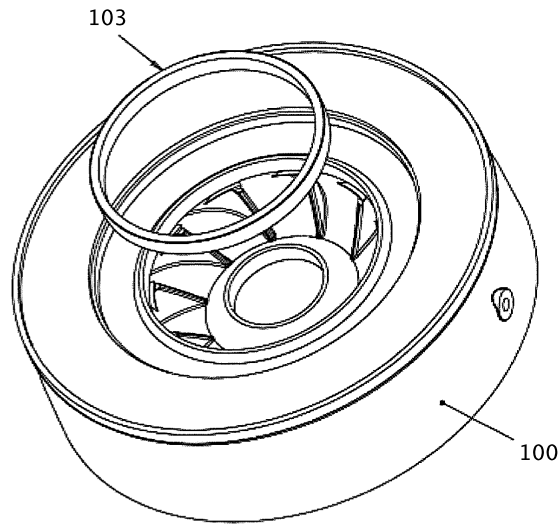

2. Install the wear rings:

- a. Thoroughly clean the wear ring seats and make sure they are smooth and free of scratches.
- b. Chill the new wear rings (103) using dry ice or other suitable chilling substance and install the rings into the fit of the suction casing (100S) and the diffusers (100H). Use Loctite 635 between the casing and casing wear ring. Be prepared to tap the ring in place with a hardwood block or a soft-faced hammer.

NOTICE:The impeller and wear ring clearance setting procedure must be followed. Improperly setting the clearance or not following any of the proper procedures can result in sparks, unexpected heat generation and equipment damage.

3. Check the suction casing and diffuser wear rings (103) runout and distortion by measuring the bore at three (3) locations 120° apart with inside micrometers or vernier calipers.

Replace the impeller wear rings (Optional - may not be on all pumps)

Impeller wear rings are an option. A press fit and three tack welds hold the impeller wear rings (142) in place.

1. Remove the impeller wear rings (142) by grinding out the tack welds and using suitable pry or puller tools to force the wear rings from the impeller. If this is impractical, the wear rings may be ground off.
2. Clean the impeller hubs thoroughly to make sure they are smooth and free of scratches
3. Heat the new impeller wear rings to between 180°F (82°C) and 200°F (93°C) using a uniform method for heating, such as an oven, and place them on the impeller (101) hub in the correct location..
4. Tack weld each ring in three places 120° apart.

Note: It may be necessary to replace the impellers.

Reassembly

Preliminary work



WARNING:

Make sure that the unit cannot roll or fall over and injure people or damage property.

Ensure that there is adequate space to safely work on the pump. Make sure pump is stable and secured from tipping over. Insure all parts are available and that any parts being reused are clean and dry.

Assembly of suction end bearing

End suction pump - item 117 (sleeve bearing)

Do not reuse 505D (tolerance ring) or 412K (o-ring).

1. Clean the fitting surfaces between the bearing sleeve (197A) and suction casing (100S).
2. Coat the casing bearing bore and the outside of the stationary bearing (197A) with Loctite 635
3. Insert bearing sleeve (197A) into the casing. This can be facilitated by placing the bearing sleeve in a freezer for approximately one hour and heating the suction casing with hot water. When the casing has been heated, insert the bearing sleeve into the casing bore. The greater the temperature difference between the bore and the sleeve, the easier it will be to insert the bearing sleeve. An assembly fixture that can aid in this portion of the assembly can be made or can be purchased from Goulds.
4. Replace tolerance rings (505D) and sleeve bearing (117) on the end of the shaft
5. Replace cap screw (469Y) and retaining plate (467) on the end of the shaft.
6. Place o-ring (412K) in position on the diffuser.
7. Replace suction casing (100S) and align with the shaft.
8. Reinstall tie rod nuts (357F) and tie rod washers (437A) on tie rods and tighten to correct torque values as noted in Appendix A. Tighten in sequence and increments as noted in Appendix D.

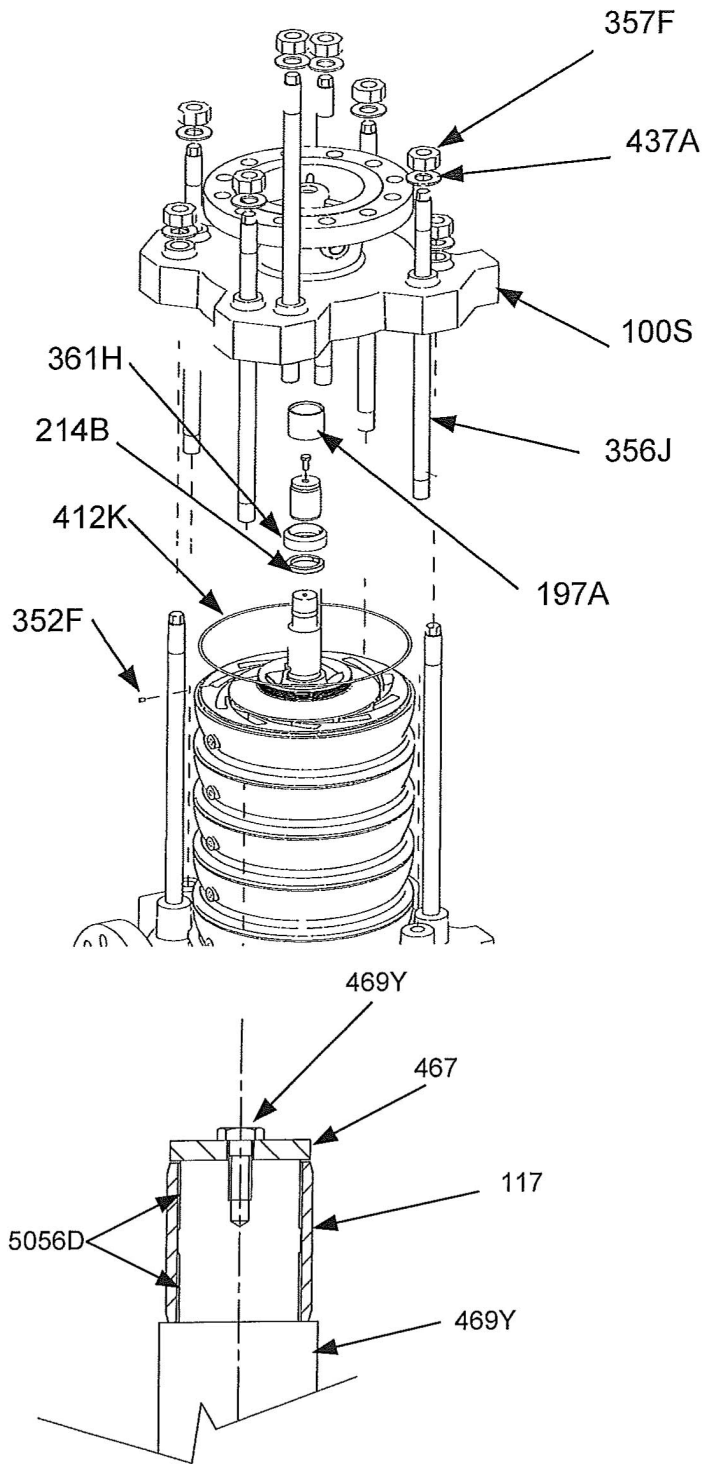

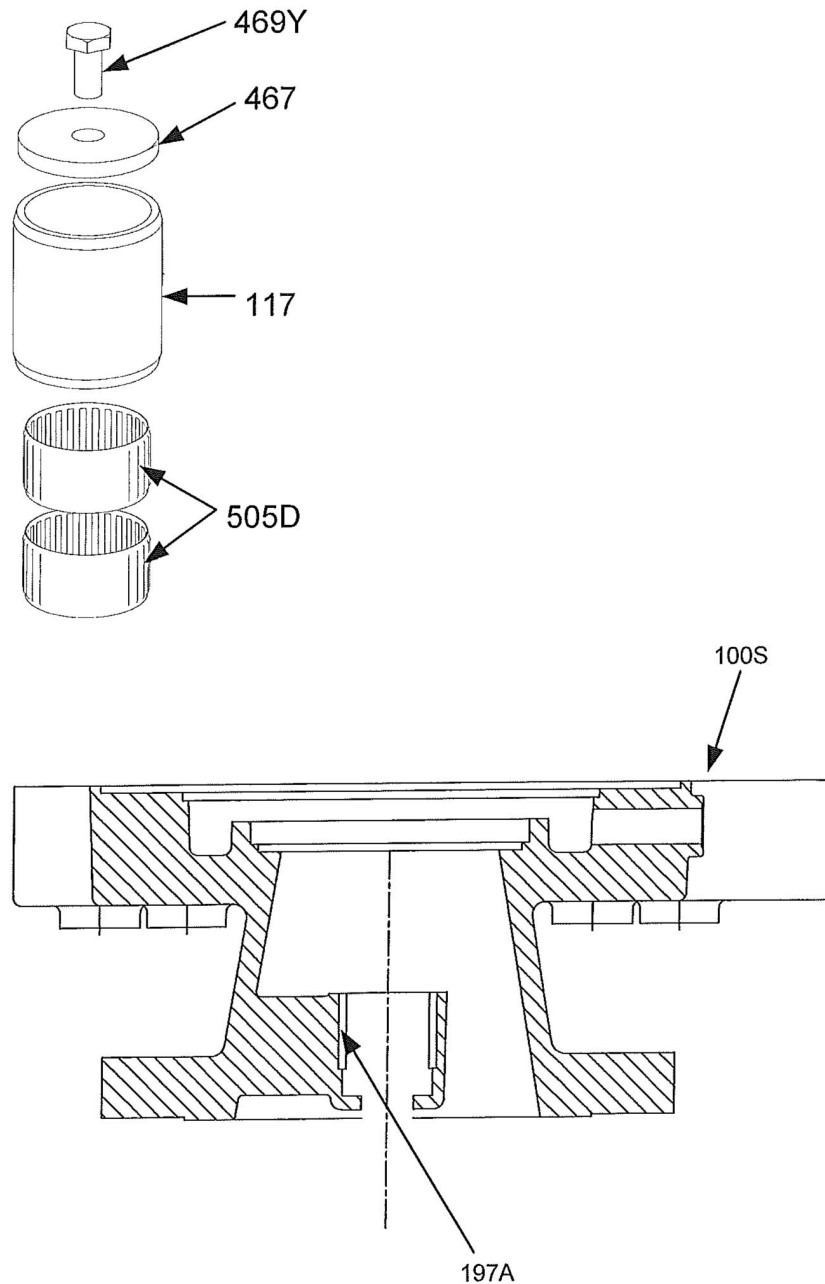

Radial suction pump - item 112 (ball bearing)

1. Clean and lubricate the fitting surfaces between the bearing bracket (228C) and discharge casing (110D).
2. Position the bearing cover (119) with the bearing isolator (333A) over the shaft.
3. Verify that the bearing spacer (157) is in place against the shaft shoulder.
4. Preheat the new bearing (112) (max. 230°F) and slide onto the shaft (122).
5. Replace bearing lockwasher (382) and bearing nut (136A).
6. Allow the bearing (112) to cool to room temperature.
7. Tighten the bearing locknut (136A) until resistance is felt.
8. Replace the bearing housing (228C) and align with the shaft (122) and seal chamber (184).
9. Reinstall and tighten nuts (425) to proper torque values.
10. Install the bearing cover (119) to the bearing housing with cap screws (371C) and tighten to correct torque values. NOTE: the drain hole in the isolator must be at bottom dead center when the pump is in the horizontal position.
11. Connect flush piping to gland.

12. Refit the seal guards (499).

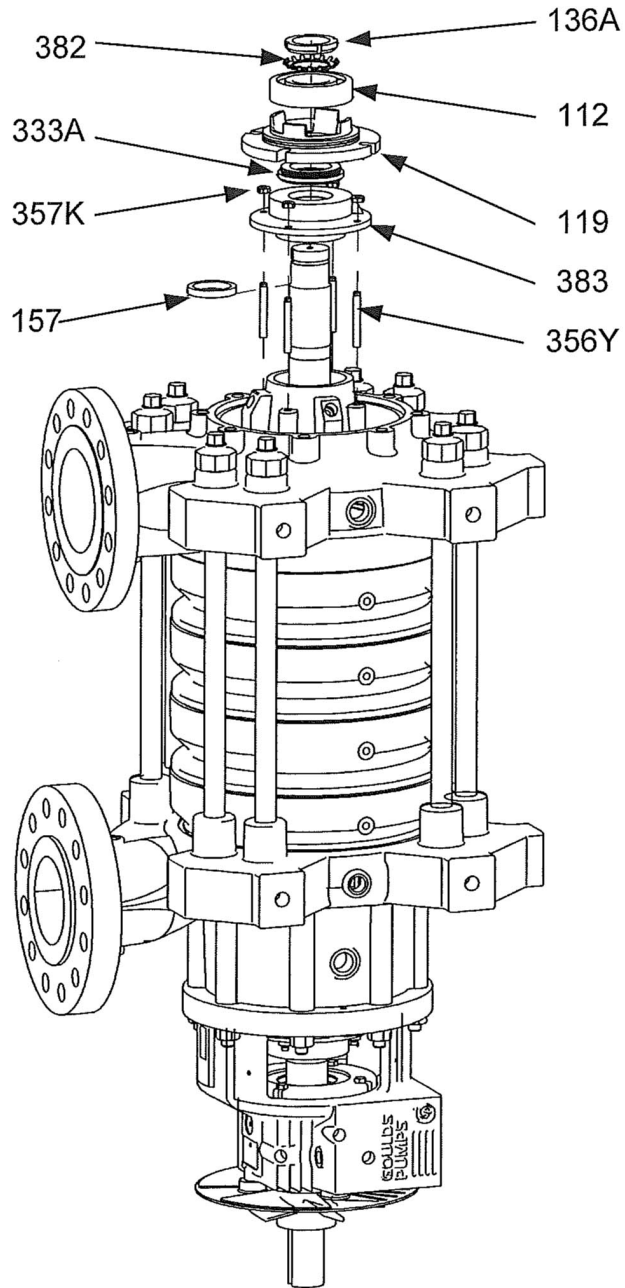

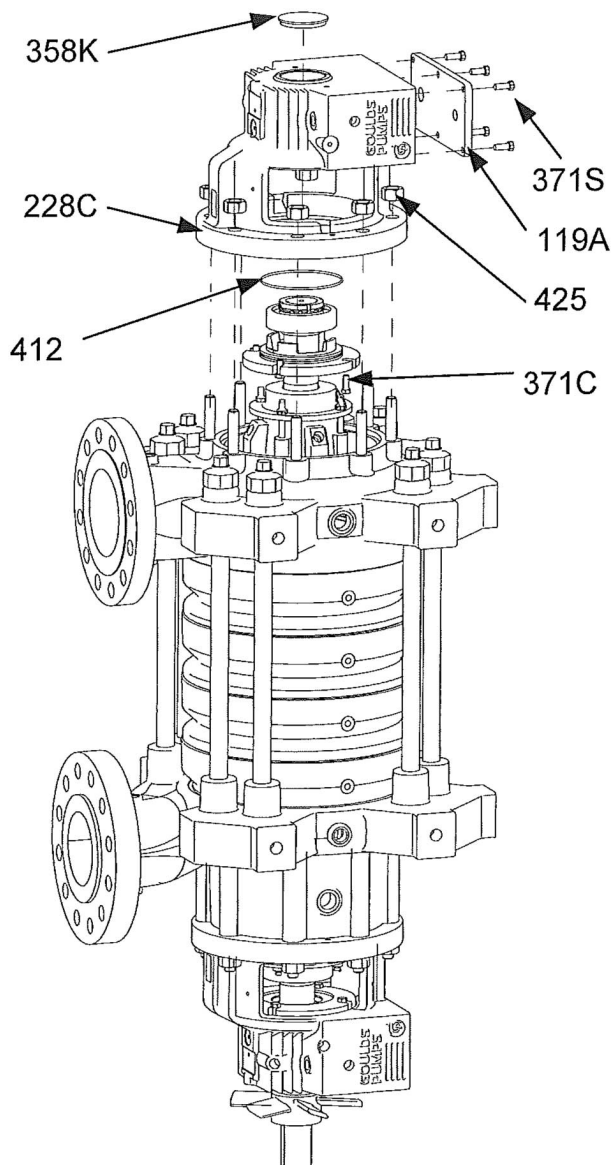

Assembly of discharge end bearing

End and radial suction pump - item 409 (ball bearing)

1. Clean and lubricate the fitting surfaces between the bearing bracket (228C) and discharge casing (110D).
2. Position the bearing cover (119) with the bearing isolator (333A) over the shaft.
3. Verify that the bearing spacer (157) is in place against the shaft shoulder.
4. Preheat the new bearing (409) (max. 230°F) and slide onto the shaft (122) in a back to back arrangement.
5. Replace bearing lockwasher (382) and bearing nut (136A).
6. Allow the bearings (409) to cool to room temperature.
7. Tighten the bearing locknut (136A) until resistance is felt when rotating the bearing outer races in opposite directions by hand.
8. Replace the bearing bracket (228C) and align with the shaft (122) and seal chamber (184).
9. Reinstall and tighten nuts (425) to proper torque values.
10. Install the bearing cover (119) to the bearing housing with cap screws (371C) and tighten to correct torque values.

11. Install or confirm that the bearing isolator (332A) is properly installed in the bearing housing.

NOTICE: The drain hole in the isolator must be at bottom dead center when the pump is in the horizontal position.

12. Replace cooling fan (392) if applicable.
13. Mount coupling half (may preheat to max. 230°F).
14. Connect flush piping to gland.
15. Refit the seal guards (499).

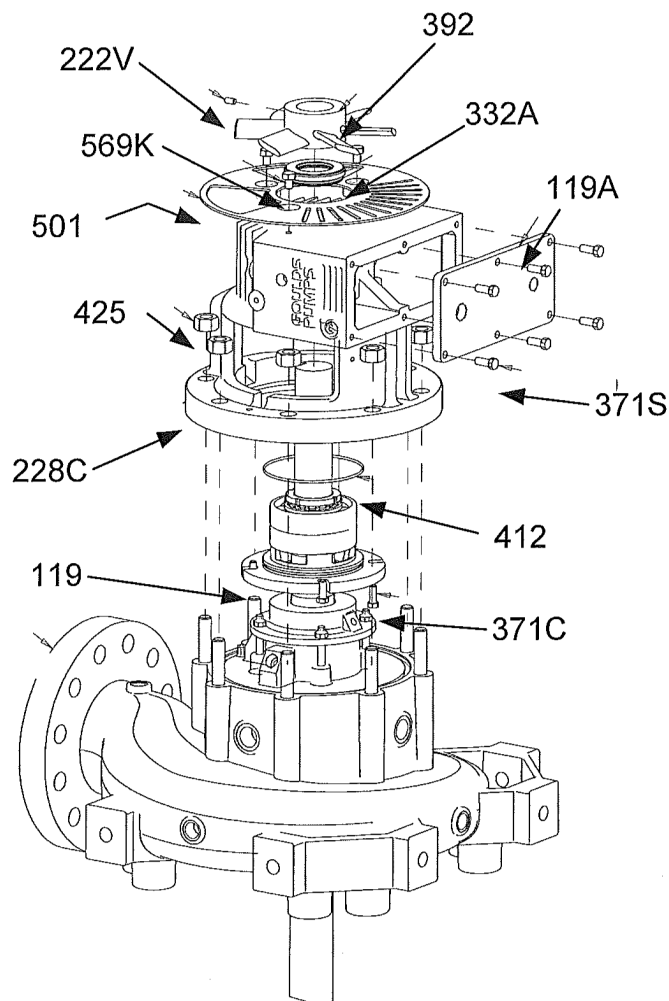
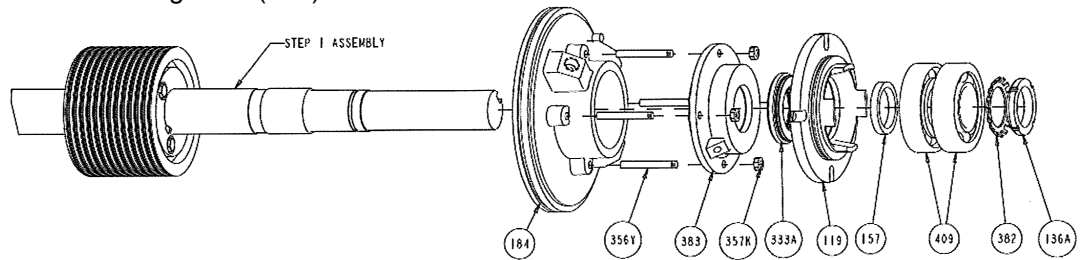

Outer races have resistance when turned
in opposite rotations by hand

Bearing Mounting Back to Back

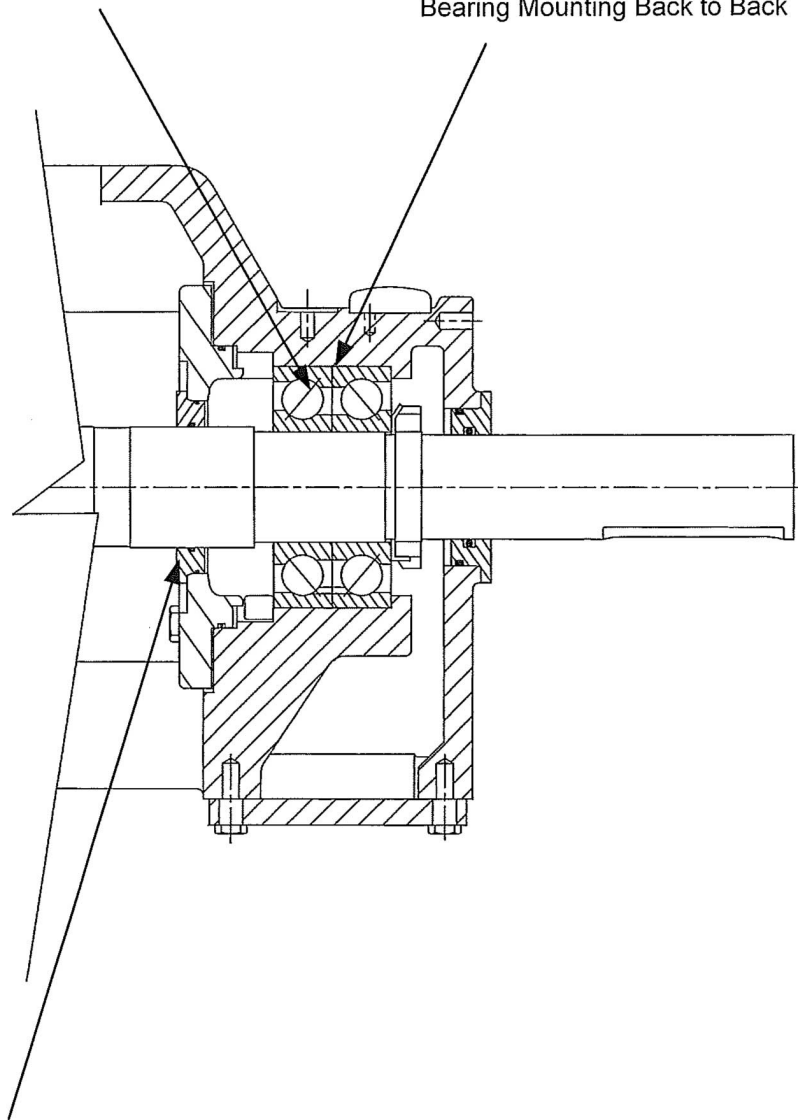

Install Isolator (333A) so that drain hole is at the bottom.

Assembly of mechanical seal - end and radial suction pumps

Mechanical seals are cartridge type seals and these instructions refer to cartridge seals. If other seals are used, refer to the seal manufacturer's instructions.

1. Lubricate the shaft with the assembly lubricant provided with the mechanical seal (383).
2. Slide seal over shaft and into position. Make sure gland connections are orientated properly for required flush piping.
3. Reinstall the bearings following appropriate bearing assembly instructions above depending on seal location and pump configuration.
4. Install and tighten seal chamber nuts (357K).
5. Tighten the set screws holding the seal to the shaft.
6. Remove setting clips and retain for future use.
7. Rotate the shaft to see that it turns smoothly.
8. Install flush piping to seal gland.

9. Install the seal guard (499). These are not shown but cover the openings in the bearing frame.

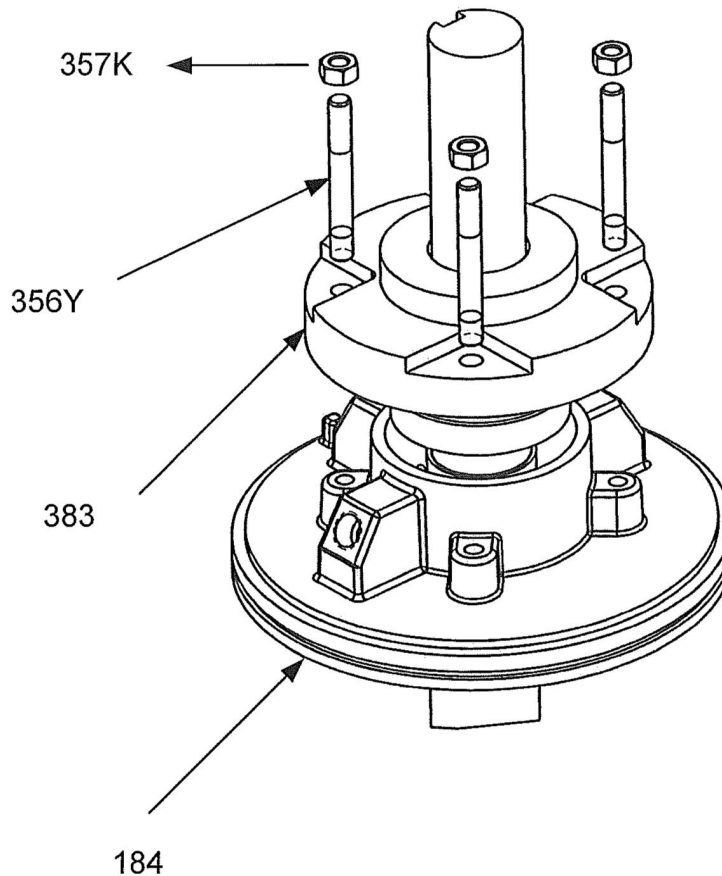

Assembly of the balance drum rotor and stator - end and radial suction pumps

NOTICE: Take care not to damage the shaft (122) during reassembly.

1. Replace balance drum stator (300A) and balance drum stator o-ring (496U).
2. Replace balance drum rotor (300) and balance drum rotor o-ring (4112X). Balance drum rotor must be rotated approximately 30° to lock it into place. Use the alignment marks placed during disassembly as a guide.
3. Insert balance drum locking plate key (178R) in shaft and slide balance drum locking plate (519) over key and secure it to balance drum with capscrews (372H).
4. Replace seal chamber (184) by inserting the lip on the flat surface of the seal chamber into the positioning groove in the balance drum stator.
5. Replace mechanical seal and gland as noted in instructions for assembly of mechanical seal.
6. Replace thrust end bearing housing as noted in instructions for assembly of thrust bearing (item 409).

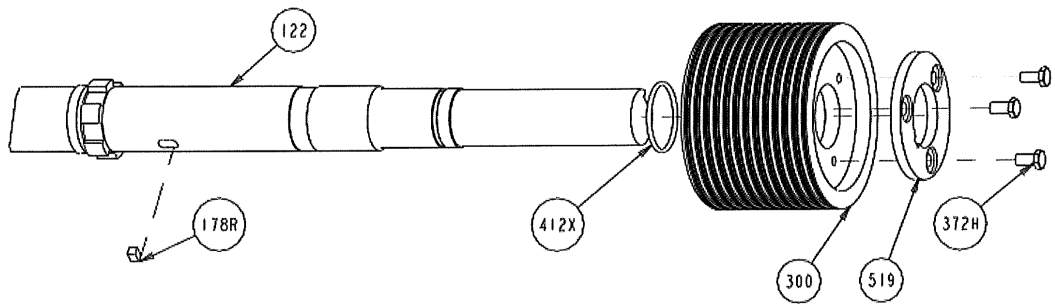
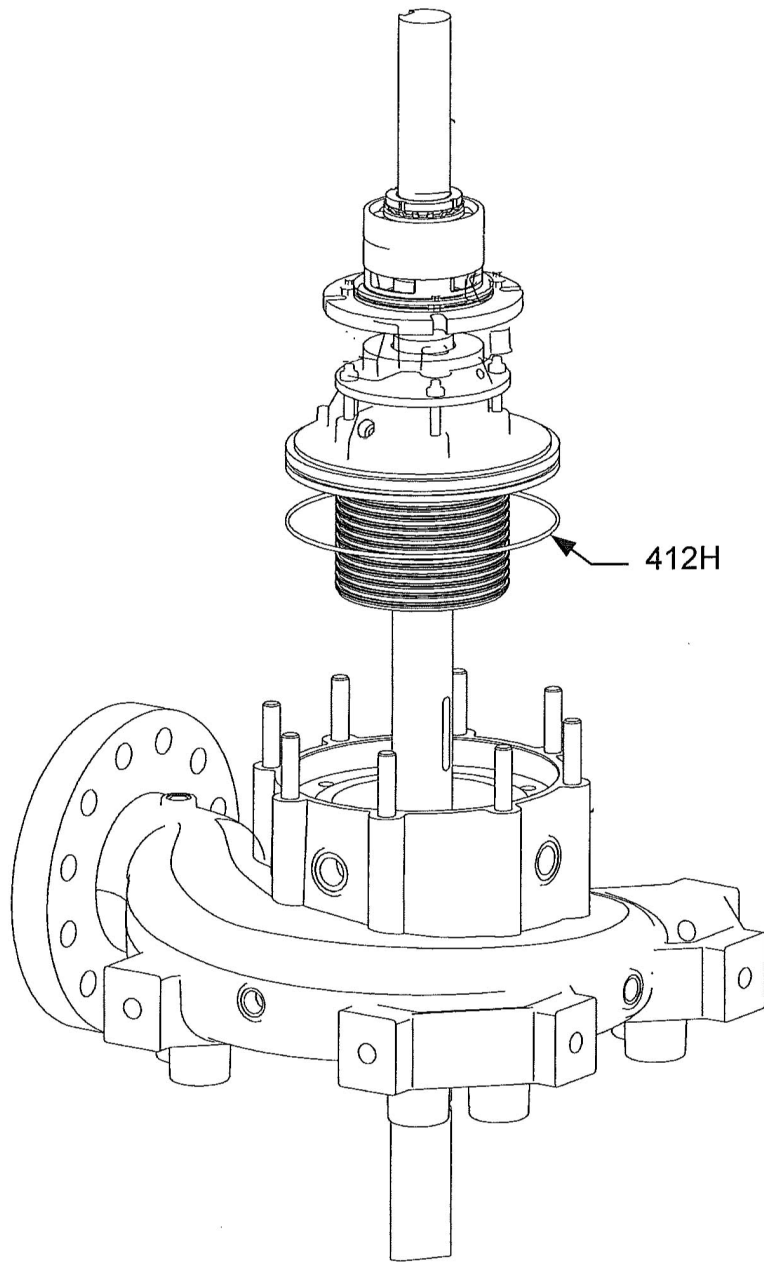

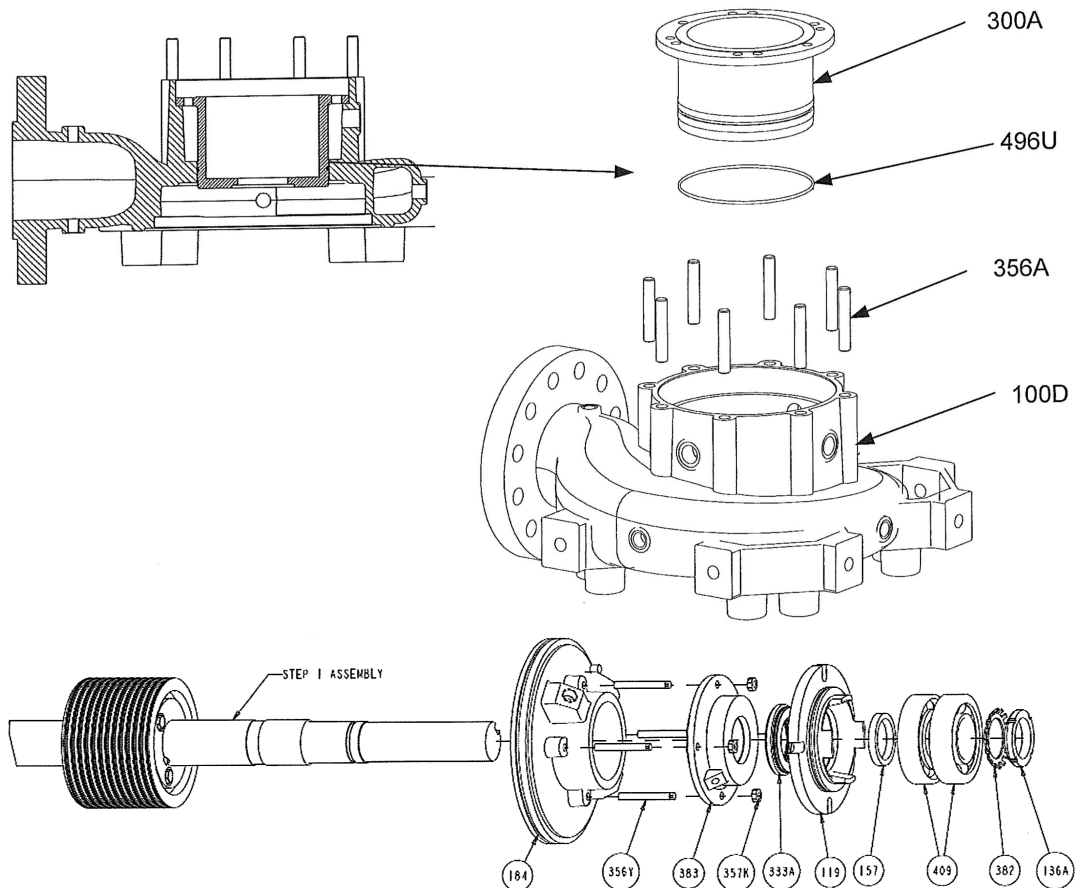

Assembly of complete pump

End and radial suction configuration common assembly procedures

See "End Suction Configuration" or "Radial Suction Configuration" below for steps specific to end or radial suction configuration.

See **Appendix B** for running clearances

See relevant sectional drawing.

If the whole pump is to be assembled, it should be assembled in a vertical position. Start with the discharge casing facing down so that the side that mounts against the bearing housing is facing up. It is important that the pump be secured, stable and supported during assembly. A workbench with a hole (approximately W' larger than the shaft) is very helpful in such cases. A hoist or a second person is required for safe assembly.



WARNING: Make sure that the unit cannot roll or fall over and injure people or damage property.

NOTICE:

- Take care not to damage the shaft (122) during reassembly.
- Final stage diffuser is machined differently to fit into the discharge casing
- First stage impeller may be different than remaining impellers
- Any trimmed impellers are to be located at the discharge end of the pump
- Ensure suction and discharge casings are in the proper orientation
- Follow torqueing instructions and sequence and assembly checks in Appendix D.

1. Place balance drum stator (300A) and balance drum stator o-ring (496U) in the discharge casing.
2. Replace balance drum rotor (300) and balance drum rotor o-ring (412X) on the shaft. Balance drum rotor must be rotated approximately 30 degrees to lock it into place on the shaft. Use the alignment marks placed during disassembly as a guide. Make sure that shaft is braced to prevent it from rotating.
3. Insert balance drum locking plate key (178R) in shaft and slide balance drum locking plate (519) over key and secure it to balance drum with cap screws (372H).
4. Locate shaft approximately in the center of the discharge casing with the coupling end up.
5. Replace seal chamber (184) by inserting the lip on the flat surface of the seal chamber into the positioning hole in the balance drum stator.
6. Replace mechanical seal and gland as noted in instructions for assembly of mechanical seal.
7. Clean and lubricate the fitting surfaces between the bearing housing (228C) and discharge casing (110D).
8. Position the bearing cover (119) with the bearing isolator (333A) over the shaft.
9. Verify that the bearing spacer (157) is in place against the shaft shoulder.

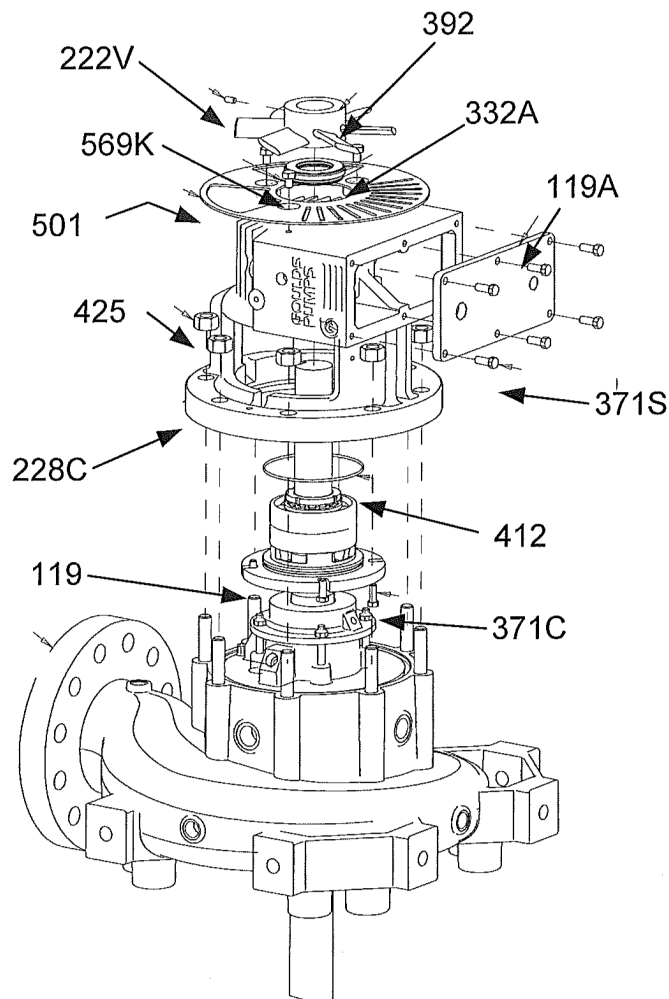

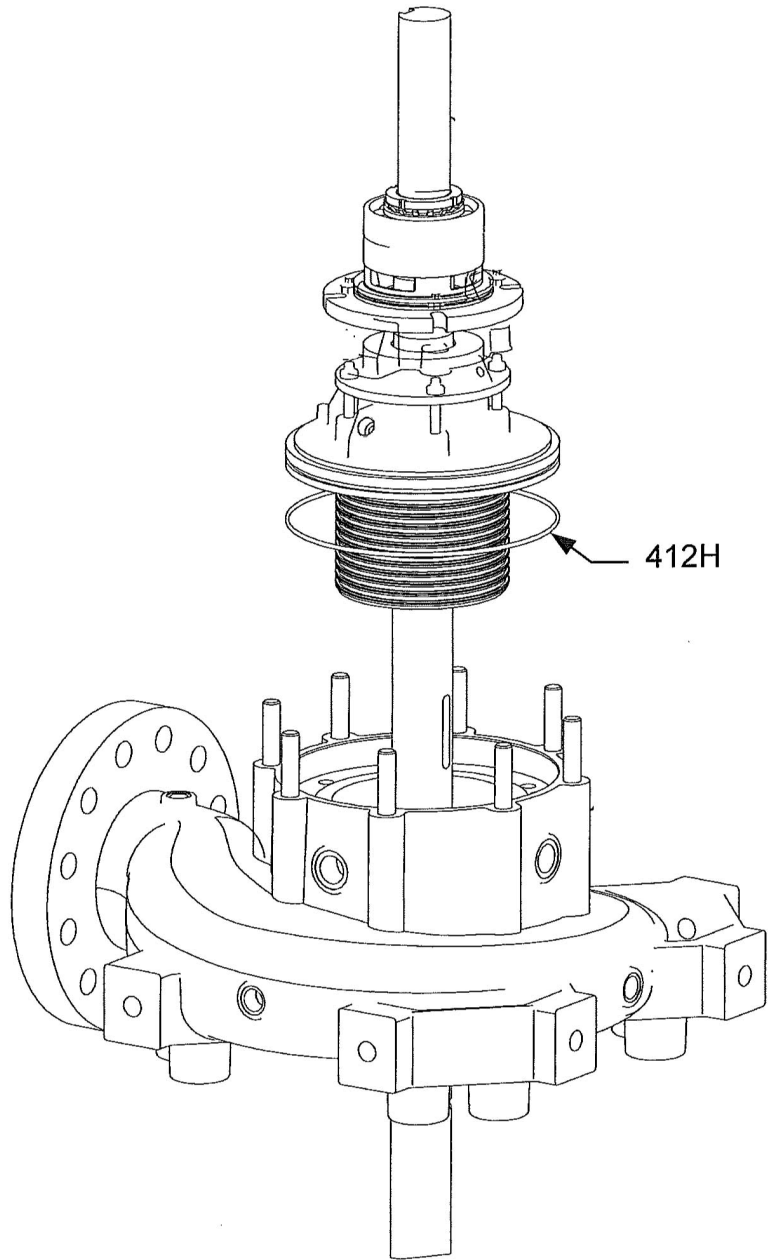

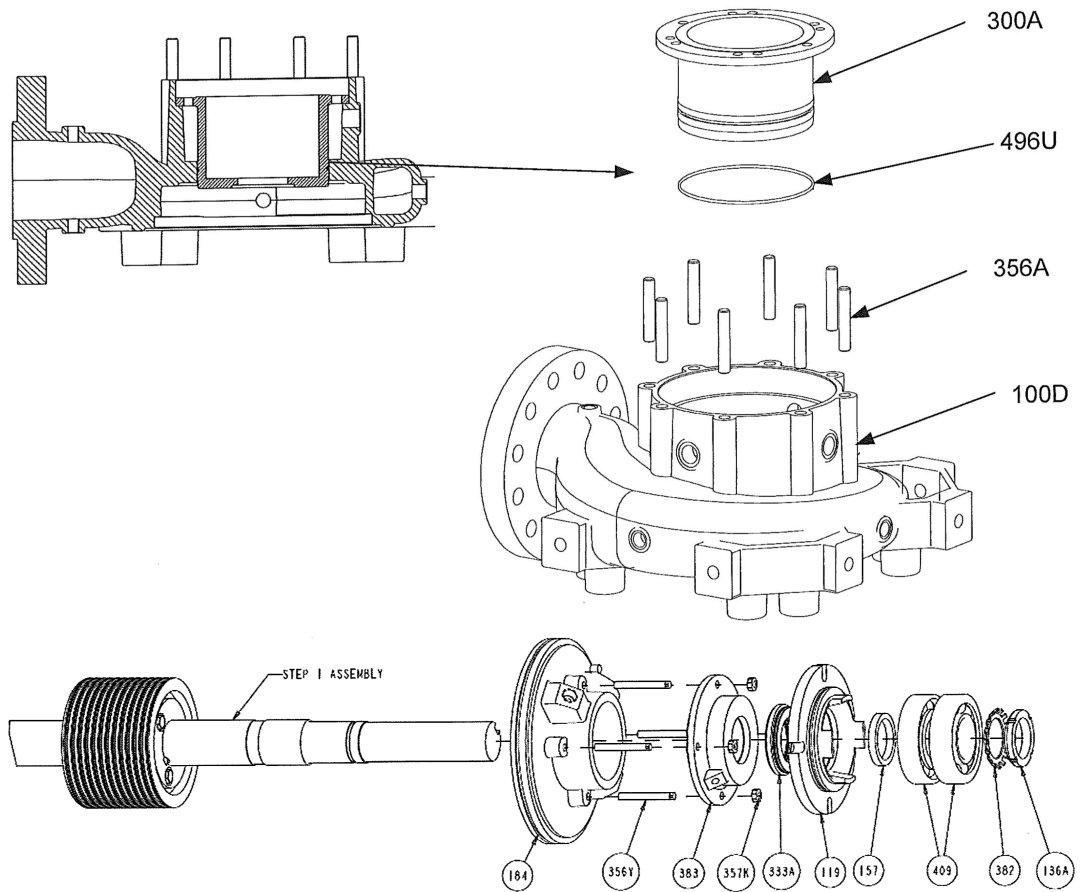

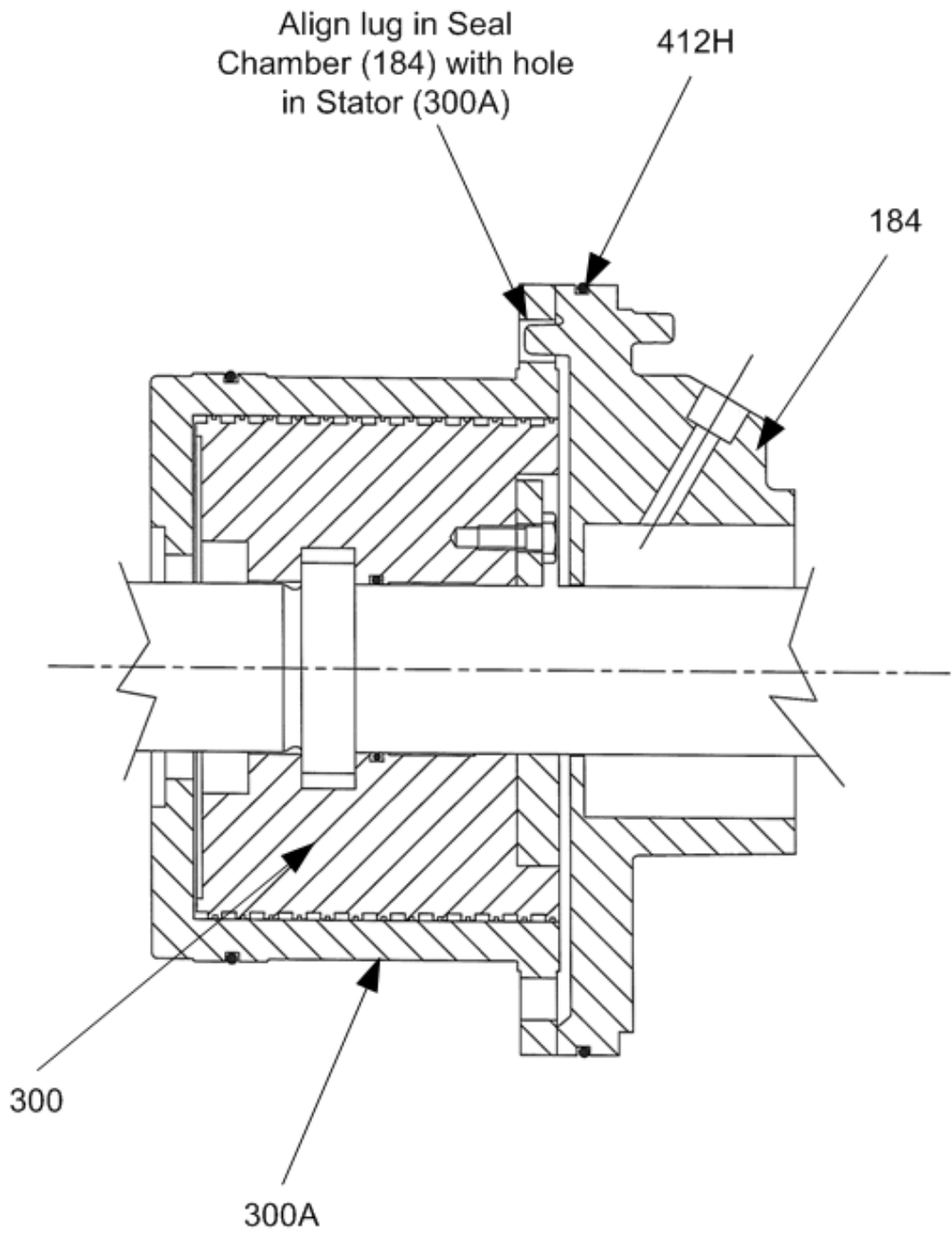

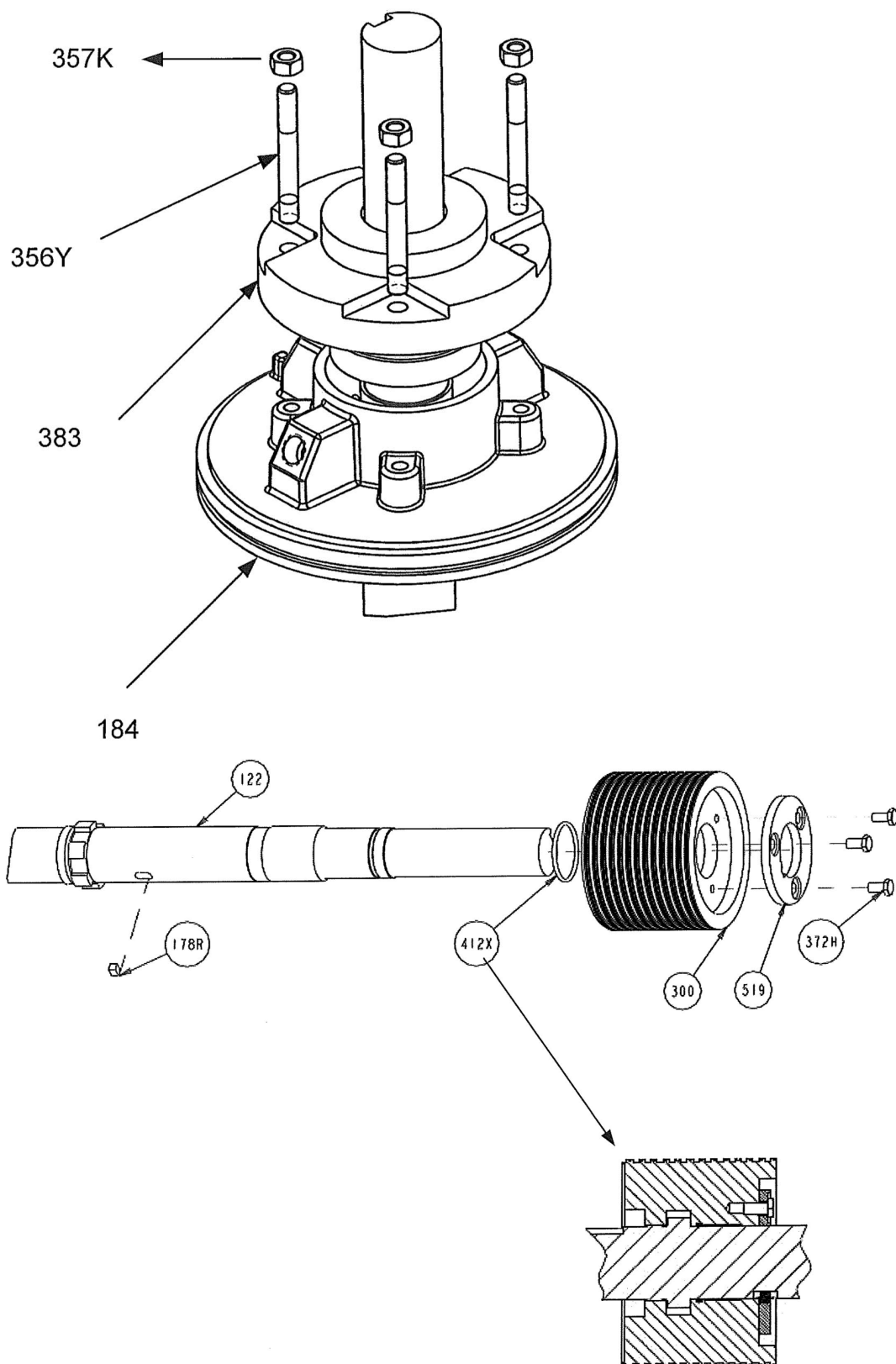

10. Preheat the new bearing (409) (max. 230°F) and slide onto the shaft (122) in a back to back arrangement.
11. Replace bearing lock washer (382) and bearing nut (136A).
12. Allow the bearings (409) to cool to room temperature.

13. Tighten the bearing locknut (136A) until resistance is felt when rotating the bearing outer races in opposite directions by hand. See illustration.
14. Replace the bearing bracket (228C) and align with the shaft (122) and seal chamber (184).
15. Reinstall and tighten nuts (425) to proper torque values.
16. Position bearing housing o-ring (412) and reinstall bearing housing cover (119) with cap screws (371C) and tighten to correct torque values.
The drain hole in the isolator must be at bottom dead center when the pump is in the horizontal position. Use Loctite® thread sealant 5699 or equal when installing the cap screws.
17. Replace cooling fan (392) if applicable.
18. Refit the seal guards.
19. Rotate shaft (122) to see that it turns smoothly.
20. Reorient the assembly 180° so that the discharge casing is down and the shaft extends up.
21. Install last stage impeller (101) and key (178) into discharge casing (100D). Any impeller wear rings should have been installed first.
22. Install final stage piece (100H) and discharge casing o-ring (497D) and secure against discharge casing. Casing and stage piece wear rings should be installed prior to this step
23. Install remaining impellers (101), impeller keys (178), stage casings (100G) and stage casing o-rings (412K). Impellers should all butt up against one another.

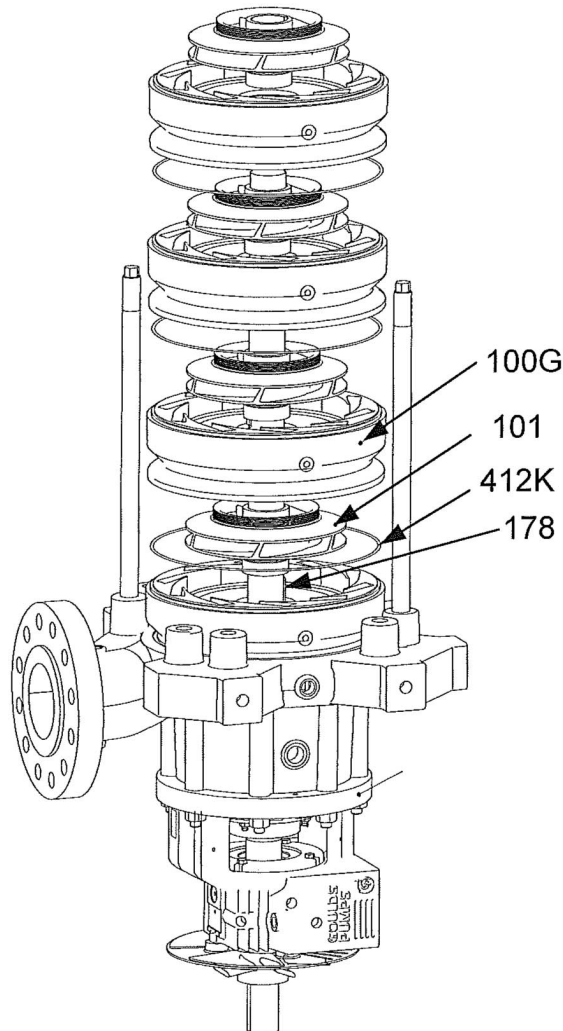

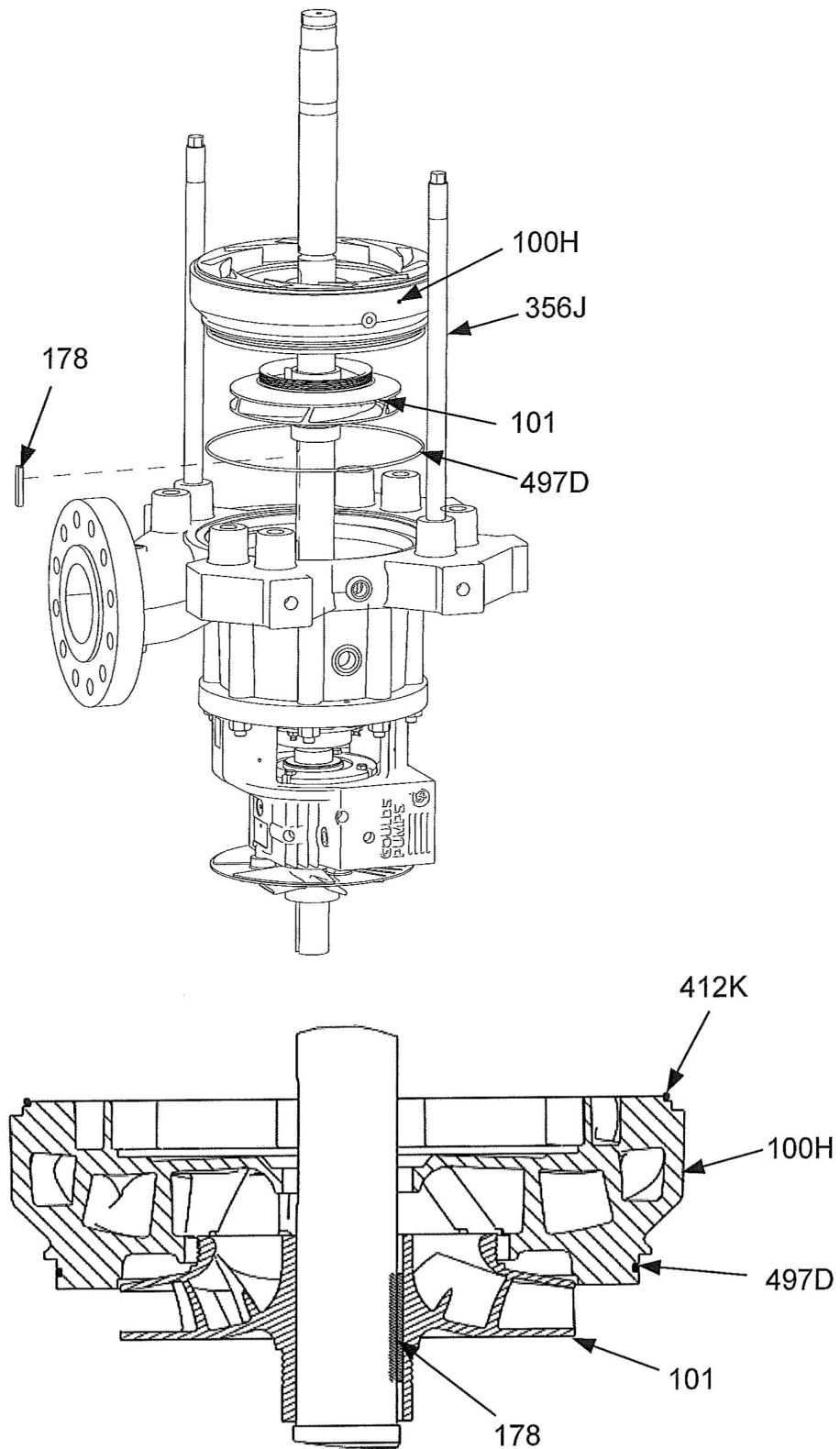

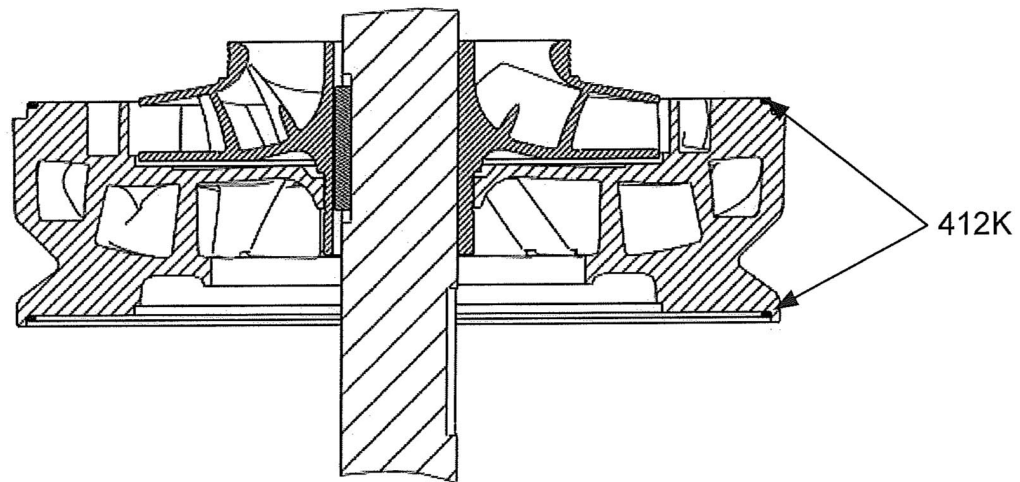

End Suction Configuration

First, complete the steps in "End and radial suction configuration common assembly procedures" before completing the steps below.

1. Clean the fitting surfaces between the bearing sleeve (197A) and suction casing (100S).
2. Coat the casing bearing bore and the outside of the stationary bearing (197A) with Loctite 635.
3. Insert bearing sleeve (197A) and tolerance ring (505D) into the casing sleeve retainer. Use care. This can be facilitated by placing the bearing sleeve in a freezer for approximately one hour and heating the suction casing with hot water. When the casing has been heated, insert the bearing sleeve into the casing bore. The greater the temperature difference between the bore and the sleeve, the easier it will be to insert the bearing sleeve. An assembly fixture that can aid in this portion of the assembly can be made or can be purchased from Goulds.
4. Replace tolerance rings (505D) and sleeve bearing (117) on the end of the shaft.
5. Replace cap screw (469Y) and retaining plate (467) on end of shaft.
6. Replace suction casing (100S) and align with shaft.
7. Install tie rods through the tie rod holes in the suction casing and secure them to the discharge casing by threading them into the casing using the flats on the tie rods to screw them into the discharge casing or by using the tie rod nuts (357F) and tie rod washers (437A).
8. Install tie rod nuts (357F) and tie rod washers (437A) on tie rods and tighten to correct torque values.
See Appendix A for correct torque values and Appendix D for correct torquing sequence.
9. Slide seal and gland into position over seal chamber studs (356Y) and install and tighten seal chamber nuts (357K).
10. Remove setting clips and retain for future use.
11. Spin shaft by hand to check for any binding or other potential problems.
12. Install flush piping to seal gland.

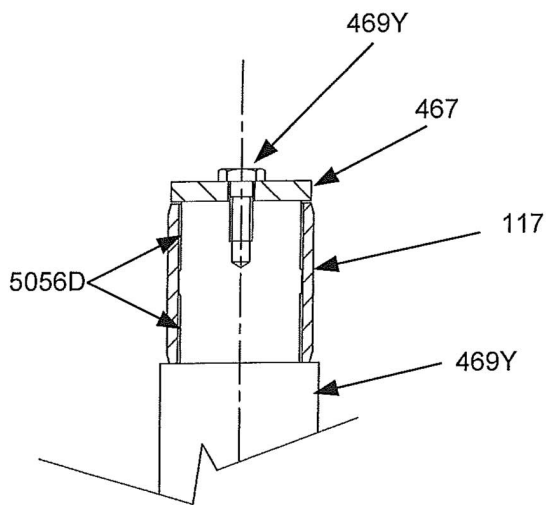
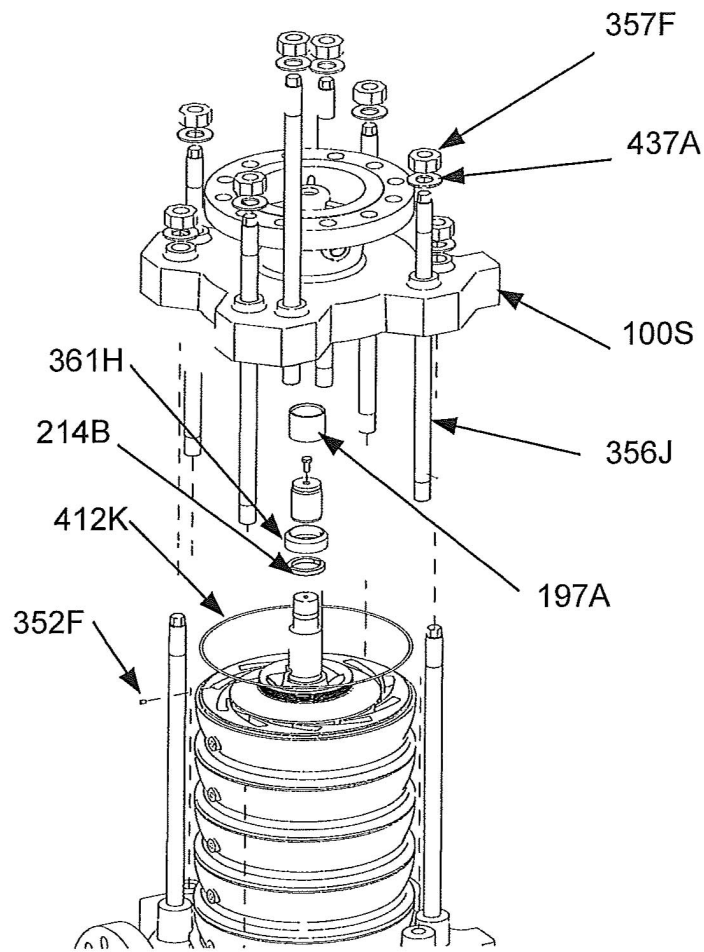

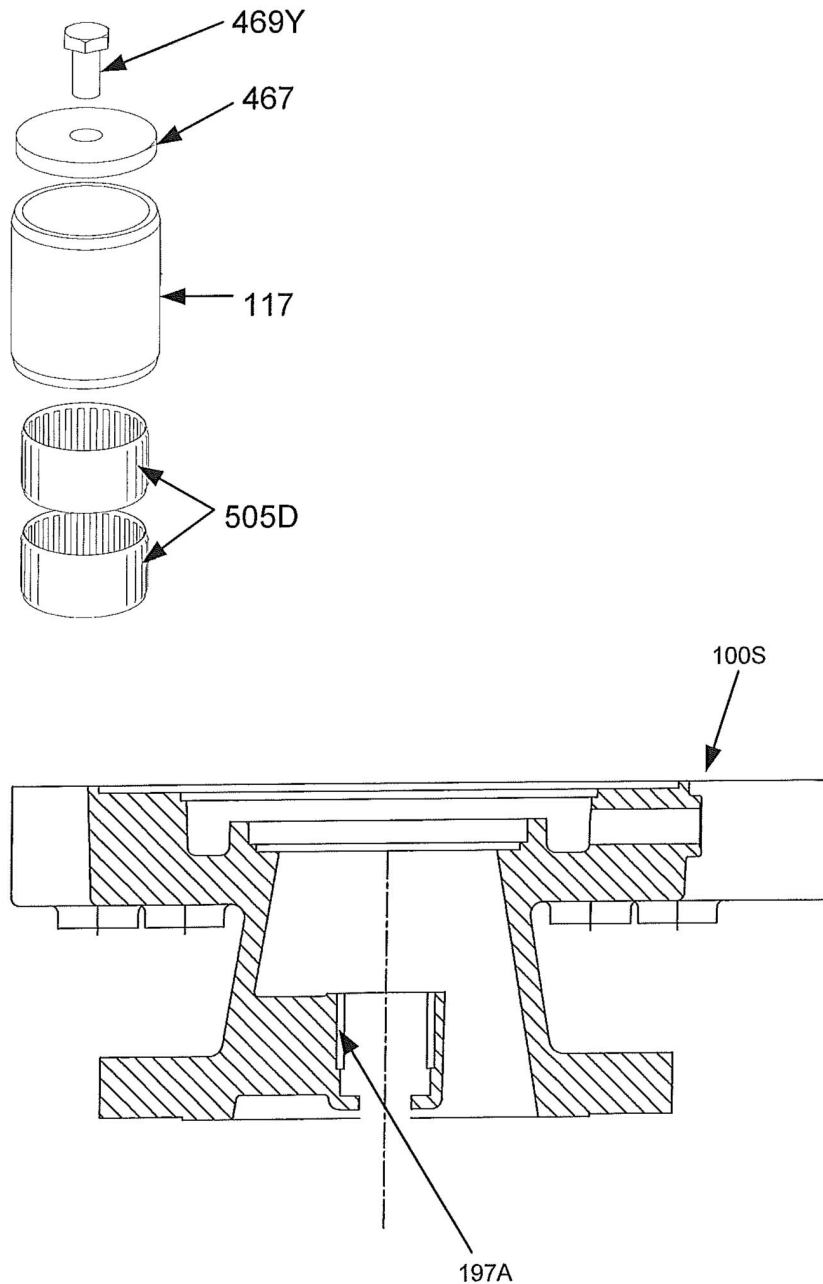

Radial Suction Configuration

First, complete the steps in "End and radial suction configuration common assembly procedures" before completing the steps below.

1. Replace suction casing (100S) and align with shaft.
2. Install tie rods through the tie rod holes in the suction casing and secure them to the discharge casing by threading them into the casing using the flats on the tie rods to screw them into the discharge casing or by using the tie rod nuts (357F) and tie rod washers (437A).
3. Install tie rod nuts (357F) and tie rod washers (437A) on tie rods and tighten to correct torque values.
See Appendix A for correct torque values and Appendix D for correct torquing sequence.
4. Install seal chamber studs (356Y) in radial suction casing.
5. Replace mechanical seal and gland as noted in instructions for assembly of mechanical seal.

-
6. Preheat the new bearing (112) (max. 230°F) and slide onto the shaft (122). Make sure bearing housing cover (119), inboard bearing isolator (333A) and bearing housing cover o-ring (412) are in place on the shaft before installing the bearing.
 7. Install bearing nut (136A).
 8. Install the bearing bracket (228C) and align with the shaft (122) and radial suction casing (100S)
 9. Install bearing housing to casing studs (356J) and tighten nuts (425) to proper torque values.
 10. Position bearing housing o-ring (412) and install bearing housing cover (119) using cap screws (371C).
 11. Replace mechanical seal and gland as noted in instructions for assembly of mechanical seal.
 12. Slide suction side mechanical seal (383) over shaft end and over the seal chamber studs. Install seal chamber nuts (357K) and tighten.
 13. Slide discharge side mechanical seal (383) over shaft end and over the seal chamber studs. Install seal chamber nuts (357K) and tighten.
 14. Remove setting clips on both seals and retain for future use.
 15. Spin shaft by hand to check for any binding or other potential problems.
 16. Connect flush piping to glands.

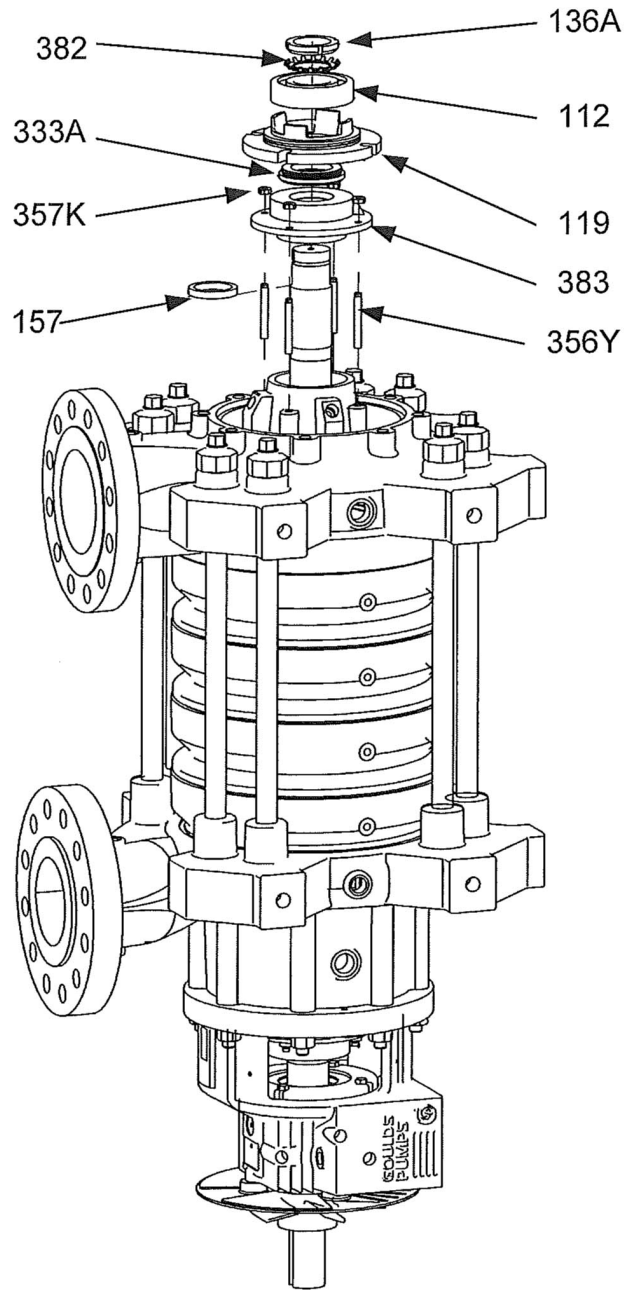

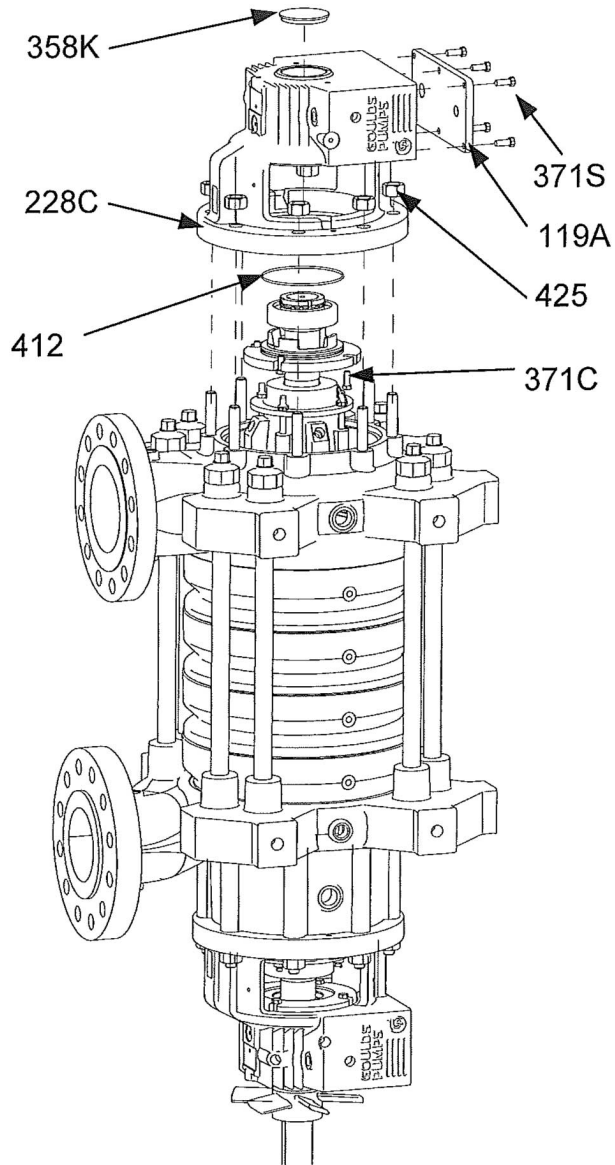

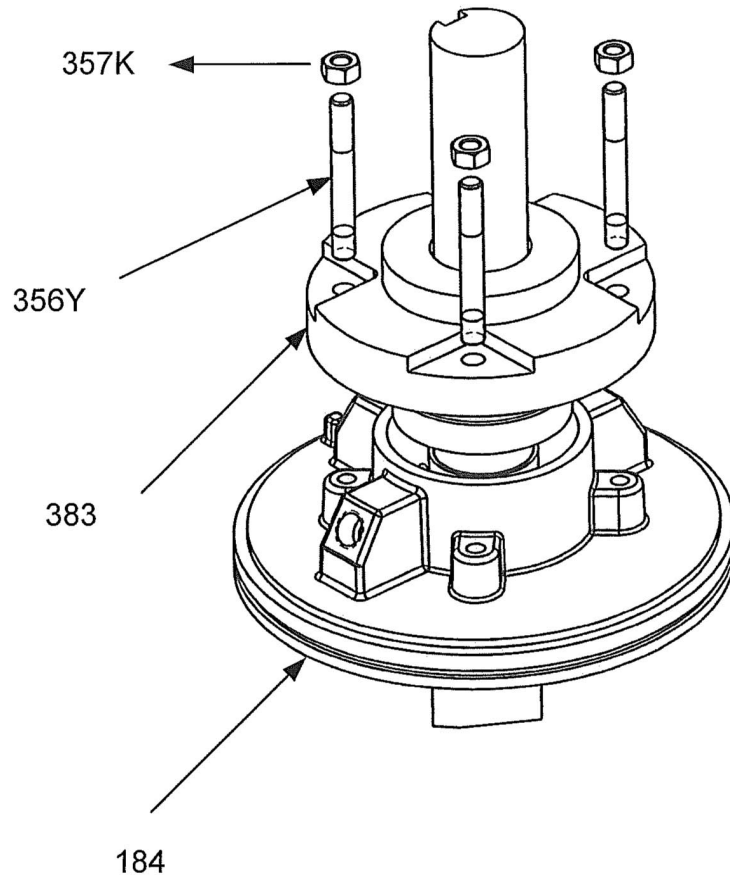

Attach the i-ALERT™ Condition Monitor to the pump



CAUTION:

Always wear protective gloves. The pump and condition monitor can be hot.

Tools required:

- 5/32 inch hex wrench

1. Attach the condition monitor (761B) to the bearing frame (228A) using the hex-head screw (372T) provided.

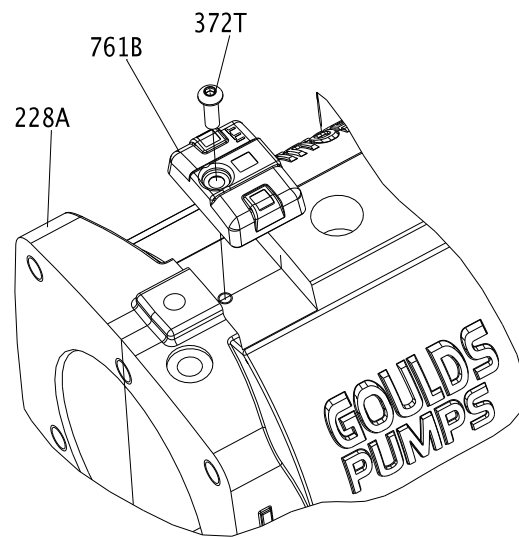

2. Tighten the hex-head screw with a 5/32 inch hex wrench to 6 ft-lbs (8 Nm).

Troubleshooting

Alignment troubleshooting

Symptom	Cause	Remedy
Horizontal (side-to-side) alignment cannot be obtained (angular or parallel).	The driver feet are bolt-bound.	Loosen the pump's hold-down bolts, and slide the pump and driver until you achieve horizontal alignment.
	The baseplate is not leveled properly and is probably twisted.	<ol style="list-style-type: none"> 1. Determine which corners of the baseplate are high or low. 2. Remove or add shims at the appropriate corners. 3. Realign the pump and driver.

i-ALERT™ Condition Monitor troubleshooting

Symptom	Cause	Remedy
There are no green or red flashing LEDs.	The battery is dead.	Replace the condition monitor.
	The unit is deactivated.	Activate the condition monitor.
	The unit is malfunctioning.	Consult your ITT representative for a warranty replacement.
The red LEDs are flashing, but the temperature and vibration are at acceptable levels.	The baseline is bad.	Check the temperature and vibration levels and reset the condition monitor.
	The unit is malfunctioning.	Consult your ITT representative for a warranty replacement.

Operation troubleshooting

Symptom	Cause	Remedy
The flow rate is too low.	The back pressure is too high.	Open the discharge valve a little further.
		Reduce the resistance in the discharge pipe. Clean the filter if necessary.
		Use a larger impeller. Make sure to take note of the available motor power.
	The speed is too low.	Increase the speed. Check the available motor power.
		Compare the speed of the motor with the specified pump speed. See the rating place.
		When you adjust the speed (frequency transformer), check the reference value settings.
	The impeller diameter is too small.	Use a larger impeller. Check the available motor power.
	The pump and/or pipes are not completely filled with liquid.	Fill the pump and/or pipes with liquid.
		Vent the pump and/or pipes.
	The pump or suction/intake pipe is blocked.	Clean the pipes.
	There is an air pocket in the pipeline.	Vent the pipes.
		Improve the pathway of the pipes.
	The NPSH is too low.	Increase the liquid level.
Increase the suction pressure.		
Reduce the resistance in the intake/suction pipe. Change the course and pipe size, open the shutoff valves, and clean the filters.		
Air is being sucked into the pipes.	Increase the liquid level.	
	Check that the suction pipe is vacuum-tight.	
	Provide valves and fittings in the suction pipe with water seal.	
The direction of rotation is wrong.	Change the motor rotation.	
The inner components are suffering from wear.	Replace the worn parts.	
Density and/or viscosity of the pumped liquid is too high.	Seek assistance	
The flow rate stops after a period of time.	The pump or suction/intake pipe is blocked.	Clean the pipes.
	The NPSH is too low.	Increase the liquid level.
		Increase the suction pressure.
		Reduce the resistance in the intake/suction pipe. Change the course and pipe size, open the shutoff valves, and clean the filters.
	Air is being sucked into the pipes.	Increase the liquid level.
		Check that the suction pipe is vacuum-tight.
Provide valves and fittings in the suction pipe with water seal.		
The inner components are suffering from wear.	Replace any worn parts.	
The density and/or viscosity of the pumped liquid is too high.	Seek assistance.	

Symptom	Cause	Remedy
The head is too low.	The back pressure and discharge pressure are too low.	Throttle the discharge valve.
	The speed is too low.	Increase the speed. Check the available motor power.
		Compare the speed of the motor with the specified pump speed. See the rating plate.
		When you adjust the speed (frequency transformer), check the reference value settings.
	The impeller diameter is too small.	Use a larger impeller. Make sure to check the available motor power.
	The pump and/or pipes are not completely filled with liquid.	Fill the pump and/or pipes with liquid.
		Vent the pump and/or pipes.
	The pump or suction/intake pipe are blocked.	Clean the pipes.
	There is an air pocked in the pipeline.	Vent the pipeline.
		Improve the path of the pipes.
	The NPSH of the system is too low.	Increase the liquid level.
		Increase the suction pressure.
		Reduce the resistance in the intake/suction pipe. Change the course and pipe size, open the shutoff valves, and clean the filters.
Air is being sucked into the pipes.	Increase the liquid level.	
	Check that the suction pipe is vacuum-tight.	
	Provide valves and fittings in the suction pipe with water seal.	
The direction of rotation is wrong.	Change the motor rotation.	
The inner components are suffering from wear.	Replace the worn parts.	
The density and/or viscosity of the pumped liquid is too high.	Seek assistance.	
The head is too high.	The speed is too high.	Reduce the speed.
		Compare the speed of the motor with the specified pump speed. See the rating plate.
		When you adjust the speed (frequency transformer), check the reference value setting.
	The impeller diameter is too large.	Use a smaller impeller.

Symptom	Cause	Remedy
The drive mechanism is overloaded	The back pressure and discharge pressure are too low.	Throttle the discharge valve.
	The speed is too high.	Reduce the speed.
		Compare the speed of the motor with the specified pump speed. See the rating plate.
		When you adjust the speed (frequency transformer), check the reference value setting.
	The impeller diameter is too large.	Use a smaller impeller.
	The density and/or viscosity of the pumped liquid is too high.	Seek assistance.
	The shaft seal is worn.	Replace the mechanical seal.
		Check the sealing, flushing, and cooling pipe (pressure).
		Avoid running the pump dry.
There is not enough sealing.	Tighten the screws. Replace the mechanical seal.	
The discharge pressure is too low.	Increase the minimum amount being carried. Open the control valves and bypass piping.	
There is not enough hydraulic thrust balance.	Clean the relief holes in the impeller.	
	Replace the worn impeller and wear rings.	
The pump is not running quietly.	The pump and/or pipes are not completely filled with liquid.	Fill with liquid
		Vent the pump and/or pipes.
	The NPSH is too low.	Increase the liquid level.
		Increase the suction pressure.
		Reduce the resistance in the intake/suction pipe. Change the course and pipe size, open the shutoff valves, and clean the filters.
	The inner components are suffering from wear.	Replace the worn parts.
	Forces in the pipeline are too high and the pump is under strain.	Change the position of the support pipes and use compensators.
		Check that the foundation plate and frame are properly cast and in place.
	There is too much, not enough, or the wrong type of lubricant.	Change the lubricant.
	The electrical supply is incorrect.	Check the voltage of all phases (2-phase running).
		Check the cable connections.
Check the fuses.		
The sealing is insufficient.	Tighten the screws.	
	Replace the mechanical seal.	
There is not enough hydraulic thrust balance.	Clean the relief holes in the impeller. Replace the worn impeller and wear rings.	
There is system-related vibration (resonance).	Seek assistance.	
The pump casing becomes warm during operation.	The pump or suction/intake pipe is blocked	Clean the pump and pipes.
	The NPSH is too low.	Increase the liquid level.
		Increase the suction pressure.
		Reduce the resistance in the intake/suction pipe. Change the path and pipe size, open the shutoff valves, and clean the filters.
	The inner components are suffering from wear.	Replace the worn parts.
There is system-related vibration (resonance).	Seek assistance.	

Symptom	Cause	Remedy
The temperature in the shaft sealing area is too high.	The shaft seal is worn.	Replace the mechanical seal. Check the sealing, flushing, and cooling pipe (pressure). Do not run the pump dry.
	There are lines and rough spots on the shaft or shaft sleeve.	Replace the worn parts.
	There are deposits on the mechanical seal.	Clean the mechanical seal. Replace the mechanical seal if necessary. Provide additional rinsing or quench.
	The coupling is not aligned.	Align the pump.
The temperature at the bearing is too high.	The back pressure is too high.	Open the discharge valve more. Reduce resistance in the discharge pipe. Clean the filter if necessary. Use a larger impeller. Make sure to note the available motor power.
	The back pressure and the discharge pressure are too low.	Throttle the discharge valve.
	The speed is too high.	Reduce the speed. Compare the speed of the motor with the specified pump speed. See the rating plate. When you adjust the speed (frequency transformer), check the reference value setting.
	The inner components are suffering from wear.	Replace the worn parts.
	The forces in the pipeline are too high and the pump is under strain.	Change the position of the support pipes and use compensators. Check that the foundation plate and frame are properly cast and in place.
	There is either too much, too little, or the wrong type of lubricant.	Change the lubricant.
	The electrical supply is not correct.	Check the voltage of all phases (2-phase running). Check the cable connections. Check the fuses.
	There is not enough sealing.	Tighten the screws. Replace the mechanical seal.
	The bearing is damaged.	Replace the bearing. Check the lubricant and bearing space for pollutants. Rinse the oil area.
	There is not enough hydraulic thrust balance.	Clean the relief holes in the impeller. Replace the worn impeller and wear rings.
	There is system-related vibration (resonance).	Seek assistance.
	The pump is leaking.	There is not enough sealing.
The discharge pressure is too high.		Reduce the amount of pressure that is carried. Throttle the control valve.

Symptom	Cause	Remedy
There are leaks at the shaft seal.	The shaft seal is worn.	Replace the mechanical seal.
		Check the sealing, flushing, and cooling pipes (pressure).
		Do not run the pump dry.
	There are deposits on the mechanical seal.	Clean the mechanical seal.
		Replace the mechanical seal if necessary.
		Provide additional rinsing or quench if necessary.
	The impeller is out of balance.	Remove any blocks or deposits.
		Replace the impeller if it is broken or unevenly worn.
		Check the shafts to make sure that they are running true.
	The coupling is not aligned.	Align the pump.
The coupling distance is too small.	Correct this.	
Forces in the pipeline are too high and the pump unit is under strain.	Change the position of the support pipes and use compensators.	
	Check that the foundation plate and frame are properly cast and in place.	
There is not enough sealing.	Tighten the screws.	
	Replace the mechanical seal.	

Parts Listings and Cross-Sectionals

Parts

Cross-Sectional Drawings - End Suction

ITEM	COMPONENT	QTY.
100D	CASING (DISCHARGE)	1
100G	CASING (STAGE)	1
100H	CASING (FINAL STAGE)	1
100S	CASING (SUCTION)	1
101	IMPELLER	1
103	CASE WEAR RING	1
* 113A	BREATHER	1
117	BEARING SLEEVE	1
119	COVER (BEARING HOUSING)	1
119A	COVER (BEARING HOUSING SUMP)	1
122	SHAFT	1
131	PUMP FOOT	2
136A	BEARING NUT	1
142	IMPELLER WEAR RING (OPTIONAL)	1
178	KEY (IMPELLER)	1
178R	KEY (BALANCE DRUM)	1
184	SEAL CHAMBER	1
197A	BEARING BUSHING	1
214B	SPLIT RING	1
222V	SET SCREW (FAN) (Ø)	1
228C	BEARING HOUSING	1
251	OILER (CONSTANT LEVEL)	1
300	BALANCE DRUM	1
300A	BALANCE DRUM STATOR	1
301	IMPELLER (SUCTION) (OPTIONAL)	1
332A	BEARING ISOLATOR (OUTBOARD)	1
332A	BEARING ISOLATOR (INBOARD)	2
352F	SET SCREW (RETAINING RING)	1
356A	STUD (BEARING HOUSING TO CASING)	18
356J	TIE ROD	8
356Y	STUD (SEAL CHAMBER)	8
357F	NUT (TIE ROD)	8
357K	NUT (SEAL CHAMBER)	8
358	DRAIN PLUG (CASING)	3
358L	PLUG (BALANCE RETURN)	4
358M	PLUG (CASING BRANCH TAPPING)	4
381H	RETAINING RING	1
371C	CAP SCREW (BEARING HOUSING CVR)	8

ITEM	COMPONENT	QTY.
371S	CAP SCREW (BEARING HOUSING SUMP COVER)	12
372H	CAP SCREW (BALANCE DRUM LOCKING PLATE)	3
372T	CAP SCREW (I-ALERT TO BEARING HOUSING)	1
383	MECHANICAL SEAL	1
392	FAN (BEARING COOLING) (Ø)	1
400	KEY (COUPLING)	1
408A	PLUG (BEARING HOUSING DRAIN)	2
* 408J	PLUG (BEARING HOUSING OILER)	2
* 408K	PLUG (BEARING HOUSING BREATHER)	2
408R	PLUG (SUMP TEMPERATURE SENSOR)	2
* 408S	PLUG (BEARING TEMPERATURE SENSOR)	4
* 409	BALL BEARING THRUST	2
412	O RING (BEARING HOUSING COVER)	2
412H	O RING (SEAL CHAMBER)	1
412K	O RING (STAGE CASING)	1
412X	O RING (BALANCE DRUM)	1
418	CAP SCREW (BEARING HOUSING JACKING)	4
* 424	SCREW (PLATE TO CASING/FRAME)	12
425	NUT (BEARING HOUSING TO PUMP CASING)	16
437A	WASHER (TIE ROD)	8
437H	O RING (BEARING BUSHING)	1
437K	O RING (SHAFT CASING)	1
489Y	CAP SCREW (RETAINING PLATE TO SHAFT)	1
496U	O RING (BALANCE DRUM STATOR)	1
497D	O RING (DISCHARGE CASING)	1
* 498	GUARD (SHAFT SEAL)	2
505D	TOLERANCE RING (BEARING SLEEVE)	2
519	LOCKING PLATE (BALANCE DRUM)	1
* 543	BOLT RETAINER (GUARD TO BEARING HOUSING)	8
* 543	NAMEPLATE (CASING)	1
* 543C	WARNING PLATE	1
* 549D	WARNING LABEL (COUPLING GUARD, PACKAGED)	1
* 549E	WARNING LABEL (FRAME)	1
* 549U	WARNING TAG (COUPLING GUARD, BARE PUMP)	1
* 589F	CAP SCREW (GUARD TO BEARING HOUSING)	8
761B	I-ALERT CONDITION MONITOR	1
* 772C	WARNING TAG (LIFTING)	1

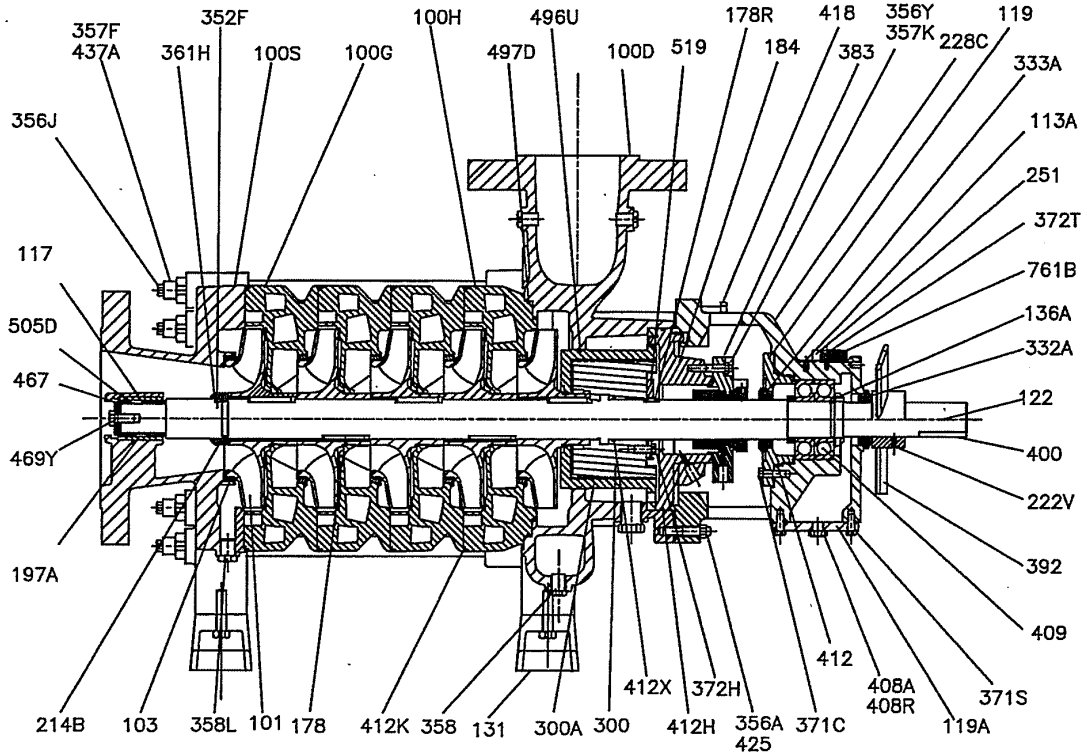

Cross-Sectional Drawings – Radial Suction

ITEM	COMPONENT	QTY.
100D	CASING (DISCHARGE)	1
100G	CASING (STAGE)	1
100H	CASING (FINAL STAGE)	1
100S	CASING (SUCTION)	1
101	IMPELLER	1
103	CASE WEAR RING	1
112	BALL BEARING (RADIAL)	1
* 113A	BREATHER	2
119	COVER (BEARING HOUSING)	2
119A	COVER (BEARING HOUSING SUMP)	2
122	SHAFT	1
131	PISTON PUMP	2
136A	BEARING NUT	2
142	IMPELLER WEAR RING (OPTIONAL)	1
157	SPACER SLEEVE	2
178	KEY (IMPELLER)	1
178K	KEY (BALANCE DRUM)	1
184	SEAL CHAMBER	8
214B	SPLIT RING	1
222V	SET SCREW (FAN O)	1
228C	BEARING HOUSING	2
251	DILER (CONSTANT LEVEL)	2
300	BALANCE DRUM	2
300A	BALANCE DRUM STATOR	1
301	IMPELLER (SUCTION) (OPTIONAL)	1
332	BEARING ISOLATOR (OUTBOARD)	1
333A	BEARING ISOLATOR (INBOARD)	2
352F	SET SCREW (RETAINING RING)	1
356A	STUD (BEARING HOUSING TO CASING)	16
356V	TIE ROD	8
357	STUD (SEAL CHAMBER)	8
357K	NUT (TIE ROD)	8
357K	NUT (SEAL CHAMBER)	8
358	BRAD NUT (CASING)	2
358A	PLUG (SEAL CHAMBER FLUSH)	2
358K	PLUG (BEARING HOUSING OPENING)	1
358L	PLUG (BALANCE RETURN)	4
358M	PLUG (CASING BRANCH TAPPING)	4

ITEM	COMPONENT	QTY.
361H	RETAINING RING	1
371C	CAP SCREW (BEARING HOUSING COVER)	8
371S	CAP SCREW (BEARING HOUSING SUMP COVER)	12
372H	CAP SCREW (BALANCE DRUM LOCKING PLATE)	3
372T	CAP SCREW (G-ALERT TO BEARING HOUSING)	2
382	LOCK WASHER (THRUST RADIAL BEARING)	2
383	MECHANICAL SEAL	1
392	FAN (BEARING COOLING) (O)	1
400	KEY (COUPLING)	1
408A	PLUG (BEARING HOUSING DRAIN)	2
* 408J	PLUG (BEARING HOUSING DILER)	2
* 408K	PLUG (BEARING HOUSING BREATHER)	2
* 408R	PLUG (SUMP TEMPERATURE SENSOR)	2
* 408S	PLUG (BEARING TEMPERATURE SENSOR)	4
* 409	BALL BEARING (THRUST)	2
412	O RING (BEARING HOUSING COVER)	2
412H	O RING (SEAL CHAMBER)	1
412K	O RING (CASING)	1
412X	O RING (BALANCE DRUM)	1
* 418	CAP SCREW (BEARING HOUSING JACKING)	4
* 424	SCREW PLATE (TO CASING/FRAME)	12
425	NUT (BEARING HOUSING TO PUMP CASING)	16
* 457A	WASHER (TIE BOLT)	8
496U	O RING (BALANCE DRUM STATOR)	1
497D	O RING (DISCHARGE CASING)	1
* 499	GUARD (SHAFT SEAL)	1
* 519	LOCKING PLATE (BALANCE DRUM)	1
* 534C	BOLT (RETAINER GUARD TO BEARING HOUSING)	8
* 549	NAMEPLATE (CASING)	1
* 549C	WARNING PLATE	1
* 549D	WARNING LABEL (COUPLING GUARD, PACKAGED PUMP)	1
* 549E	NAMEPLATE (FRAME)	1
* 549I	WARNING TAG (COUPLING GUARD, BARE PUMP)	1
* 559F	CAP SCREW (GUARD TO BEARING HOUSING)	8
* 761B	WATER CONDITION MONITOR	1
* 772F	WARNING TAG (LIFTING)	1

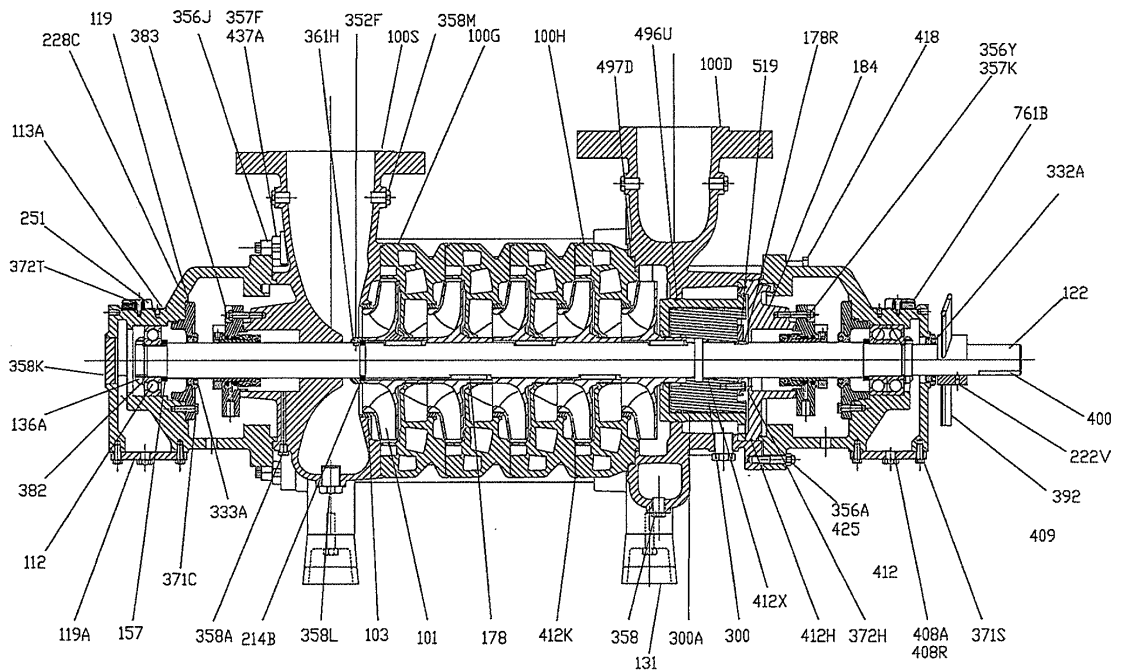

SPARE AND REPAIR PARTS

Spare parts stock should be based on customer's operating experience, risk assessment, cost of downtime and part lead times. In the absence of this information, the following is offered as a guideline. The quantities shown are on a per pump basis. Items with an asterisk should be multiplied by the number of stages. For multiple pump installations, the total quantity can be reduced.

Part Name	Start Up Spares	1 year operation	2 year operation	Export
Mechanical Seal	1	1	1	1
Impeller*	1	1	1	1
Case Wear Ring*	1	1	1	2
Stage Piece*	-	-	(# stages -2) / 3	(# stages -2) / 2
Final Stage Piece	-	-	1	1
Radial Bearing	1	1	1	1
Thrust Bearing	1	1	2	2

Parts Listings and Cross-Sectionals

Balance Drum	1	1	1	1
Sleeve Bearing (ES)	1	1	1	1

Appendix

Torque Values

Appendix A

Item #	Part Description	Fastener Size	Carbon Steel Class 8.8 Torque		Stainless Steel Class 70 Torque		Pump Size			
			ft-lbs	N-m	ft-lbs	N-m	2.5x4-8 2.5x5-8	4x5-10 4x6-10	5x6-11 5x8-11	6x8-13 6x10-13
356A 425	Stud / Nut Bearing Housing to Casings	M16x2	81	110			X	X		
		M20x2.5	163	221					X	
		M24x3	281	381						X
356Y 357K	Stud / Nut Seal Chamber	M8x1			6.6	9	X			
		M12x1.75			24	32		X	X	X
372H	Cap Screw Balance Drum to Locking Plate	M10x1.5			14.0	19	X	X	X	X
371C	Cap Screw Bearing Housing Cover	M10x1.5			14.0	19	X	X		
		M12x1.75			24	32			X	X
371S	Cap Screw Bearing Housing Sump	M10x1.5			14.0	19	X	X		
		M12x1.75			24	32			X	X
469Y	Cap Screw Retaining Plate to Shaft	M10x1.5			14.0	19	X	X	X	X
569F	Cap Screw Guard to Bearing Housing	M6x1			3.0	4	X	X	X	X
136A	Locknut Bearing	M40x1.5	65	88			X			
		M45x1.5	75	101				X		
		M55x2	105	142					X	
		M70x2	175	237						X
356J 357F	Tie-Rod / Tie Rod Nut	20x2.5	163	221			X			
		24x3	281	381				X		
		30x3.5	559	758					X	
		36x4	976	1324						X

Running clearances

Appendix B

Table 7:

	Diametric Clearance	English Units (inches)					Metric Units (mm)				
		2.5x4-8A	2.5x4-8B	4x5-10	5x6-11	6x8-13	2.5x4-8A	2.5x4-8B	4x5-10	5x6-11	6x8-13
Impeller Hub or Wear Ring to Casing Wear Ring Normal Clearance	Normal	0.010	0.011	0.012	0.012	0.012	0.25	0.28	0.30	0.30	0.30
	Replace	0.020	0.022	0.024	0.024	0.024	0.51	0.56	0.60	0.60	0.60

		English Units (inches)					Metric Units (mm)				
Impeller Hub or Wear Ring to Casing Wear Ring Reduced Clearance	Normal	0.007	0.007	0.008	0.008	0.008	0.20	0.20	0.20	0.20	0.20
	Replace	0.014	0.014	0.016	0.016	0.016	0.40	0.40	0.40	0.40	0.40
Impeller Hub to Diffuser	Normal	0.020	0.020	0.020	0.020	0.020	0.51	0.51	0.51	0.51	0.51
	Replace	0.040	0.040	0.040	0.040	0.040	1.02	1.02	1.02	1.02	1.02
Balance Drum to Stator	Normal	0.016	0.016	0.016	0.016	0.016	0.40	0.40	0.40	0.40	0.40
	Replace	0.032	0.032	0.032	0.032	0.032	0.80	0.80	0.80	0.80	0.80
Suction Bearing Bushing to Sleeve (ES)	Normal	0.004	0.004	0.004	0.004	0.004	0.10	0.10	0.10	0.10	0.10
	Replace	0.008	0.008	0.008	0.008	0.008	0.20	0.20	0.20	0.20	0.20

Maximum allowable forces and moments

Appendix C

Table 8: Suction Nozzle Configuration (English units)

		Forces (lbf)				Moments (ft-lbs)			
	Flange Size (in)	Fx	Fy	Fz	Σ F	Mx	My	Mz	Σ M
Horizontal nozzle parallel to the shaft (ES)	5	550	440	360	790	1340	685	1020	1820
	6	700	560	460	1010	1700	870	1300	2310
	8	1100	850	700	1560	2600	1300	1900	3500
	10	1500	1200	1000	2200	3700	1800	2800	5000
Vertical nozzle perpendicular to the shaft (RS)	4	320	260	400	570	980	500	740	1330
	5	440	360	550	790	1340	685	1020	1820
	6	560	460	700	1010	1700	870	1300	2310
	8	850	700	1100	1560	2600	1300	1900	3500
Horizontal nozzle perpendicular to the shaft (RS)	4	320	400	260	570	980	500	740	1330
	5	550	440	360	790	1340	685	1020	1820
	6	560	700	460	1010	1700	870	1300	2310
	8	850	1100	700	1560	2600	1300	1900	3500

Table 9: Suction Nozzle Configuration (Metric units)

		Forces (N)				Moments (Nm)			
	Flange Size (in)	Fx	Fy	Fz	Σ F	Mx	My	Mz	Σ M
Horizontal nozzle parallel to the shaft (ES)	5	2440	1955	1605	3520	1815	930	1380	2465
	6	3110	2490	2050	4480	2300	1180	1760	3130
	8	4890	3780	3110	6920	3530	1760	2580	4710
	10	6670	5340	4450	9630	5020	2440	3800	6750
Vertical nozzle perpendicular to the shaft (RS)	4	1420	1160	1780	2560	1330	680	1000	1800
	5	1955	1605	2445	3520	1815	930	1380	2465
	6	2490	2050	3110	4480	2300	1180	1760	3130
	8	3780	3110	4890	6920	3530	1760	2580	4710
Horizontal nozzle perpendicular to the shaft (RS)	4	1420	1780	1160	2560	1330	680	1000	1800
	5	1955	2445	1605	3520	1815	930	1380	2465
	6	2490	3110	2050	4480	2300	1180	1760	3130
	8	3780	4890	3110	6920	3530	1760	2280	4710

Table 10: Discharge Nozzle Configuration (English units)

		Forces (lbf)				Moments (ft-lbs)			
	Flange Size (in)	Fx	Fy	Fz	Σ F	Mx	My	Mz	Σ M

		Forces (lbf)				Moments (ft-lbs)			
Vertical nozzle perpendicular to the shaft (ES and RS)	2.5	200	165	250	360	520	260	395	705
	4	320	260	400	570	980	500	740	1330
	5	440	360	550	790	1340	685	1020	1820
	6	560	460	700	1010	1700	870	1300	2310
Horizontal nozzle perpendicular to the shaft (ES and RS)	2.5	200	165	250	360	520	260	395	705
	4	320	400	260	570	980	500	740	1330
	5	440	550	360	790	1340	685	1020	1820
	6	560	700	460	1010	1700	870	1300	2310

Table 11: Discharge Nozzle Configuration (Metric units)

		Forces (N)				Moments (Nm)			
	Flange Size (in)	Fx	Fy	Fz	ΣF	Mx	My	Mz	ΣM
Vertical nozzle perpendicular to the shaft (ES and RS)	2.5	890	735	1110	1605	705	350	535	950
	4	1420	1160	1780	2560	1330	680	1000	1800
	5	1955	1605	2445	3520	1815	930	1380	2465
	6	2490	2050	3110	4480	2300	1180	1760	3130
Horizontal nozzle perpendicular to the shaft (ES and RS)	2.5	870	1090	720	1570	705	350	535	950
	4	1420	1780	1160	2560	1330	680	1000	1800
	5	1955	2445	1605	3520	1815	930	1380	2465
	6	2490	3110	2050	4480	2300	1180	1760	3130

Tie-Rod Torque Specifications and Procedure

Appendix D

Model	Size (mm)	English units		Metric units	
		50% ft-lb	100% ft-lb	50% N-m	100% N-m
2.5x4-8 (65)	20x2.5	N/A	163	N/A	221
4x5-10 (100)	24x3	140	281	191	381
5x6-11 (125)	30x3.5	280	559	379	758
6x8-13 (150)	36x4	488	976	662	1324

Mark casings as shown below and apply torque values in this sequence or as noted in the instructions below.

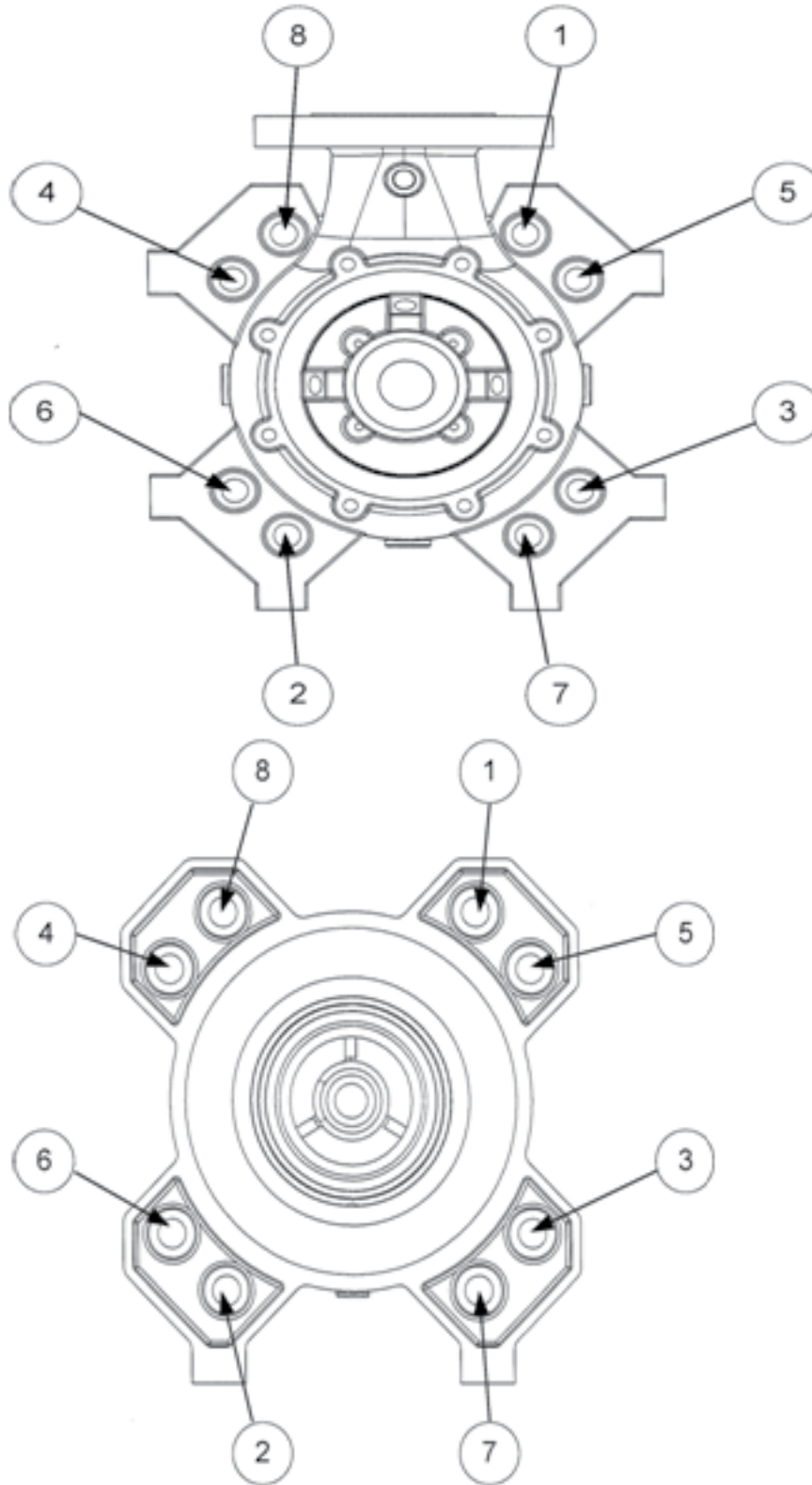

NOTICE: Check torquing tools to ensure the calibration dates are current; the use of an impact wrench is not allowed for torquing hardware.

1. Using a cross bolt pattern as noted in the figures above, carefully mate the components in the liquid end stack to ensure proper metal to metal contact of the assembly.
2. Use tie bolts nuts 1 thru 4 as shown.

3. Bring nuts up evenly by hand with a wrench
4. Snug nuts with wrench by hand to approx. 20 to 30 ft-lb.
5. Mount suction and discharge casing feet in final location.
6. Place liquid end assembly horizontally on a milled surface (the baseplate supplied with the pump can be used).
7. Check flatness of casing feet against the milled surface with a feeler gauge. If not flat, carefully and evenly loosen the four tie bolt nuts just enough to allow the casing feet to be moved so they are flat on the milled surface of the table. Variation is to be ≤ 0.003 in. If greater than 0.003 in, reface to meet requirements or replace casing feet.
8. Once the feet are flat on the table, retighten tie rod nuts 1 thru 4 in the manner defined above.
9. Tighten tie rod nuts 5 thru 8 in the same manner.
10. Tighten all eight tie rod nuts in sequence shown in Figure above by hand with torque wrench to approximately 50 ft-lb.
11. Mount dial indicators to shaft, measure and record the bearing housing face run-out on the suction and discharge casings (see sketch below). If any readings exceed 0.005 in, stop and address the issue. Note: Because there are no bearings mounted at this time, the shaft will need to be pushed inward from the discharge end until it stops. Set the gauges to zero and record the readings every 90°.

NOTICE:End suction pumps will only have a reading on the discharge side.

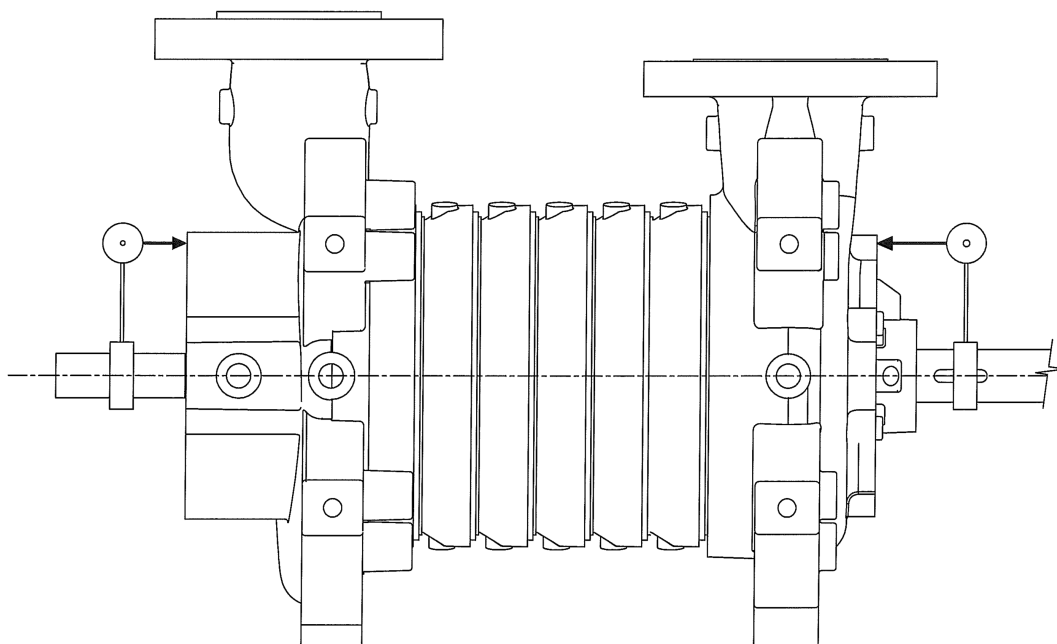

12. Using a torque wrench, torque the tie rod nuts in the following three increments using the sequence shown in Figure above: a. 100 ft-lb. b. 50% of full torque (if applicable). c. 100% of full torque.

Table 12:

Model	Size (mm)	English Units		Metric Units	
		50% ft-lb	100% ft-lb	50% N-m	100% N-m
2.5x4-8 (65)	20x2.5	N/A	163	N/A	221
4x5-10 (100)	24x3	140	281	191	381
5x6-11 (125)	30x3.5	280	559	379	758
6x8-13 (150)	36x4	488	976	662	1324

13. Re-check flatness of casing feet against the milled surface with a feeler gauge. Max variation is to be ≤ 0.003 in.

14. Re-mount dial indicators to shaft and measure and record the bearing housing face on the suction and discharge casings again. If any readings exceed 0.005 in, stop the build and address the issue.

Visit our website for the latest version of this document and more information:

<http://www.gouldspumps.com>



ENGINEERED FOR LIFE

Goulds Pumps
240 Fall Street
Seneca Falls, NY
USA
Tel. 1-800-446-8537
Fax (315) 568-2418