



Goulds 3640

API 610 11th Edition / ISO 13709 2nd Edition
API BB2 Two-Stage, Between-Bearing, Radially Split



ITT

ENGINEERED FOR LIFE

Goulds 3640

A Leader in API Engineered Pump Package Solutions...

Proven API Leadership

ITT Goulds Pumps is a proven leader in API Pumps

- Over 20,000 units installed
 - Over 17,000 OH2 / OH3s
 - Over 3,000 BB1 / BB2 / BB3 pumps
- 40+ years of API expertise
- Participating member on API 610 and API 682 committees

Family of API Pumps

ITT Goulds Pumps has a family of proven API pumps:

- Overhung pumps
- Single and two-stage between-bearing
- Multistage between-bearing pumps – axially split
- Barrel multistage - radially split
- Vertical, double casing pumps
- Specialty pumps

Global Coverage

ITT Goulds Pumps has the global coverage needed to serve multi-national companies in any region.

Industry Leading Hydraulic Coverage

- We offer extensive coverage to meet your process needs.
- Better hydraulic fits can mean improved efficiency and long-term reliability and parts life.

8000 HP / 6000 kW Testing Capability

- Our expanded test facility can test your pump in the most demanding conditions.
- Testing at rated speeds is critical to assess the impact of dynamic conditions including vibration.

API Engineering Expertise

- We are experts in packaging engineered pumps that meet your demanding applications – with true conformance to the latest API specifications.
- We have extensive experience in nearly every type of driver, bearing, seal, piping configuration, nozzle configuration, flange and baseplate design to meet your application needs.
- ITT is a world leader in technology and engineering including hydraulics, materials science, mechanical design and fluid dynamics.

Broad Applications

- Petroleum refining, production and distribution
- Petrochemical and demanding chemical processing
- High temperature applications including boiler circulation
- General industrial requiring high temperature or high pressures



Goulds 3640



Goulds Model 3640 between-bearings radially split process pumps are designed for smooth, reliable operation, and meet the toughest specification requirements of API 610 / ISO 13709 to assure extended service life.



High Temperature and Pressure Process Pumps that Meet or Exceed API 610 11th Edition / ISO 13709 2nd Edition

Safety, reliability and versatility are the key words for our 2 stage, centerline mounted, between-bearing (BB2) API 610 process pump.

Safety and Reliability

We provide engineered solutions with true conformance to the latest API specifications including the stringent emissions containment per API 682.

The result is a safe and rugged between-bearing API process pump designed for a 20-year life.

Versatility

- Capacity to 7,500 GPM (1700 m³/h)
- Total Dynamic Head to 2,500 feet (760 m)
- Temperature to 850° F (455° C)
- Pressure to 1,130 psig (75 bar)

Materials: Available in a wide range of materials including all API 610 constructions and custom application needs.

Engineered Hydraulics: Dense hydraulic coverage to better match your process for efficiency and reliability. Custom hydraulics are available.

Engineered Packaging with a wide range of drivers, seals, piping, nozzle configurations, flanges, base plates, and QC testing.

Services

- **Refinery:** Process feed, reflux, splitter bottoms, high-pressure process transfer

Goulds 3640 (API BB2)

API 610 11th Edition / ISO 13709 2nd Edition

API BB2 Two-Stage, Between-Bearing, Radially Split

HEAVY DUTY SHAFT

Minimum shaft deflection for extended seal bearing life. Sized to meet deflection and rotor dynamics requirements of API 610 / ISO 13709.

RENEWABLE WEAR RINGS

API 610 / ISO 13709 running clearances. Positively locked.

HEAVY DUTY RADIAL BEARING STANDARD

CENTERLINE MOUNTED CASING

Heavy duty mounting extensions accept API 610 / ISO 13709 nozzle loads and maintain pump alignment under extreme service conditions.

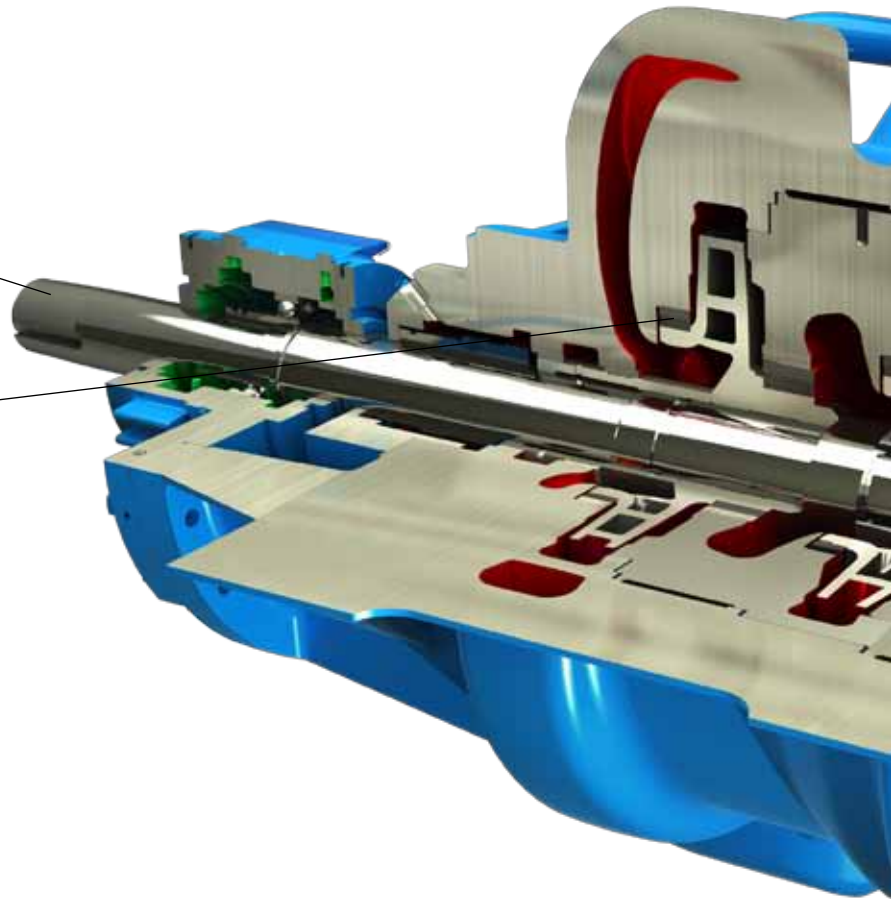

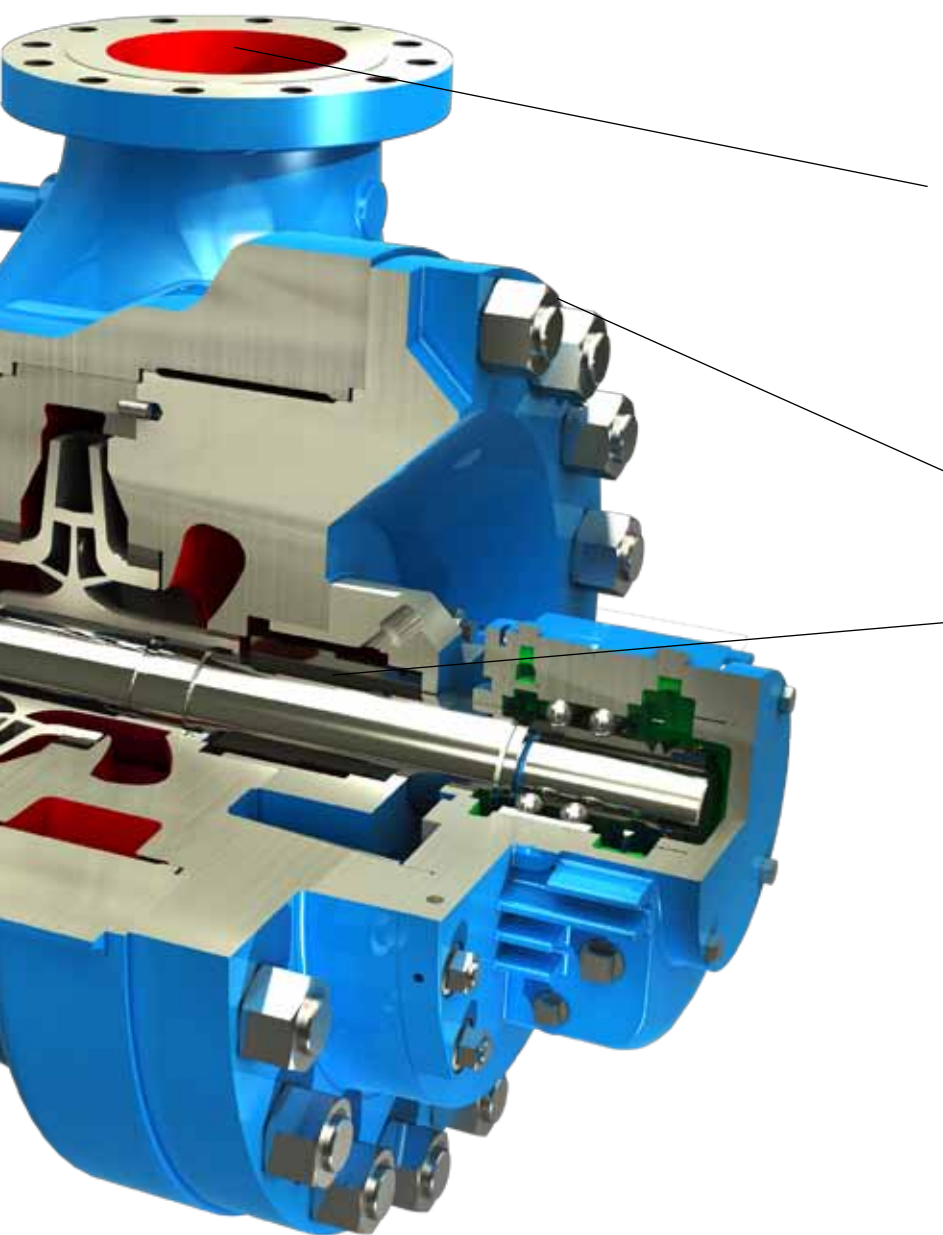

CLASS 300 RF FLANGES STANDARD

Other classes and facings optional.

RADIALLY SPLIT CASING

Designed specifically for high pressure / high temperature services. Fully confined controlled compression gaskets assure leak-proof sealing.

CASING HEAD ON OUTBOARD END

Allows removal of rotor without disturbing suction and discharge piping.

ENLARGED SEAL CHAMBERS

Conform to API 610 / ISO 13709 dimensional requirements. Allows use of wide range of API 682 / ISO 21049 cartridge mechanical seals to meet specific service conditions.

HEAVY DUTY THRUST BEARING

Duplex 40° angular contact standard. Ring oil lubricated. Other bearing configurations available to meet specific service requirements.

OPPOSED IMPELLERS ARRANGEMENT

Reduced axial forces for maximum bearing life. Impellers are driven by individual keys and positioned on shaft by dual locknuts. Staggered impeller vane tips for reduced pressure pulsations at vane passing frequency.

Hydraulic Coverage

Flow Capacity – 50 Hz

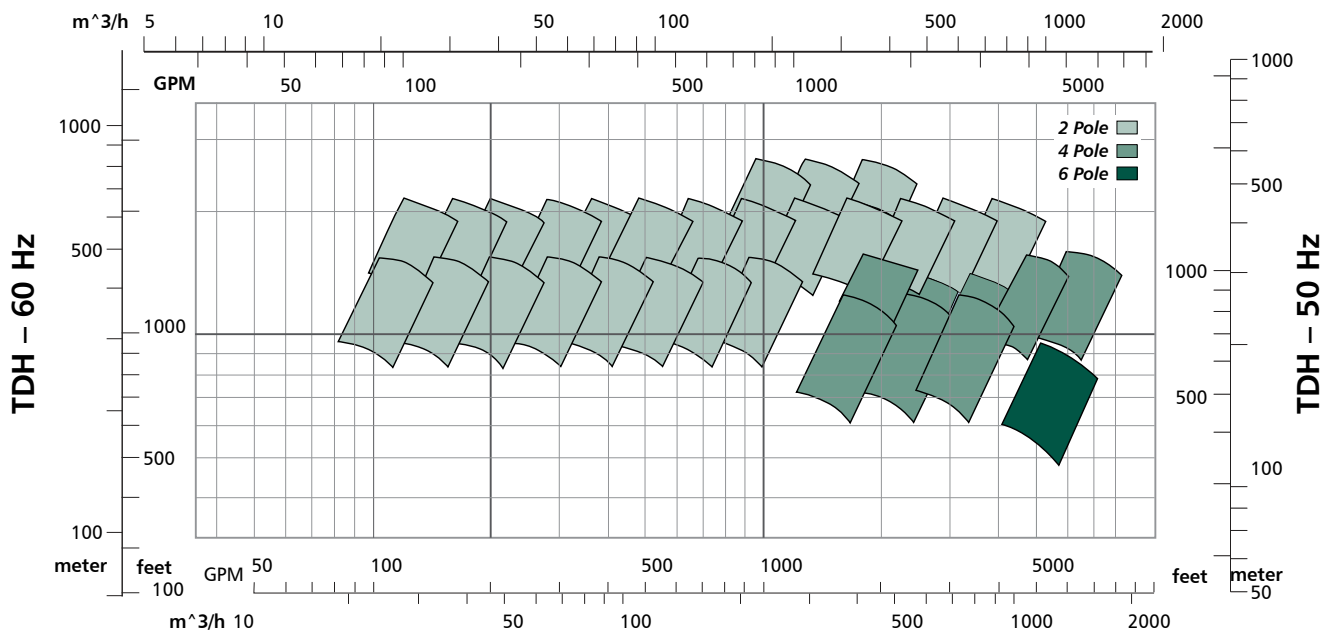

Flow Capacity – 60 Hz

Note: Hydraulics above represent 80% to 110% of best efficiency point (BEP).

PRO Services® Engineered Upgrade

Example of our PRO Services® Engineered upgrade capability. The following two-stage API BB2 Model 3640 was upgraded from an old edition of API 610 to the latest (10th) edition of API.



Original Pump



10th Edition Upgrade

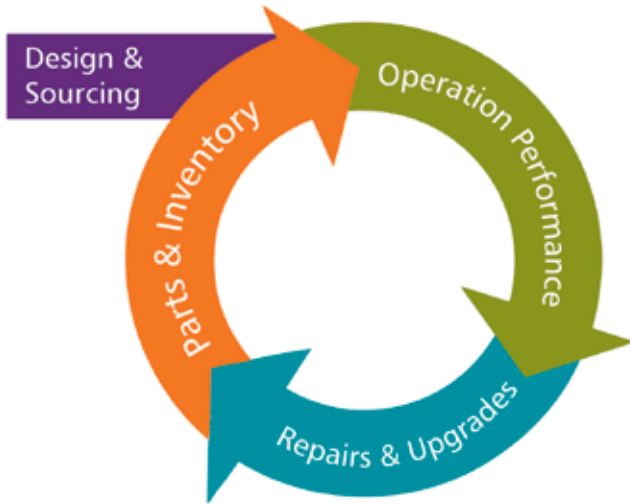

Reliability has no quitting time.

PRO Services provides an array of services focused on reducing equipment total cost of ownership (TCO) and increasing plant output, including predictive monitoring, maintenance contracts, field service, engineered upgrades, inventory management, and overhauls for pumps and other rotating equipment.



PRO Services provides OEM parts for Goulds Pumps, Bornemann Pumps, AC, Morris, Goynes, CB, HVC, UXN and ROV in a timely manner to meet end user requirements. Significant levels of inventory and quick response capability provides the necessary programs to meet all repair needs.

PRO Services provides programs of reliability services, energy assessments, asset management and training. These can be deployed as stand-alone or integrated solutions, tailored to the needs of your company.

PRO Services provides an array of repairs and upgrades services to extend equipment life. PRO Services helps customers develop effective maintenance and asset management programs to lower maintenance costs, improve uptime, reduce inventory costs and extend equipment life.

Visit our website at
www.gouldspumps.com

A Leader in API Engineered Pump Package Solutions

API Family of Pumps

Model 3700
OH-2



Model 3910
OH-3

Model 3620
3640
BB-2



Model 3610
BB-1



API Type	Goulds Model	Capacity GPM (M ³ /Hour)	TDH Feet (Meters)	Temperature °F (°C)	Pressure PSIG (kg/cm ²)
OH-2	3700	8500 (1930)	1200 (360)	800 (425)	870 (60)
OH-3	3910	6000 (1360)	750 (230)	650 (340)	600 (42)
BB-1	3610	50000 (11355)	700 (215)	300 (150)	300 (21)
BB-2	3640	7500 (1700)	2500 (760)	850 (455)	1130 (75)
BB-2	3620	20000 (4540)	1500 (455)	850 (455)	1000 (70)
BB-3	3600	8500 (1930)	9000 (2740)	400 (205)	4000 (275)
BB-5	7200CB	4000 (910)	9000 (2740)	800 (425)	4000 (275)
VS4	API 3171	3180 (720)	525 (160)	450 (232)	750 (50)
VS1	VIT	70000 (14760)	3500 (1060)	500 (260)	2500 (175)
VS6	VIC	70000 (14760)	3500 (1060)	500 (260)	2500 (175)



Model 3600
BB-3



Model 7200CB
BB-5



ENGINEERED FOR LIFE

240 Fall Street
 Seneca Falls, NY 13148
www.itt.com

© 2012 Goulds Pumps, Incorporated
 A subsidiary of ITT Corporation

Form B3640 04/13