

# **A-C Pump**

# **GOULDS PUMPS**

## Pumps for the Water/Wastewater Industries



**ITT Industries**

A-C Pump — Goulds Pumps



# A-C Pumps and Goulds Pumps – Performance proven for over 150 years...



## Where it counts—in the full range of municipal wastewater, drinking water and flood control services.

As North America grew and expanded, the need for wastewater treatment, flood control and drinking water service followed the growth of cities and the movement of population. A-C Pump, formerly the Allis-Chalmers Pump Division, and Goulds have been at the forefront of every major innovation in pumping technology, pioneering the designs and materials that have assured dependable, uninterrupted, high-efficiency service.

In 1848, Seabury S. Gould cast the first all-metal pump in the world in Seneca Falls, New York. He believed iron would overcome all the disadvantages of wood pumps. Gould wanted his pump to be strong and efficient, providing fresh flowing water for the pioneers who were opening the West, the farms in the East, and plantations down South. Goulds Pumps became the premier manufacturer of residential and industrial water pumps.

A-C Pump's track record goes back as far as 1872, when our first pumping engine—delivering 5,500 GPM at a 200 ft head—went into service for the City of Milwaukee, WI. Twelve years later, in 1884, we built the world's largest centrifugal pump in Chicago, rated at 48,000 GPM against a 13 ft head. We manufactured fifty of these high-reliability, high-performance units.

Our service to the pollution control industry also dates back to the 1880s when low-water conditions and pollution in the Milwaukee river threatened boating and the water supply. Large quantities of fresh Lake Michigan water was needed to flush the river. We originated a pump with a 14 foot diameter impeller—predecessor of today's axial flow and mixed-flow technology—that flushed the Milwaukee river by replacing its entire volume

every 18 hours. At the time, this was the largest quantity of water handled by any machine in the world...and it remains in service after more than 100 years!

By 1905, A-C pumps were installed at most of the municipal pumping applications throughout the USA. Our flood-control installation in Memphis, TN, helping to keep the Mississippi River within its levees, operated for more than fifty years. A-C axial flow pumps, installed for flood control applications in New Orleans, are among the largest installations of their kind, moving over a half million gallons of water each minute.

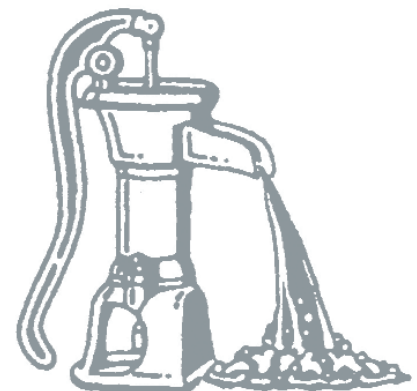

# Horizontal Split-Case, Double Suction Pumps for Water Service

## Horizontal Split-Case Pumps

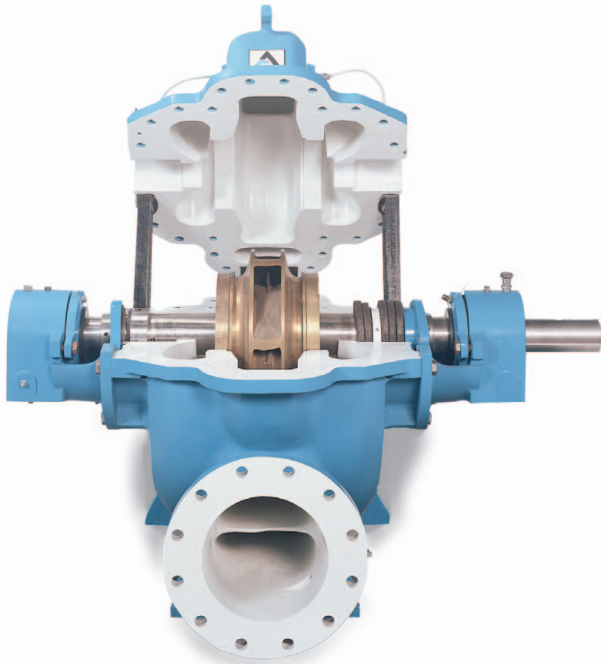

### High efficiencies, low energy costs, wide operating range.

The axially split-case pumps have been designed to keep energy and maintenance costs under control by delivering trouble-free long life and high efficiencies. Six different models are offered to provide the optimum solution for any application.

Sizes range to 78" (1981 mm) with capacities to 180,000 GPM (40,878 m<sup>3</sup>/h), heads to 850 feet (260 m), and temperatures to 350° F (177° C).

### Design features:

- Horizontal or vertical mounting saves space.
- Side Suction or Bottom Suction (some sizes) for application flexibility.
- Easy to install and service—flanges on common centerlines simplify piping layouts and horizontally split casing allows for ease of maintenance.
- Shaft sealing options to best meet requirements, packing with shaft sleeves or shaft-mounted component and cartridge mechanical seals.
- Available in various metallurgies, including all cast iron, bronze-fitted, stainless steel-fitted, and all stainless steel.
- Impeller wear rings available to increase impeller service life and provide easily renewable operating clearances.
- Double Suction Impellers and Dual Volute Casings (most sizes) to minimize bearing loads and shaft deflections.





# Horizontal and Vertical Non-Clog Wastewater Pumps

## NS Non-Clog Series— Horizontal



## NSW, NSY and NSX pumps.

The NS series can handle wastewater and liquids containing soft solids up to 9" (230 mm) without clogging. They can be utilized in preliminary, primary and secondary treatment. The NS series is available in sizes from 4" to 24" (100 mm to 600 mm) with capacities to 23,000 GPM (5,230 m<sup>3</sup>/hr) and heads to 300 ft (90 m).

### Design features:

- A two vane, non-clog impeller with a tapered shaft fit and contoured stainless impeller nut to prevent pumping material from hanging up and a tapered shaft fit for easy removal.
- A standardized design that helps reduce parts inventory by offering maximum interchangeability of parts.
- Clockwise and counterclockwise rotations with five different discharge positions provide the flexibility to best suit your piping arrangement needs.
- The back pull-out design allows for the removal of the complete rotating element without the need to disturb the piping.
- Large diameter shafts minimize deflection and increase packing or mechanical seal life.
- Support under the pump casing eliminates the risk of pipe shift during rotating assembly maintenance.
- A hardened, replaceable wear plate, located in the suction cover, protects against premature wear on the casing.

## WSY, SSE, and SSF Pumps

The dry pit pump line has been designed with large, unobstructed flow passages through the impeller and volute which make them ideally suited for pumping sewage, wastewater, and storm water. Numerous impellers are available with varying performance characteristics, solids handling capabilities, number of vanes, and impeller rotations so that the pumps can be custom sized to fit any given application. The heavy duty, rugged construction and conservative mechanical design minimizes pump vibration and maximizes pump life. The cast version of the dry pit pumps are available in sizes up to 54" (1,372 mm) with capacities to 110,000 GPM (25,000 m<sup>3</sup>/hr) with heads to 200 ft (61 m). Fabricated volute designs are available with virtually unlimited capacities.

### Design features:

- A back "pullout" feature allows the rotating element to be removed for inspection and maintenance without disturbing the suction or discharge connections.
- Materials available to suit any application.
- Large unobstructed flow passages.



## Non-Clog Series – Vertical Mount

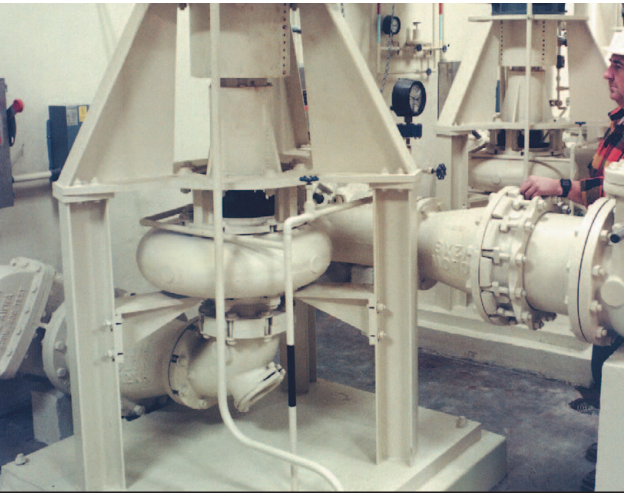

### NSWV, NSYV, NSXV, SSEV, SSFV and WSYV.

The vertical series is perfect for package lift stations and offers all of the benefits found in the horizontal series with the additional benefit of space savings. Cast volutes available in size ranges from 4" to 54" (100 mm to 1372 mm) with capacities to 110,000 GPM (25,000 m<sup>3</sup>/hr) and heads to 300 ft (90 m).

#### Design features:

- These space-saving vertical pumps require less floor space and less elaborate foundations due to the sturdy support pedestals.
- Some models are available in close-coupled configurations.
- Axial clearance between the impeller and suction cover is controlled by adding or removing shims between the outboard bearing cartridge and frame—making for simple and reliable impeller adjustment.
- Patented Tri-Base design eliminates vibration in vertical variable speed applications resulting in reduced noise and a more stable installation.
- Suction nozzle with hand hole clean-out.

## EQUISEAL® Dynamic Seal

### A Proven Performer in Reducing Sealing Problems.

A-C NSW, NSX and NSY pumps with Equiséal® dynamic seal are designed to eliminate costly replacement of packing and shaft sleeves and the need for any gland water.

A-C Pump has been supplying dynamic seals for almost 50 years. Our experience and seal design is proven, giving us confidence to apply dynamic seals where other pump manufacturers have failed.

#### With EQUISEAL® Dynamic Seal—

- **No metal-to-metal rubbing parts**— means virtually no wear, no maintenance and no need for gland water lubrication.
- **No critical operating clearances** are required for proper operation of the Equiséal® dynamic seal.
- **Packing** is eliminated thus greatly reducing stuffing box maintenance.
- **Mechanical shaft seals** with finely lapped faces and expensive replacement components are no longer required.
- **Field Conversion**— Pumps that are designed for the Equiséal® dynamic seal, which are currently in operation with packing or mechanical seals, can easily be converted over to the Equiséal® dynamic seal by obtaining an EQUISEAL® DYNAMIC SEAL CONVERSION KIT.

**STATIC SEAL** - When the pump is not in operation, a replaceable static seal system acts to prevent external leakage along the shaft.

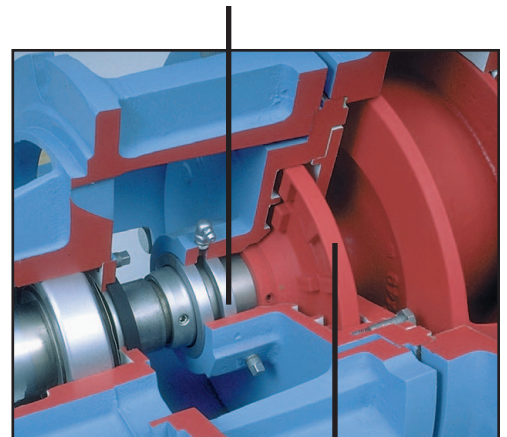

**EXPELLER** - the Equiséal® dynamic seal uses an auxiliary expeller in the seal chamber. As pumped liquid enters the dynamic seal stuffing box cavity, it is opposed by centrifugal force, generated by the auxiliary expeller creating a liquid sealing ring, thus preventing leakage.



# Self-Priming Pumps

## Trash Hog® Solids-Handling Pumps

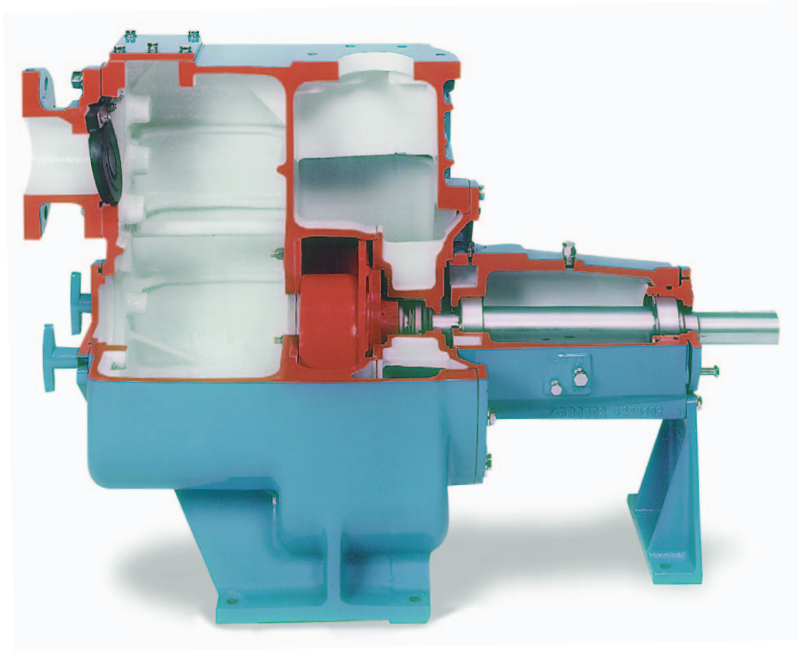

The Self-Priming pumps are available in sizes from 2" to 12" (76 mm to 300 mm) with capacities to 6,000 GPM (1,375 m<sup>3</sup>/hr) and heads to 200 ft (60 m). The solids handling, non-clog impeller is capable of passing solids up to 3" (76 mm). Designed to provide maximum uptime and ease of maintenance, these rugged pumps are constructed of cast-iron, 316 stainless steel or hard metal CD4MCu. Trash Hog is perfect for pumping raw sewage, sludge and wastewater.

For non-trash containing fluids, Prime Line offers higher efficiencies and faster priming. For corrosive fluids, the 3796 offers a wide range of metallurgy from Ductile Iron to Hastelloy C.

### Design features:

- Rugged casing with built in volute, check valve access port, clean-out port, suction and discharge drain traps.
- Dynamically balanced, 2 or 3 vane, semi-open, non-clog impeller capable of passing 3" (76 mm) spherical solids.
- To retain priming liquid, each pump is equipped with a pre-loaded and weighted elastomer suction check valve.
- Removal of the check valve access cover plate permits cleaning or removal of the check valve without disturbing suction or discharge piping.
- All models come with a heavy duty, replaceable wear plate.
- A lightweight clean-out cover, secured by easily removed T handles.
- Oil-lubricated, silicon carbide double seal system provides optimum wear resistance against entrained solids.

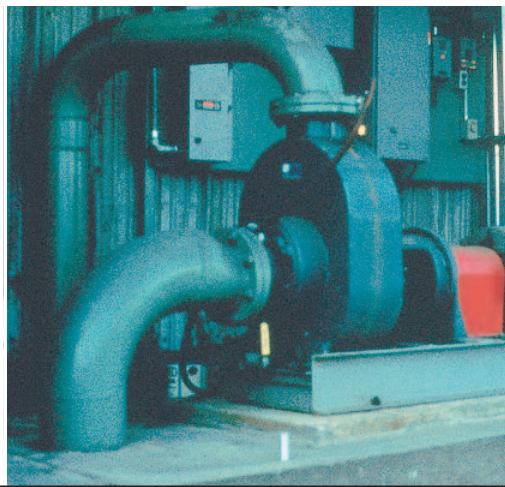
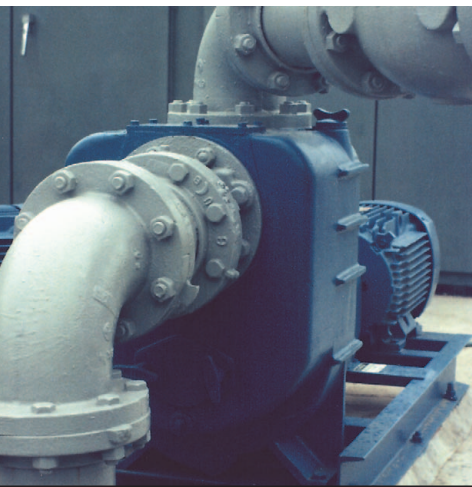

## Prime Line® Self-Priming Pumps for Clean Water

### Design features:

- Capacities to 7,000 GPM (1,600 m<sup>3</sup>/h)
- Heads to 250 feet (76 m)
- Temperature to 200° F (94° C)
- Suction Lifts to 25 feet (7.6 m)
- Solids Handling to 3" (76 mm)

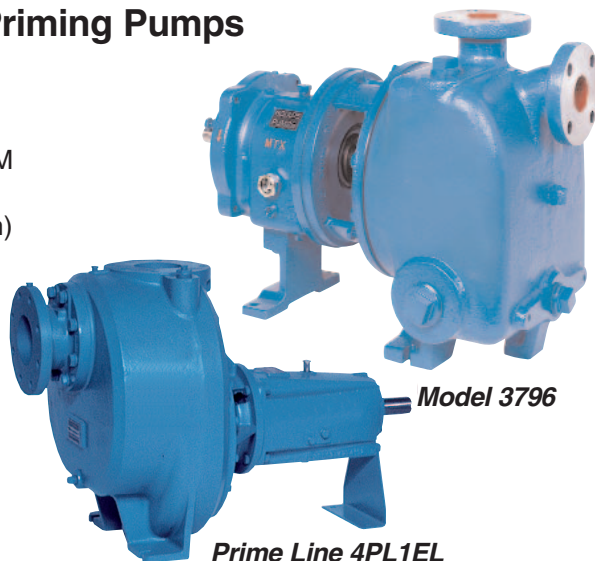

## 3796 Self-Priming ANSI Process Pumps

### Design features:

- Capacities to 1,250 GPM (284 m<sup>3</sup>/h)
- Heads to 430 feet (131 m)
- Temperature to 500° F (260° C)
- Suction Lifts to 25 feet (7.6 m)

# Hard Metal Pumps for Grit Services

## HS Horizontal HYDRO-SOLIDS Pump

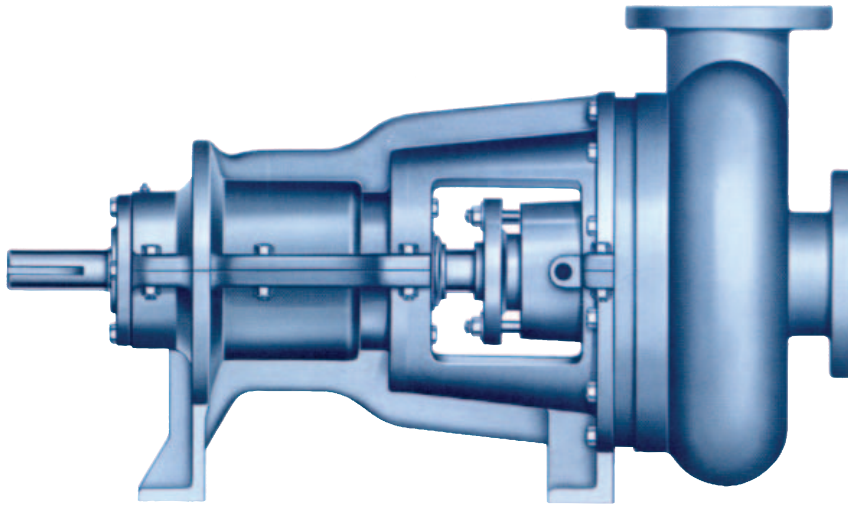

HS pumps handle spherical solids up to 10" (254 mm), stringy matter, slurries and fragile solids, all with clog-free dependability. A fully recessed impeller provides a straight flow path to the pump discharge reducing casing wear and improving solids handling capabilities. Sizes range from 2" to 10" (50 mm to 254 mm) with capacities to 7,000 GPM (1,600 m<sup>3</sup>/hr) and heads to 140 feet (43 m). Available in cast iron, high chrome iron (ASTM A532) with a hardness of 600 BHN for abrasion resistance or 316 stainless steel (ASTM A743, CF-8M) for corrosion resistance.

### Design features:

- Easy access, back pull-out design without piping disconnects, simplifies maintenance and minimizes downtime.
- Packing or mechanical seals are offered to suit fluid handling needs.
- Quiet low vibration operation reduces shaft and bearing fatigue.
- Available with open or cup type impellers. Cup impellers, in high chrome, minimize casing wear in heavy grit and sandy applications. They also improve handling of stringy solids.

### Model Slurry Pro® Design features:

- Capacities to 3,000 GPM (680 m<sup>3</sup>/h)
- Heads to 350 feet (107 m)
- Temperatures to 200° F (93° C)
- Pressures to 180 PSIG (1,240 kPa)
- Solids to 2" (50 mm)

### Model JC Design features:

- Capacities to 7,000 GPM (1,600 m<sup>3</sup>/h)
- Heads to 240 feet (73 m)
- Temperatures to 250° F (120° C)
- Pressures to 127 PSIG (875 kPa)
- Solids to 2.25" (57 mm)

### Model Whirl-Flo® Design features:

- Capacities to 2,200 GPM (500 m<sup>3</sup>/h)
- Heads to 220 feet (65 m)
- Pressures to 220 PSIG (1,517 kPa)
- Solids to 6" (152 mm)



Slurry Pro®

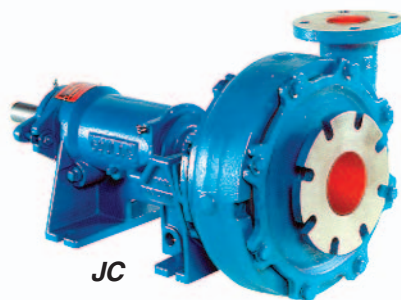

JC

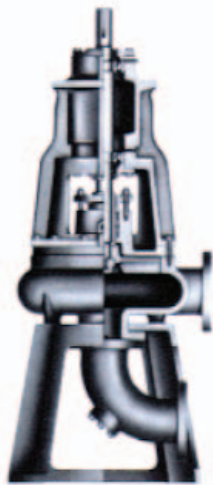

HSD Vertical Dry Pit Pump

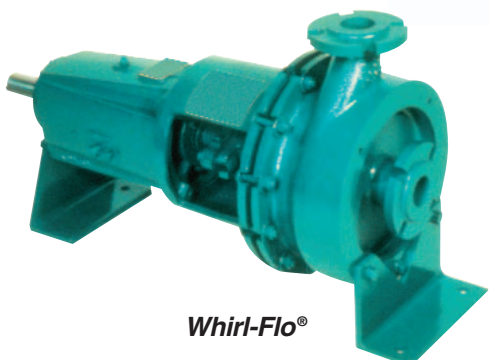

Whirl-Flo®



# Sump Pumps

## 3171 Vertical Sump and Process Pump



**Model 3171**

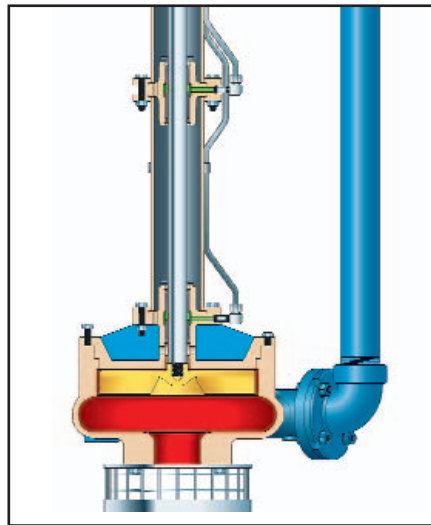

**Model CV 3171**

*Also Available  
Vortex Liquid End for  
Solids Handling*



**Model NM 3171**



**Model HSUL**



**Model HSU**

Goolds Pumps offers a wide range of sump pumps in submersible and wet pit designs. The 3171 line offers metallic constructions from cast iron to CD4MCu and non-metallic FRP. Also offered is a recessed impeller design specifically for solids handling.

The HSU and HSUL are submersible recessed impeller pumps. Submersible motors are UL listed explosion-proof for use in Class I, Groups C and D hazardous locations.

### Model 3171 Design features:

- Self-Priming, rugged double row thrust bearing with heavy duty one-piece shaft and external Impeller adjustment
- Available in a wide range of alloys
- Open Impeller design (also available with recessed design)
- Vapor Proof Option: Choice of packing, or mechanical seal for containing sump vapors
- Capacities to 3,180 GPM (722 m<sup>3</sup>/h)
- Heads to 310 feet (95 m)
- Temperatures to 450° F (232° C)
- Pit depths to 20 feet (6 m)

### Model CV 3171 Design features:

- Capacities to 1,300 GPM (295 m<sup>3</sup>/h)
- Heads to 230 feet (126 m)
- Temperatures to 450° F (232° C)
- Pit depths to 20 feet (6 m)

### Model NM 3171 Design features:

- For severe corrosive applications
- Casing and Impeller interchangeable with Model NM 3196
- Cost effective alternative to high alloys
- Capacities to 1,250 GPM (284 m<sup>3</sup>/h)
- Heads to 300 feet (92 m)
- Temperatures to 200° F (79° C)
- Pit depths to 16 feet (5 m)

### Model HSUL and HSU Design features:

- For service conditions whether large, stringy, fibrous solids, or abrasive slurries
- Capacities to 2,800 GPM (636 m<sup>3</sup>/h)
- Heads to 140 feet (43 m)
- Temperatures to 194° F (90° C)
- Solids to 6" (152 mm)
- HSUL available with slide rails



# Chemical Injection Pumps

## Model 3196 ANSI Process Pumps

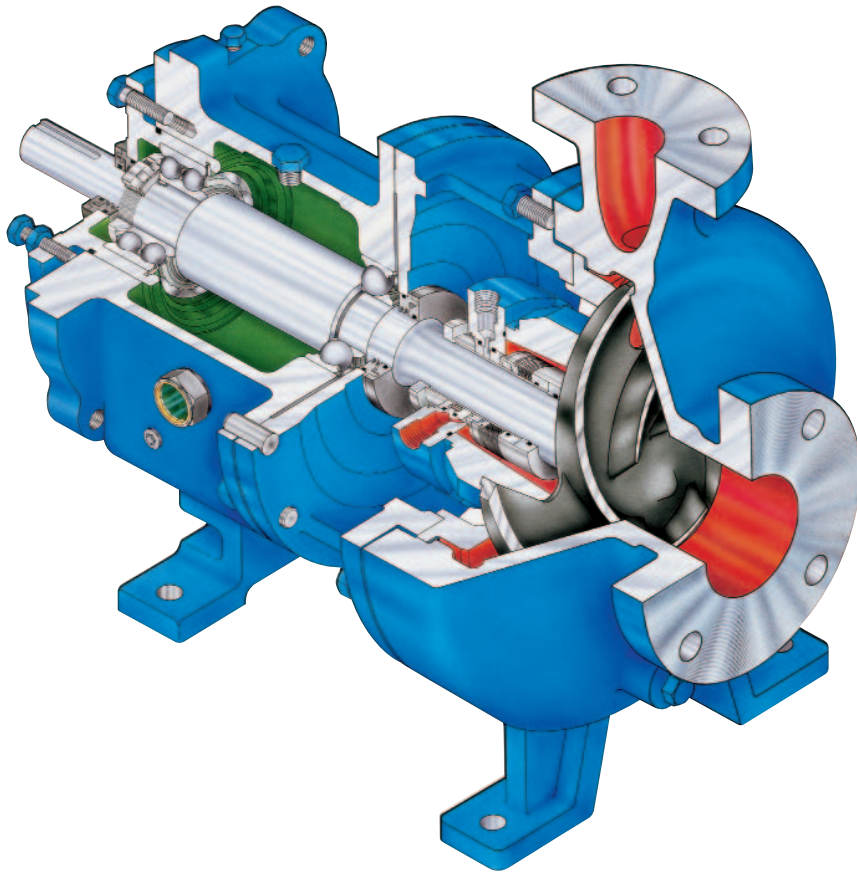

Goulds offers the most complete range of pumps for chemical and general services in any water or waste water treatment facility.

### Model 3196 ANSI Process Pump Design features:

- Flows to 6500 gpm (1450 m<sup>3</sup>/h)
- Heads to 700 ft (213 m)
- Temperatures to 700° F (371° C)
- Materials: DI, 316SS, Alloy 20, CD4MCu, Hastalloy B and C, Nickel, Titanium, Zirconium.
- Solids handling Max: 1 1/8"
- Services: Water Treatment and Distribution, Booster Pumps, Disposal, Chemical Injection, Water circulation and General Services

### Model NM 3196 Non-Metallic Pump Design features:

- Flows to 800 gpm (182 m<sup>3</sup>/h)
- Heads to 500 ft (152 m)
- Temperatures to 200° F (93° C)
- Materials: GPM-2000 (Vinylester)
- Solids handling Max: 1 1/8"
- Services: Highly Corrosive Acids and Chlorides, Chemical Injection and Transfer Pumps

### Model 3298 Lined Mag-Drive Pump Design features:

- Flows to 1200 gpm (270 m<sup>3</sup>/h)
- Heads to 470 ft (143 m)
- Temperatures to 250° F (121° C)
- Materials: TEFZEL® (ETFE)
- Solids handling Max: 1 1/32"
- Services: Chemical Injection, Transfer Pumps, Highly Corrosive Chemicals, and Batch Processes

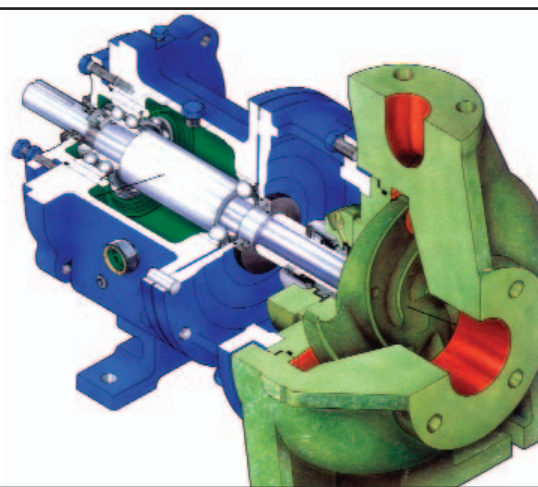

Model NM 3196

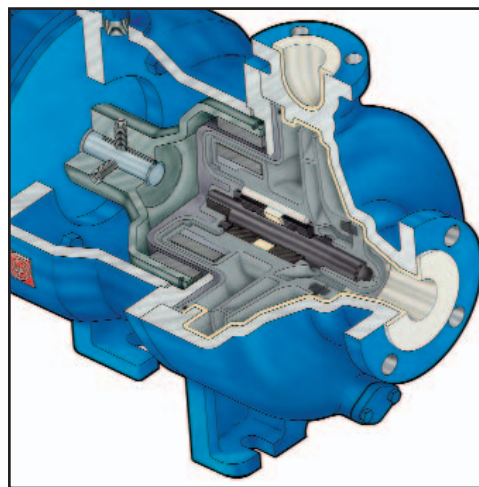

Model 3298

# Vertical Pumps for Water Service

## VIT Vertical Turbine



## Model VIT Pump

The vertical turbine pump is designed for high pressure or high capacity and when ease of maintenance is a prime consideration. Available in a wide variety of materials for the most erosive and corrosive environments. Services include river water intake, irrigation, booster, and water transfer.

### Design Features:

- Capacities to 60,000 GPM (13,627 m<sup>3</sup>/h)
- Heads to 3,500 feet (1067 m)
- Temperatures to 450°F (232°C)

## Vertical Column Pumps: WCAX, YDD, WCA, WCB, WMCC and WMCE Pumps

The vertical column pump line has been designed to maximize pumping efficiency over a wide range of capacities and heads. ITT A-C Pump offers some of the most efficient and reliable vertical wet pit column pumps available anywhere in the world. The column pumps are available in sizes up to 120" (3050mm) diameter with capacities up to 500,000 GPM (114,000m<sup>3</sup>/hr) and heads to 600 ft (185m)

### Design features:

- A top "pullout" design is available on all models allowing the rotating element and wearing parts to be removed from the top of the pump while leaving the discharge connections and pump shell in place.
- Materials available to suit any application.
- Available in varying sizes, lengths, and configurations to suit any application.





# Axial Flow Pumps

## AF Axial Flow



### Model AF Axial Flow Design features:

For continuous circulation of corrosive/abrasive solutions, slurried and process wastes. Fabricated or cast elbow designs available. Unmatched for low head, high capacity pumping.

- Capacities to 200,000 gpm (35,000 m<sup>3</sup>/h)
- Heads to 30 ft (9 m)
- Temperatures to 350° F (180° C)
- Pressures to 150 PSIG (1034 kPa)
- Solids to 9" (228 mm)

## Horizontal Axial flow Pumps WCXH Pumps

The horizontal axial flow pump is designed for pumping large capacities with low lift requirements. It is designed for reliable, efficient pumping operation and for ease of maintenance. The WCXH pump is available in sizes up to 132" (3355mm) with capacities up to 600,000 GPM (136,500m<sup>3</sup>/hr) and heads to 25 ft (7.5m).

### Design features:

- The rotating element sits "high and dry" during idle projects. This helps to maximize pump life since the pump is not subject to the corrosive effects of the pumped fluid during these idle projects.
- The casing is split axially to allow the rotating element to be removed without disturbing the suction or discharge lines.
- The impeller has large unobstructed flow passages which allows pumping of large solids and debris often associated with flood or storm waters.



# PUMPSMART® Process System



PumpSmart® control systems significantly reduce pump life cycle costs: PumpSmart is an advanced technology system that works with any centrifugal pump utilizing a smart VFD controller and proprietary control software.

## PumpSmart will provide:

### ■ Significantly Lower Energy Costs.

Utilizing a smart VFD to tailor pump output to the exact system requirements, dramatically lowers energy consumption. A typical 75 HP pump installation will save over \$15,000 annually.

■ **Enhanced Reliability through Failure Prevention.** Exclusive fault tolerance protects your pump from the most common causes of failure; closed valves, dry running, cavitation, and low flow, by preventing the pump from operating under these conditions. As a result, significant increases in reliability (MTBF) are achieved, reducing maintenance costs and maximizing plant uptime.

■ **Advanced Process Control.** PumpSmart's proprietary software provides precise output control without the need for commonly required system tuning. In addition, all system conditions and upsets are recorded for analysis and can be enabled for real time asset management.

PumpSmart may also eliminate the need for control valves, flow meters, recirculation piping, and suction valves, reducing capital and installation costs.

**1**

**Control valves may be eliminated -** PumpSmart systems match pump performance to exact system conditions.

**2**

**Starters may be eliminated -** PumpSmart systems have an integral starter.

**3**

**Flowmeters may be eliminated -** PumpSmart systems utilize **patented** internal flow measurement.

**4**

**Recirculation lines and valves may be eliminated -** PumpSmart systems provide low flow protection.

## PumpSmart Process Systems

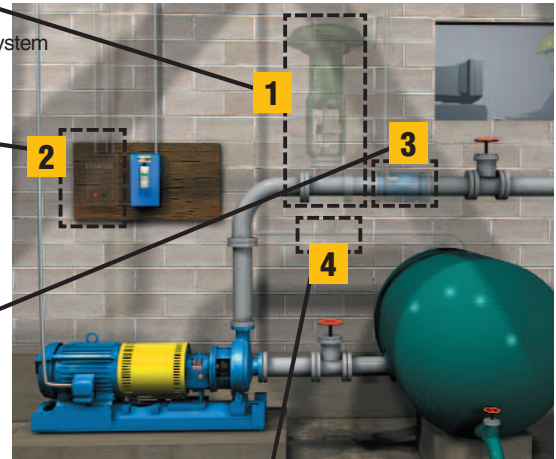

## PRO Services: Integrated Service Solutions



## In The Shop...Or On The Road... Around The World.

PRO Services engineers and technicians are experienced with servicing all types of pumps and rotating equipment. Customers utilize PRO Services for commissioning, troubleshooting, and field repairs of pumps, pumping systems and other pieces of rotating equipment.

PRO Services engineers and technicians utilize state-of-the-art techniques and equipment to provide the highest level of service in the industry.

- \* Routine Maintenance
- \* Field Repair
- \* Plant Shutdown
- \* Contract Services
- \* Turnkey Service

- \* Technical Expertise
- \* Fast Turnaround
- \* Emergency Service – 24 hours/day, 7 days/week, 365 days/year
- \* Factory Trained Service Personnel
- \* ISO Quality
- \* Safety Certified



ITT Industries

A-C Pump — Goulds Pumps

Visit our website at [www.gouldspumps.com](http://www.gouldspumps.com)