



## M-Series Vertical Turbine Pumps



A-C Pump



**ITT Industries**  
*Engineered for life*

# A-C Vertical Turbine Pumps

## Flexibility by Design: Four Pump Models, One Common Bowl Assembly

The four different pump models in the vertical turbine line have one thing in common - the hydraulic design of the pump bowl assembly. Using state-of-the-art techniques in turbine pump design, The ITT A-C vertical turbine line covers a wide range of hydraulic conditions to meet virtually every pumping service in the industry with optimum efficiency.

A-C Pumps' flexibility of design allows the use of a wide range of materials and design features to meet the custom requirements of the user. No matter what the requirements, whether low first cost, ease of maintenance, optimum efficiency or tough service conditions, ITT A-C can make the pump to best satisfy the requirements.

This bulletin is designed to assist the user in selecting the best pump for the conditions required, however, any questions will be answered promptly by calling the A-C Pump sales representative in your area.

**Model MVT-FF**

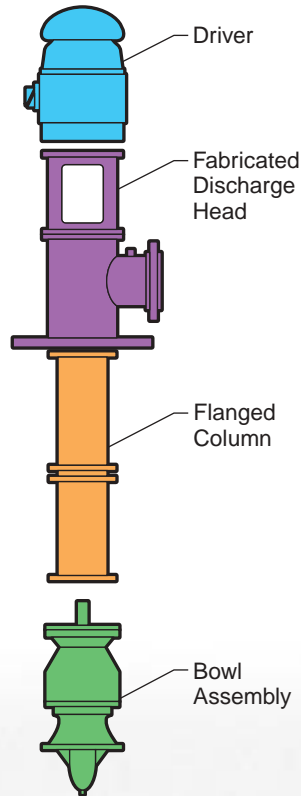

**Model MVC**

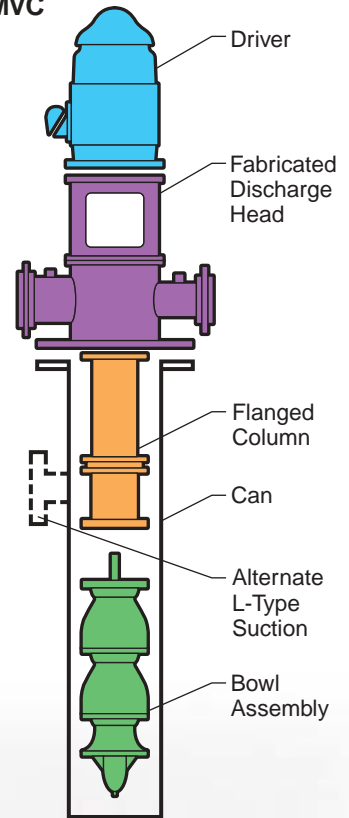

**Model MVS**

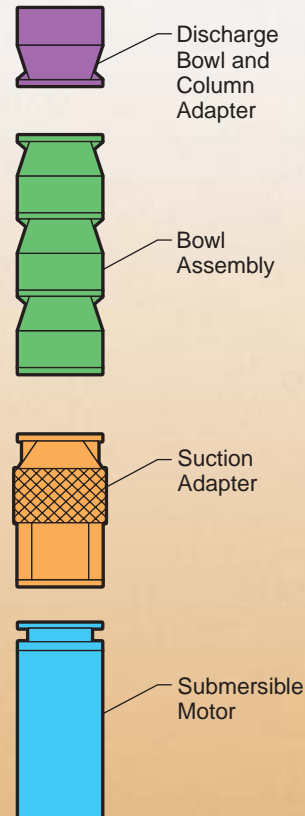

# Designed for a Wide Variety of Services

---



## A-C Vertical Turbines for General Transfer Pumping

Municipalities worldwide have relied on A-C for moving their water from one place to another. Without a doubt, the vertical turbine product continues to be a preferred solution for such general transfer services. And whether the facility delivers 2 MGD or 20 MGD, the broad hydraulic range offered by A-C will yield pump selections that maximize efficiencies and minimize operating costs.



## A-C Models MVT and MVC for Reverse Osmosis Applications

At the heart of any dependable water filtration facility are dependable pumps. The robust design of A-C vertical turbine products makes them ideally suited for the demanding high-pressure pumping requirements of reverse osmosis applications. Industrial duty, standard design features ensure extended mean time between failure for the lowest total installed cost of any comparable product.



## Wide Range of Materials Available

A-C Pump offers vertical turbine pumps in a wide variety of materials to ensure compatibility with virtually any pumpage. From cast iron/bronze-fitted, to all bronze, to all alloy constructions, A-C can supply materials to sustain the corrosive and erosive effects of such fluids as raw water, chlorinated water, and seawater. This includes optional hard-facings for wear components such as shafts and bearings.

# Hydraulic Coverage for models MVT, MVC and MVS

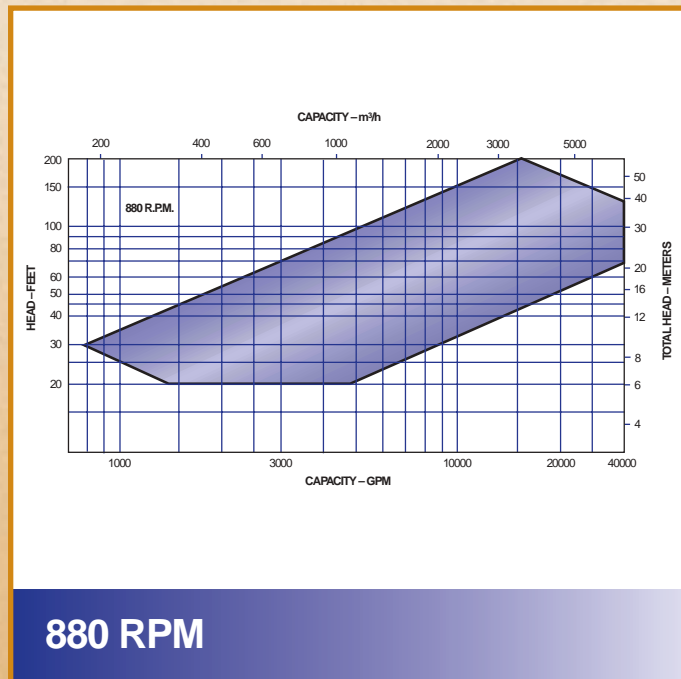
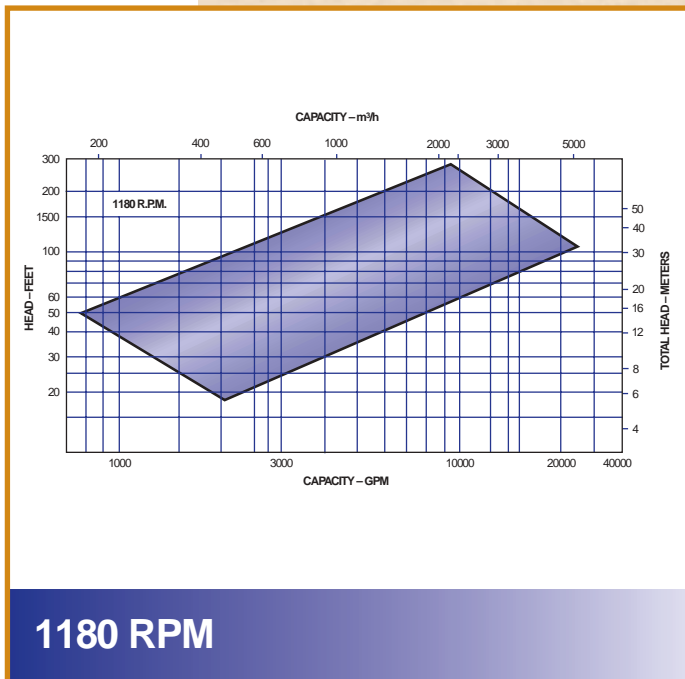
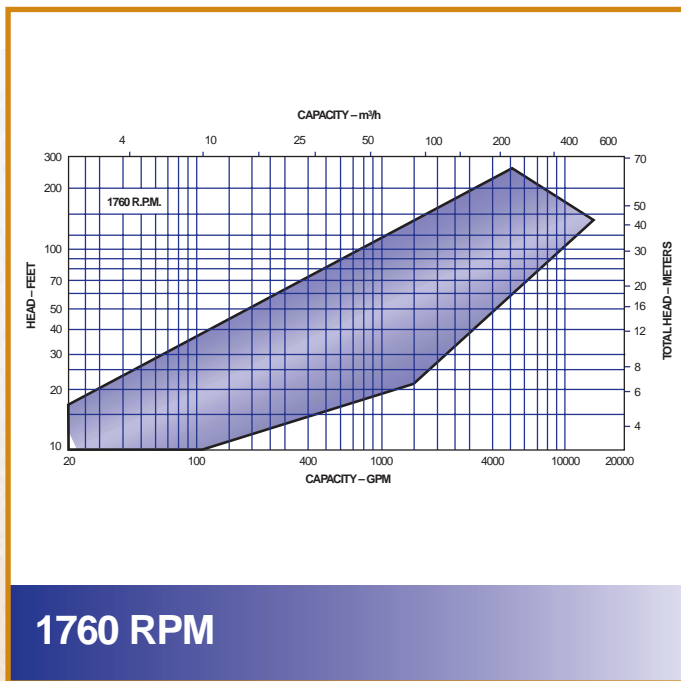
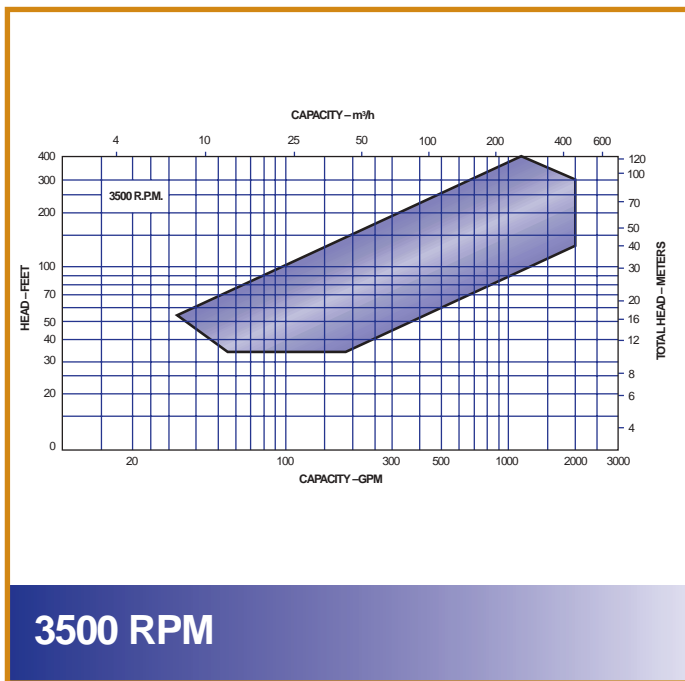

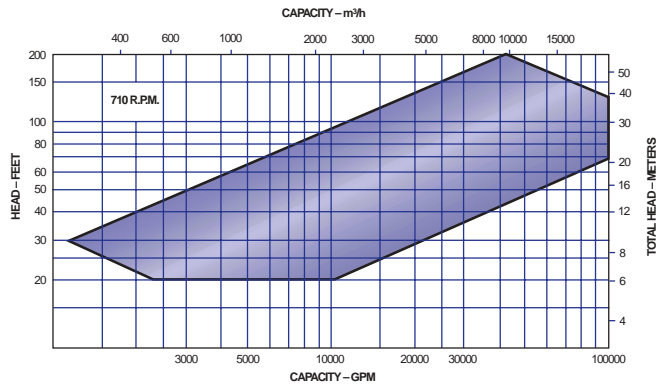

**710 RPM**

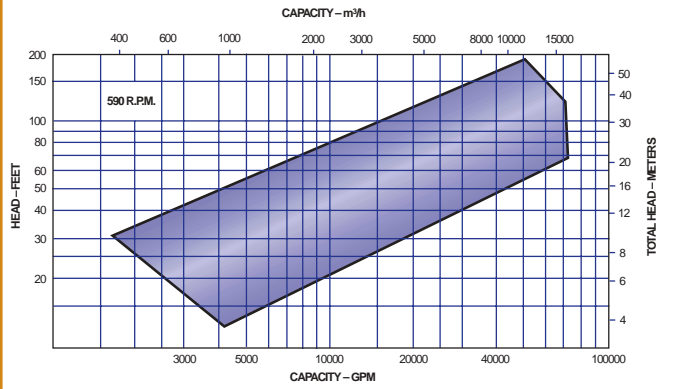

**590 RPM**

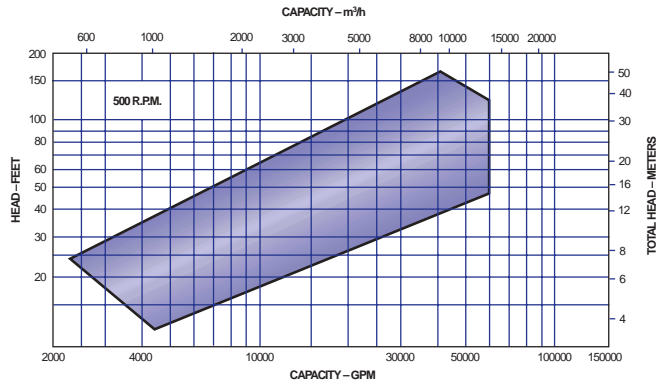

**500 RPM**

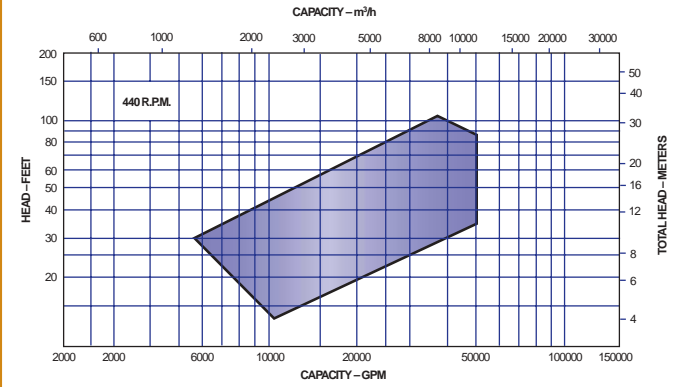

**440 RPM**

# Pump Bowl Assembly

The bowl assembly is the heart of the vertical turbine pump. The impeller and diffuser type casing are designed to deliver the head and capacity that your system requires in the most efficient way possible. The fact that the vertical turbine pump can be multi-staged allows maximum flexibility both in the initial pump selection and in the event that future system modifications require a change in the pump rating. Submerged impellers allow the pump to be started without priming.

A variety of material options allows the selection of a pump best suited for even the most severe services. The many bowl assembly options available assure that the vertical turbine pump satisfies the users' needs for safe, efficient, reliable and maintenance-free operation.

## Standard Design Features

1. **SUCTION BELL** - Allows smooth entry of liquid into impeller eye, minimizes vortex formation.
2. **SUCTION BELL BEARING** - Provided for shaft stability.
3. **SAND COLLAR** - Prevents solids from entering suction bearing.
4. **IMPELLER** - Semi-open or enclosed for appropriate service.
5. **TAPER LOCK** - Alloy steel for fastening impellers on 17" and smaller sizes.
6. **KEYED** - Impeller fastened onto the shaft by keyed split ring.
7. **PUMP SHAFT** - Heavy duty 416SS standard, available in 316SS, 17-4 PH, Monel and other alloys for strength and corrosion resistance.
8. **DIFFUSER BOWL** - Available in variety of cast materials. Glass lined cast iron standard through 18" sizes.
9. **STAGES** - Flanged and bolted together for ease of maintenance.
10. **SLEEVE TYPE BEARING** - Provided at each stage to assure stable operation away from critical speed.
11. **FLANGED BOWLS** - Registered fits assure positive alignment, ease of maintenance.

*In addition to standard features and options shown here, other features are available.*

- A. Hydraulic balancing of impellers to reduce axial downthrust and achieve longer thrust bearing life.
- B. Independent flushing of bowl bearings and wear rings for abrasive services.
- C. Hard facing of shaft journals and bearings to protect against abrasion and increase interval between maintenance periods.
- D. Interior coating on bowls for improved efficiency.
- E. Dynamic balancing of impellers.
- F. Strainers to prevent foreign objects from entering the pump.

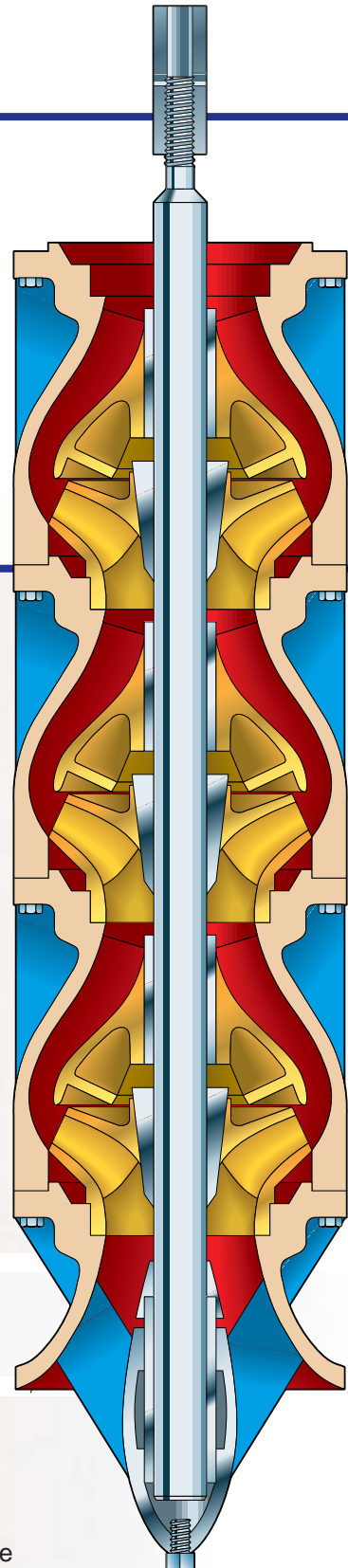

# Pump Bowl Assembly Options

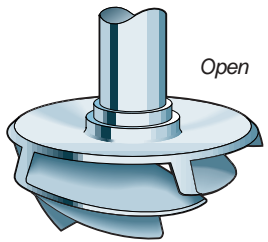

Open

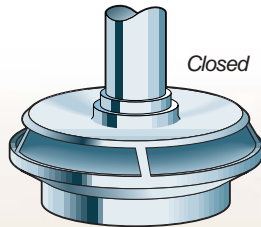

Closed

## CHOICE OF SEMI-OPEN OR ENCLOSED IMPELLERS

Available in alloy construction for a wide range of corrosive/abrasive services.

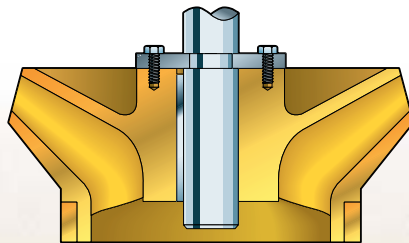

## KEYED IMPELLERS

Keyed Impellers are standard on 18" and larger sizes; furnished on all pumps for temperatures above 180° F (82° C) and on cryogenic services. Regardless of size, keyed impellers provide ease of maintenance and positive locking under fluctuating load and temperature conditions.

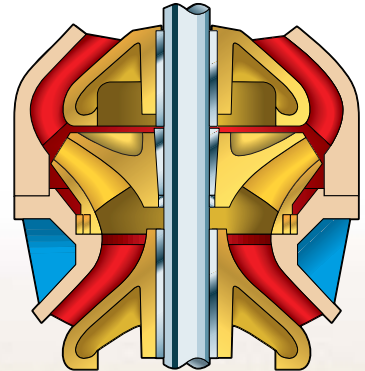

## DUAL WEAR RINGS

Available for enclosed impellers and bowls; permits re-establishing initial running clearances and efficiency at lower cost. Hard facing of wear rings can be flushed when solids are present in pumpage.



## STRAINERS

Basket or cone strainers are available to provide protection from large solids.

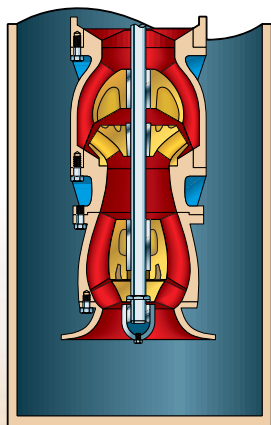

## LOW NPSH FIRST STAGE X IMPELLERS

For low NPSH<sub>A</sub> applications. Both large eye and mixed flow first stages available; minimizes pump length.

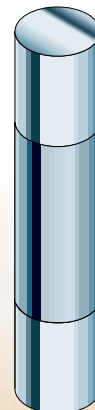

## HARDFACING

Hardfacing the surface of bearing and shaft to protect against wear from abrasives in the bearing area.

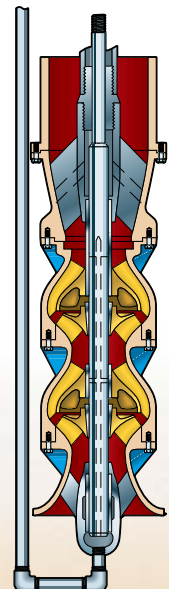

## RIFLE DRILLING DISCHARGE BOWL

Rifle drilling of bowl shafts available for bearing protection on abrasive services.

Discharge bowl included with enclosed lineshaft construction.

# Flanged Column

Column sections are provided with flanged ends incorporating registered fits for ease of alignment during assembly. Facilitates disassembly where corrosion is a problem. Our standard bearing retainers are welded into the column section.

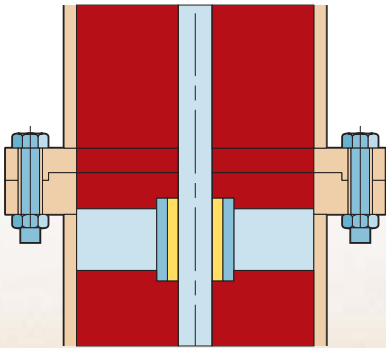

## OPEN LINESHAFT BEARING

Flanged column / product lubricated lineshaft is recommended for ease of maintenance or whenever a special bearing material is required.

Keyed lineshaft coupling available in all sizes for ease of maintenance. Various bearing materials available. Renewable shaft sleeve or hard facing of shaft available for longer life.

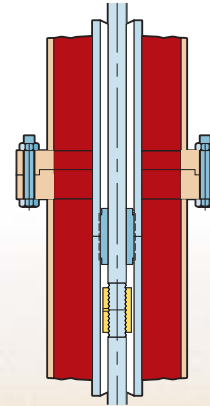

## ENCLOSED LINESHAFT

The lineshaft is protected by water flushing the enclosing tube bearing on corrosive / abrasive services. Oil lubricated lineshaft available on long settings.

Alignment is attained by register fit between the flange faces.

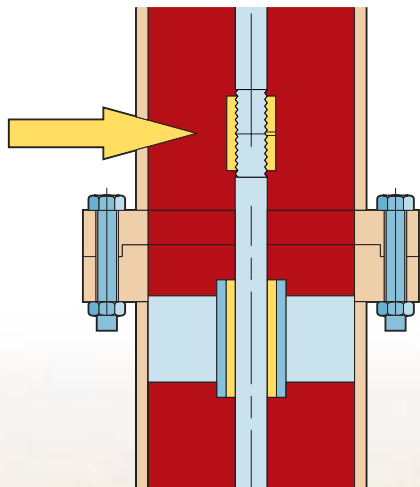

## THREADED LINESHAFT COUPLING

Threaded lineshaft coupling is commonly used for lower horsepower pumps. It is less expensive.

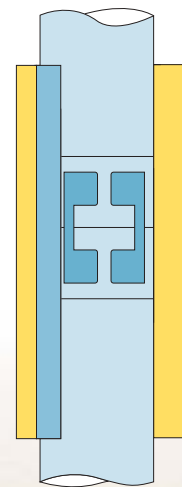

## KEYED LINESHAFT

Keyed lineshaft coupling is recommended for motors larger than 500 HP. It provides ease of maintenance.



# Coupling Arrangements

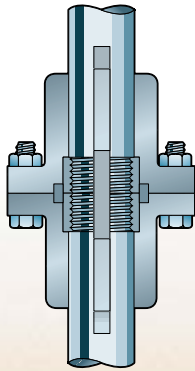

## RIGID FLANGED COUPLING (Type AR)

To couple pump to vertical hollow shaft driver. Impeller adjustment is performed on adjusting nut located on top of motor.

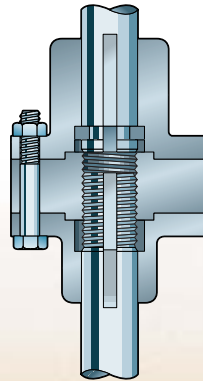

## ADJUSTABLE COUPLING (Type A)

For vertical solid shaft driver. Impeller adjustment made by using adjustable plate in the coupling.

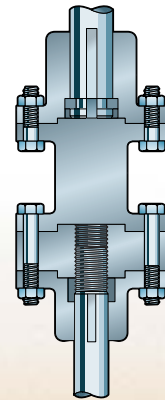

## ADJUSTABLE SPACER COUPLING (Type AS)

Same function as type A coupling with addition of spacer. Spacer may be removed for mechanical seal maintenance without disturbing driver.

# Discharge Heads

The discharge head functions to change the direction of flow from vertical to horizontal and to couple the pump to the system piping in addition to supporting and aligning the driver. Discharge head accommodates all modes of drivers including hollow shaft and solid shaft motors, right angle gears, vertical steam turbines, etc. Optional sub-base can be supplied. A-C Pump offers three basic types for maximum flexibility.

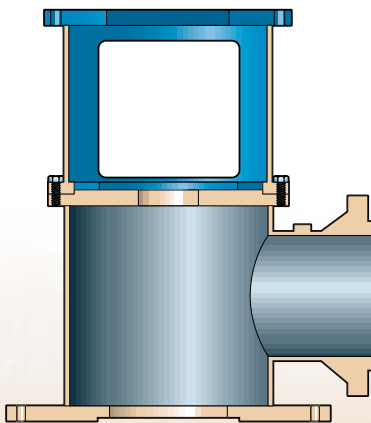

## FABRICATED DISCHARGE HEAD

For pressures exceeding cast head limitations or services that require alloy construction such as high or low temperature or corrosive services. Segmented elbow available for efficiency improvement. Large hand holes for easy access. Base flange can be machined to match ANSI tank flange. Bearing at base of discharge head for better shaft support.

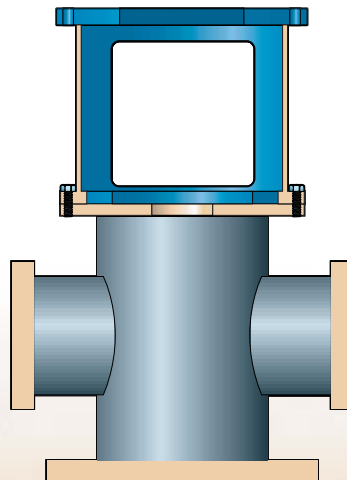

## MVC-T

MVC-T can also be supplied as a MVC-L with the pump suction in the can.

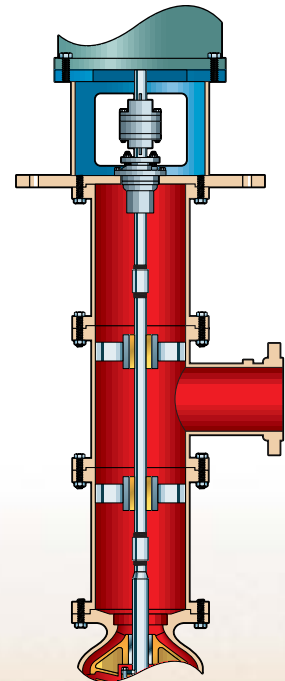

## BELOW GROUND DISCHARGE HEAD

Use whenever MVT pump is required to adapt to an underground discharge system.

# Sealing Flexibility

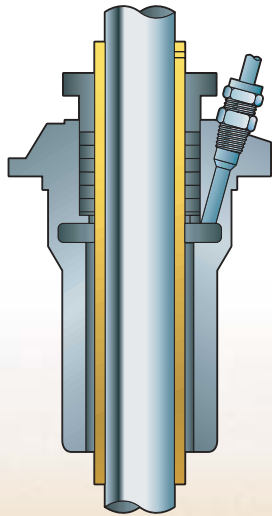

## PACKED BOX WITH SLEEVE OPEN LINESHAFT

Whenever packing lubrication leakage can be tolerated and the discharge pressure does not exceed 150 psi, a packed box may be used. Optional headshaft sleeve available to protect shaft.

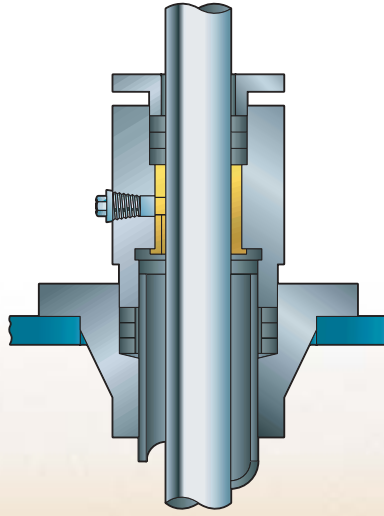

## WATER FLUSH ENCLOSED LINESHAFT

Water flush tube connection is supplied when pressurized water is introduced into the enclosing tube for bearing protection on abrasive services.

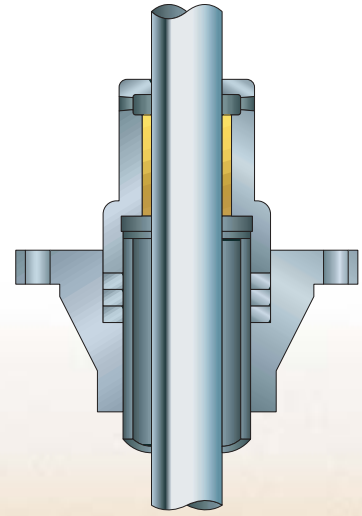

## OIL LUBRICATED ENCLOSED LINESHAFT

Oil lubricated option is recommended when water elevation would cause the upper lineshaft bearings to run without lubrication during start-up. Oil is fed through tapped opening and allowed to gravitate down enclosing tube lubricating bearings.

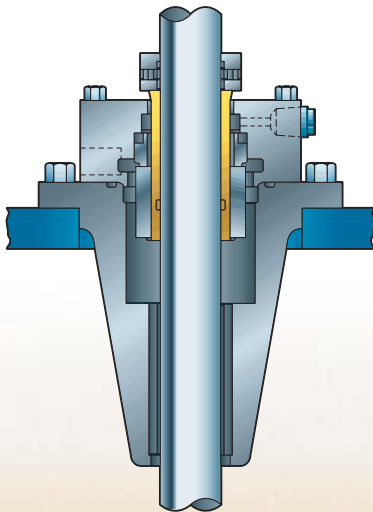

## SINGLE SEAL

Most popular method — used for low to medium pressures. Cartridge style for ease of installation and maintenance.

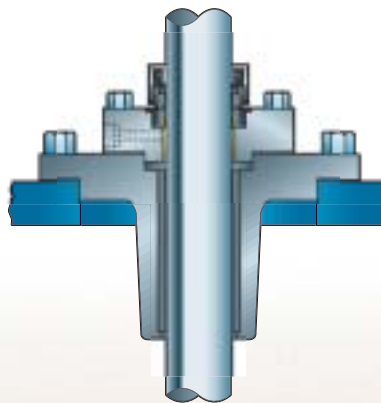

## OUTSIDE MOUNTED SEALS

Provides a method of no-leak sealing for low pressure and water application.

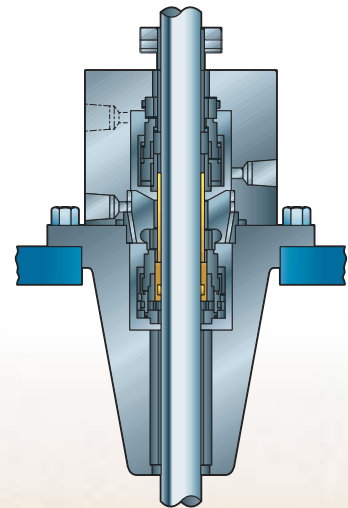

## TANDEM SEALS

Two seals mounted in-line. Chamber between seals can be filled with a buffer liquid and may be fitted with a pressure sensitive annunciating device for safety.



# Model MVT-FF

## Municipal Vertical Turbine Pump

- Capacities to 65,000 GPM (14,763 m<sup>3</sup>/h)
- Heads to 3,500 feet (1,067m)
- Temperatures to 500° F (260° C)
- Bowl sizes from 6" to 55"

## Design Advantages

- Fabricated discharge head and flanged column.
- Flanged bowl construction.
- 416SS shafting.
- Alloy construction with external flush of critical wear areas available for corrosive/abrasive services.
- Built-in alignment and simple piping for less costly installation and ease of maintenance/ reduced downtime.

## Services

Seawater and River Water Intake

Pressure Boosting

Filter Backwash

General Transfer

Final Effluent

# Cross Sectional MVT-FF (Product Lube)

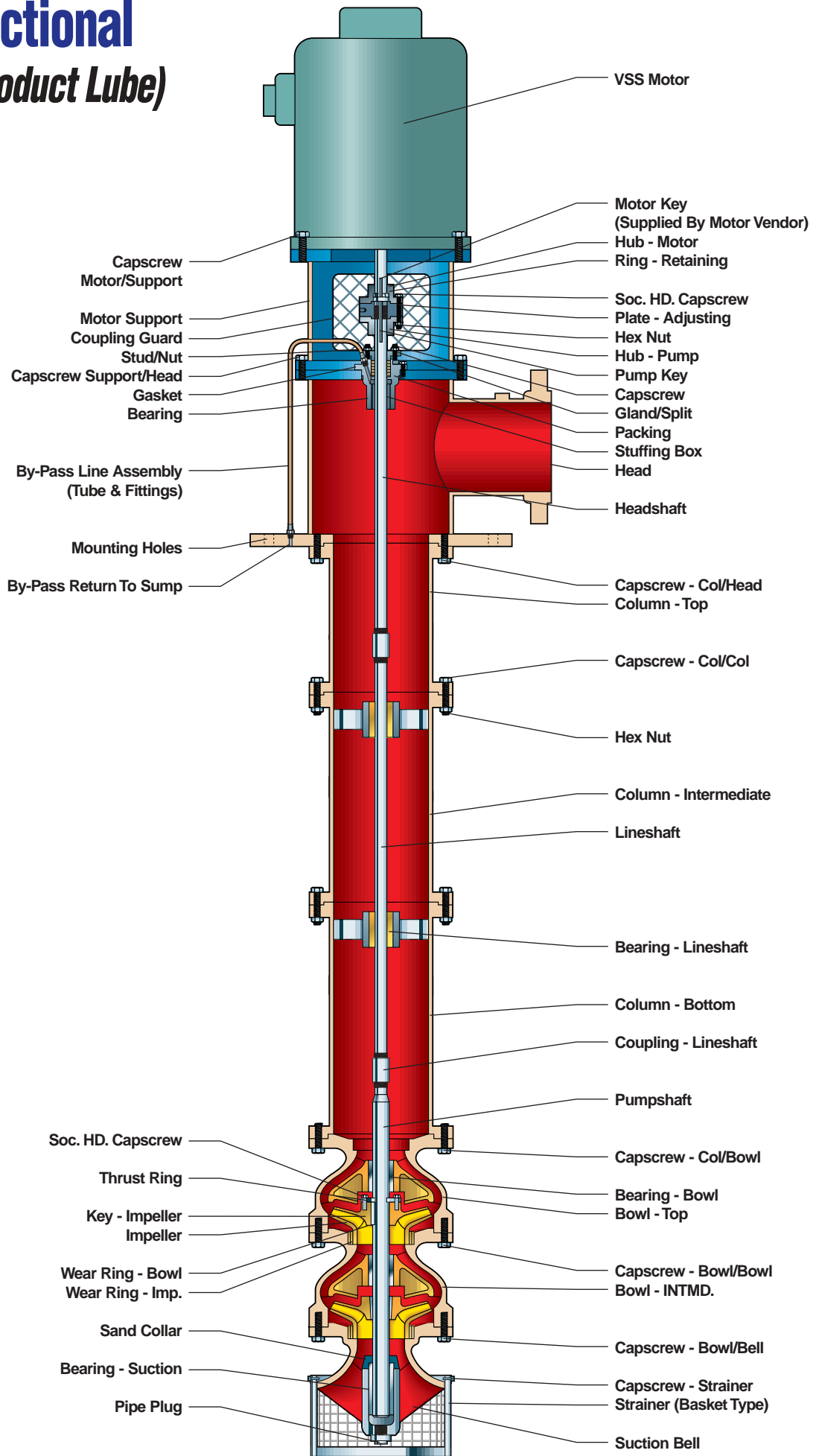

# Cross Sectional MVT-FF (Enclosed Lineshaft)

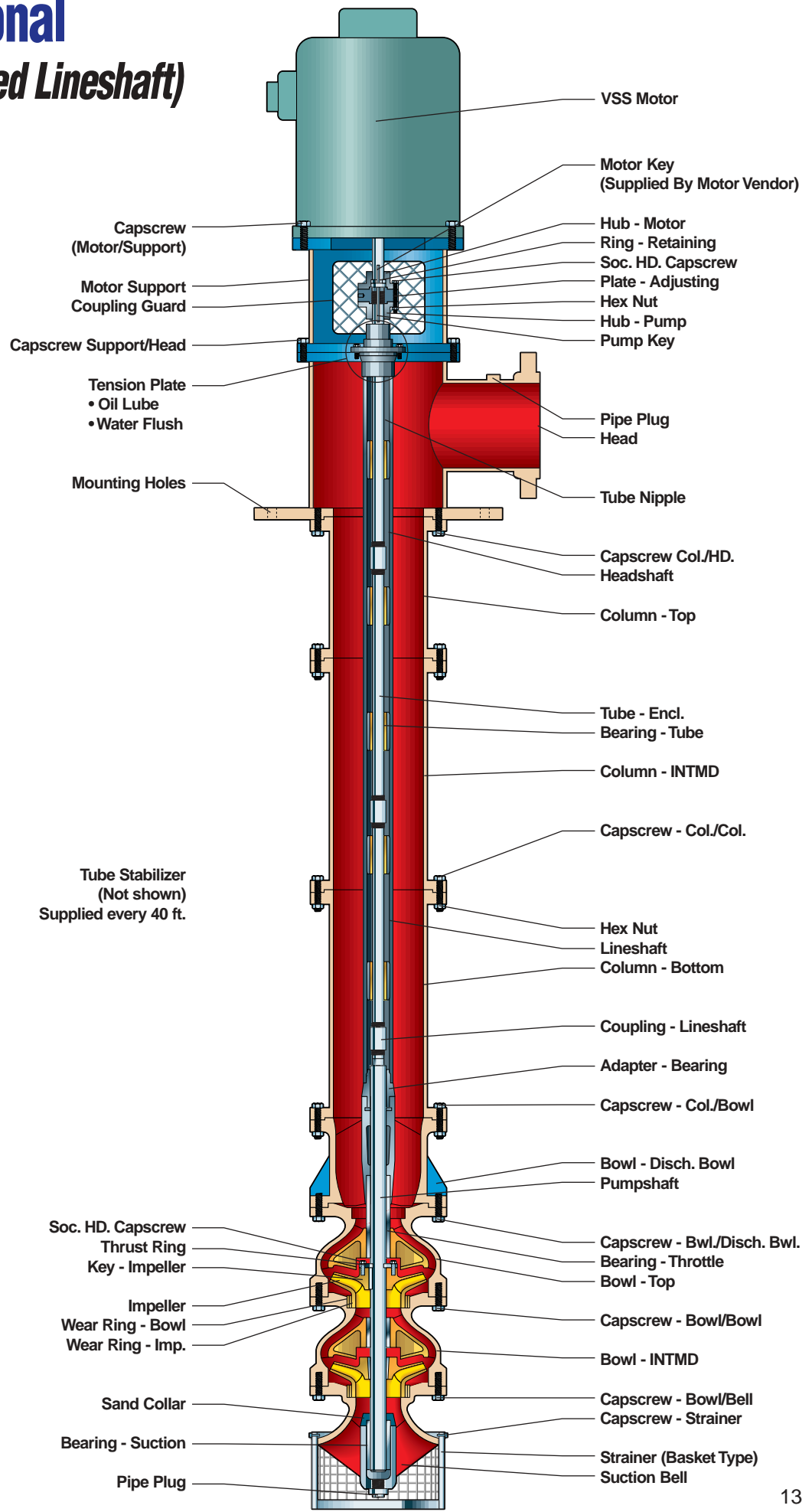



# Model MVC

## Municipal Vertical Can-Type Pump

- Capacities to 65,000 GPM (14,763 m<sup>3</sup>/h)
- Heads to 3,500 feet (1,070m)
- Temperatures cryogenic to 500° F (260° C)
- Bowl sizes from 6" to 55"

## Design Advantages

- Fabricated discharge head.
- Flanged bowl construction.
- 416SS shafting.
- In-line suction and discharge simplifies installation.
- Optional suction in can for flexibility.
- Inherent design features on Model MVC allow efficient operation at any NPSH available.
- Alloy construction for corrosive/abrasive services.
- Refer to pages 6 and 7 for additional bowl assembly features/options.

## Services

Pressure Boosting  
Filter Backwash  
General Transfer  
Final Effluent

# Cross Sectional MVC-T

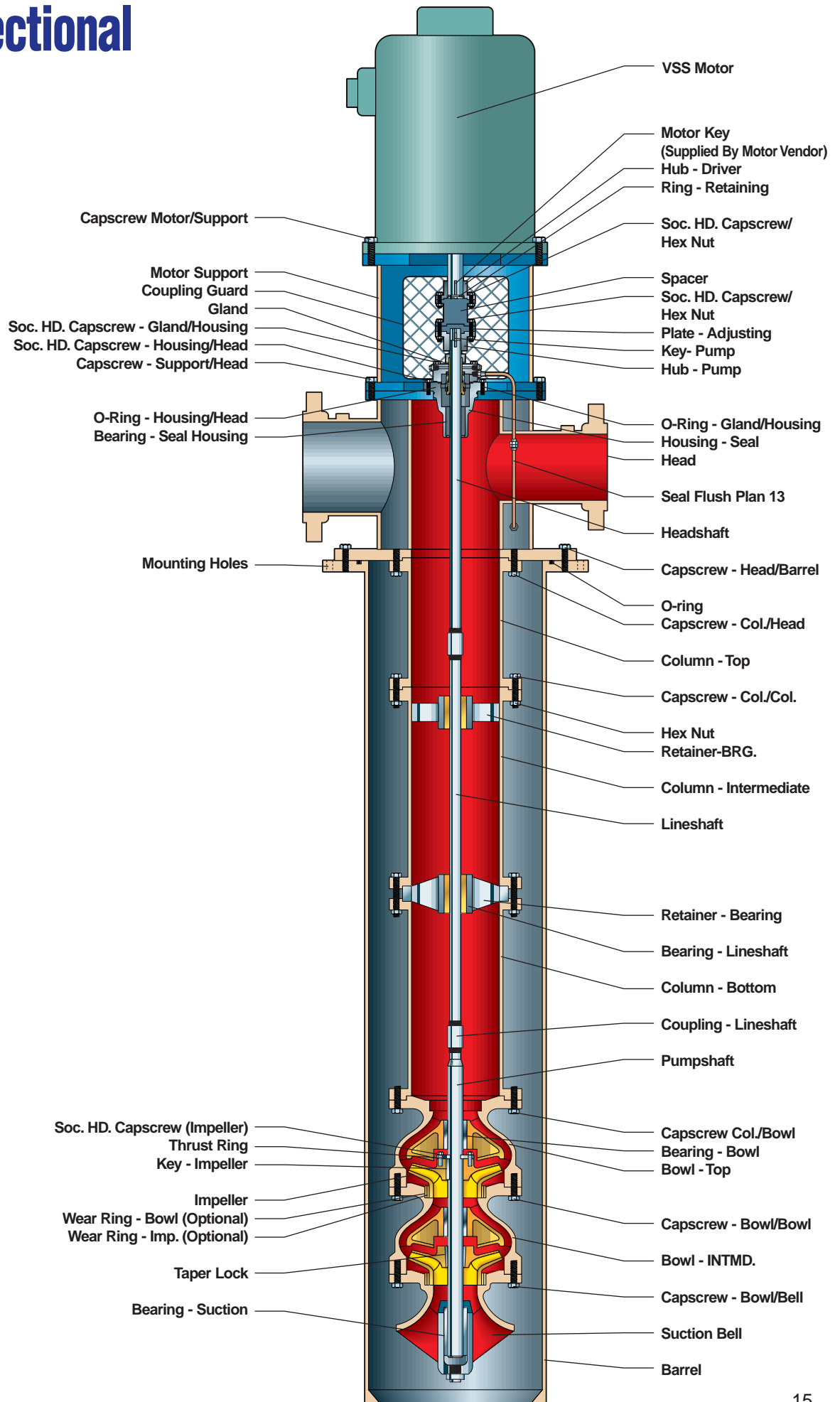



# Model MVS

## Municipal Vertical Submersible Pump

- Capacities to 4,000 GPM (908 m<sup>3</sup>/h)
- Heads to 1,400 feet (427m)
- Bowl sizes from 6" to 20"

## Design Advantages

- Ideal for deep set applications where use of lineshaft pumps is impractical.
- Complete unit is installed underground resulting in quiet operation and space saving.
- Long life/low maintenance — no lubrication, alignment.

## Services

Irrigation  
Service Water  
Deep Well



# Cross Sectional MVS

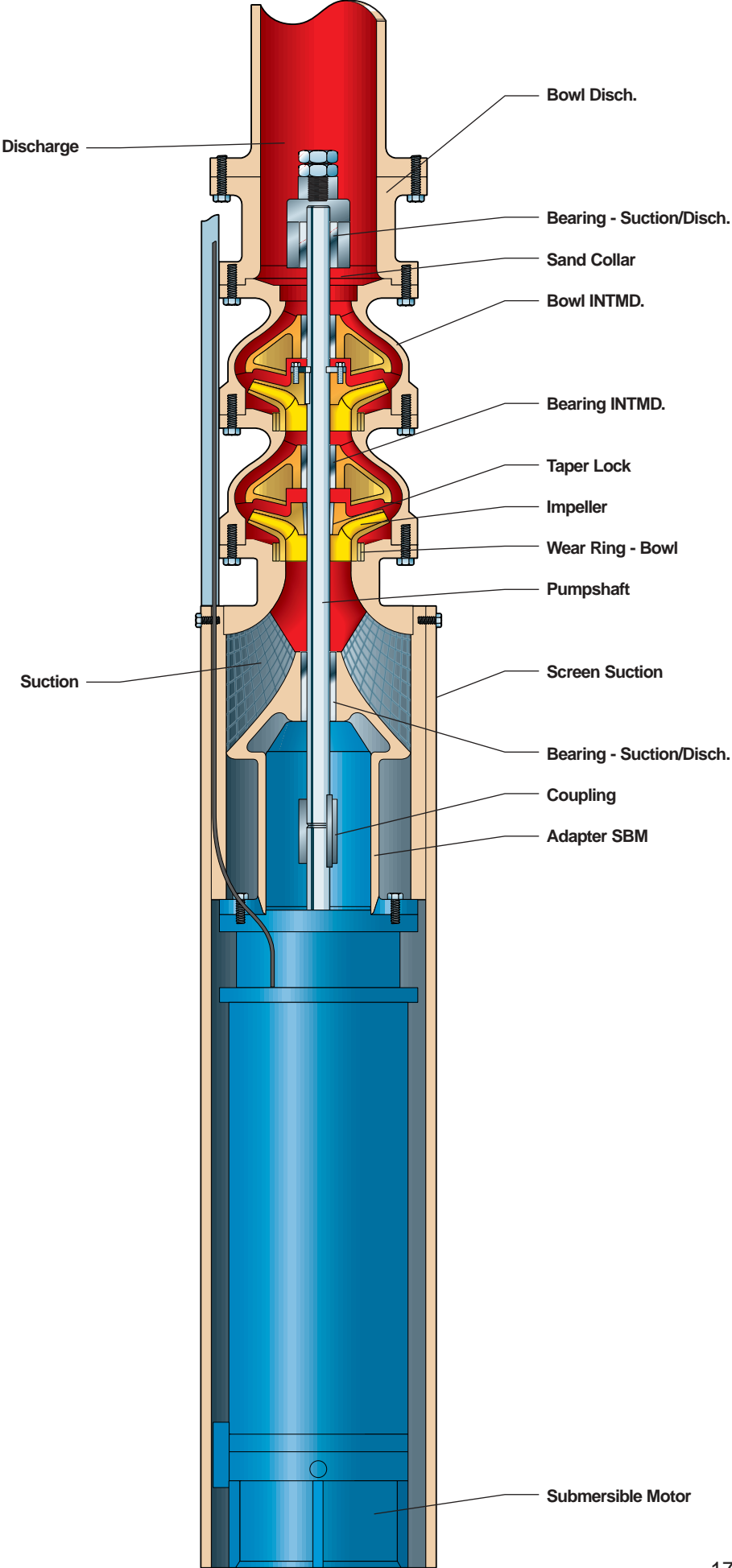

# Other High-Capacity Vertical Pumps from A-C

## Models WCAX, YDD, WCA and WCB

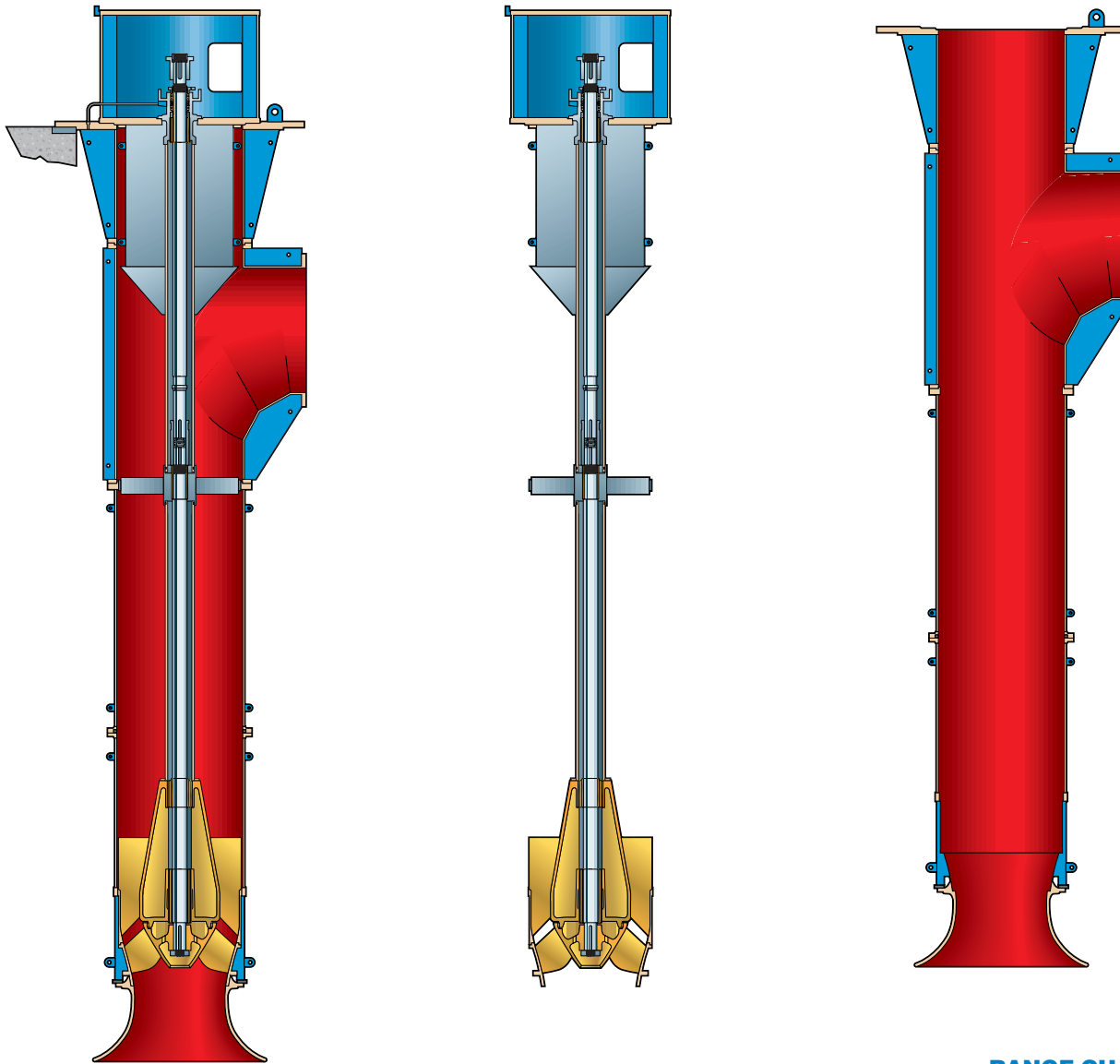

### DESIGN OPTIONS AND FEATURES PROVIDE IMPORTANT COST SAVINGS BENEFITS

Available as an option on all ITT A-C wet-pit pumps, the "pullout" design reduces maintenance costs and downtime as the discharge piping remains undisturbed when removing the pump.

The unique hydraulic thrust relief design (achieved by opening an area behind the impeller to the outside of the pump) results in low thrust values from maximum flow to shutoff head. This reduces the cost of the driver by reducing the size of the required thrust bearing.

To reach high pressure heads the pumps can be arranged for up to a three stage configuration. ITT A-C Pump's advanced hydraulic designs provide some of the highest efficiency pumps available in the pumping industry.



**RANGE CHART**

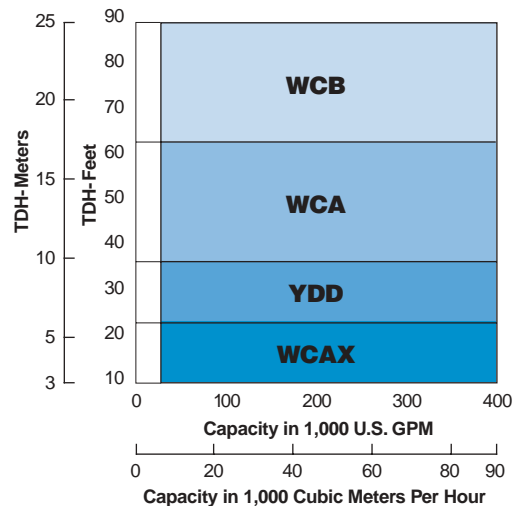

# Models WMCC and WMCE

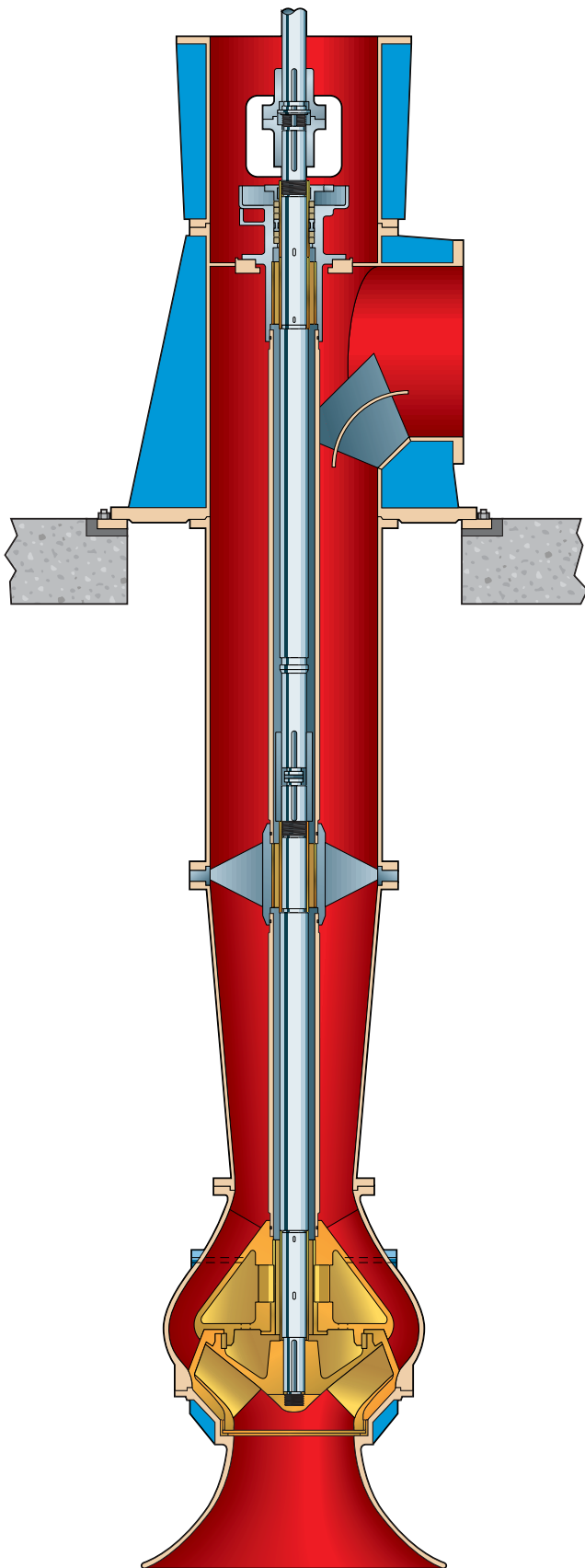

## VERTICAL WET PIT PUMPS OFFER MAXIMUM FLEXIBILITY

The vertical wet pit column pump is the backbone of flood control applications. It has the capability of operating over a wide range of heads, varying suction water levels, and takes a minimum of floor space.

ITT A-C Pump offers several specific speed designs in the axial and mixed flow range to meet a broad range of customer requirements. Mechanical designs are HEAVY-DUTY for long life and reliability.

## RANGE CHART

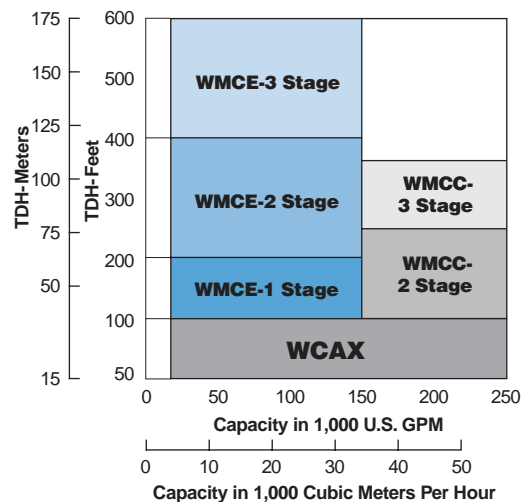



# PRO Services™: Your Business Solution For...

Routine Maintenance ✦ Plant Shutdown ✦ Field Repair  
Contract Services ✦ Turnkey Service



**PRO Service Centers: Worldwide...  
Wherever You Need Us.**



## In The Shop...Or On The Road.

PRO Services engineers and technicians are experienced with servicing all types of pumps and rotating equipment. Customers utilize PRO Services for commissioning, troubleshooting, and field repairs of pumps, pumping systems and other pieces of rotating equipment.

PRO Services engineers and technicians utilize state-of-the-art techniques and equipment to provide the highest level of service in the industry.

- Technical Expertise
- Factory-Trained Service Personnel
- Fast Turnaround
- Emergency Service — 24 hours/day, 7 days/week, 365 days/year
- Quality
- ISO and Safety Certified

**PUMPSMART<sup>®</sup>**  
CONTROL SOLUTIONS

**Simplicity**  
Dedicated pump control and protection logic in a easy to use package

**Reliability**  
Longer pump and seal life means reduced maintenance and downtime

**Control**  
Improved pumping accuracy and repeatability means better process control

**Operating Cost**  
Variable speed cuts energy cost up to 70%

**Flexibility**  
Control any centrifugal pump up to 700 HP

**PUMPSMART**  
CONTROL SOLUTIONS

Visit our website at [www.acpump.com](http://www.acpump.com)

A-C Pump



**ITT Industries**  
*Engineered for life*

