



INNOVATION INSIDE

NEW CR 1, 3, and 5

We've redesigned our CR line for increased economy and performance

Grundfos is known for our strong commitment to research and cutting-edge technology. To that end, we've redesigned our multistage CR pumps. The CR has long been the industry standard for reliability and economy. Even so, important improvements come from talking with the people who work with our pumps every day. We've replaced the CR/CRN 2 and 4 with four pump sizes ideally suited to your applications: CR1s, 1, 3, and 5, all in material versions CR/CRI/CRN. New features you'll appreciate:

A hard-wearing, easy-to-replace cartridge seal minimizes downtime



Superior reliability with added protection against dry-running



More standard connections, including threaded and flanged, plus customized connections.



Unmatched operating economy from state-of-the-art pump efficiency

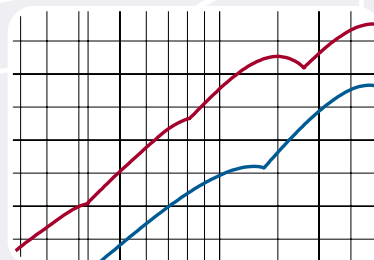

New sizes

We've heard that 15% of CR2 pumps are used for flows under 5 gpm, so we've designed the CR1s with an optimal duty point of 4 gpm.

The new narrower interval between pump sizes and wider range results in a better match with pump capacity, motor size, and system requirements. This cuts investment and operating costs.

New sizes, features, and the available materials provide thousands of possible configurations to ensure you get the right pump for the job.

Connections

We offer additional standard connections, including threaded and flanged, plus victaulic, clamp, and union. Customized connections are available.

Dimensions

Connection dimensions haven't changed and are 100% interchangeable. However, improvements resulted in minor changes in pump height, which could affect your system. We're ready to assist you in the transition to the new CR line.

Conversion software

We've enclosed a CD-ROM with software to help you select the CR that matches your requirements. You can compare the performance and dimensions of the new CR line with those of the CR/CRN 2 and 4. The CD-ROM provides downloadable CAD drawings.

Superior reliability

Dry-running is the most common cause of pump failure. The new Grundfos LiqTec™ pump accessory shuts the pump down the instant it runs dry. Plus, we've improved pump components to better withstand brief periods of dry-running.

Connection options

A broad range of connections match any system requirement.

Oval flange



Flexiclamp

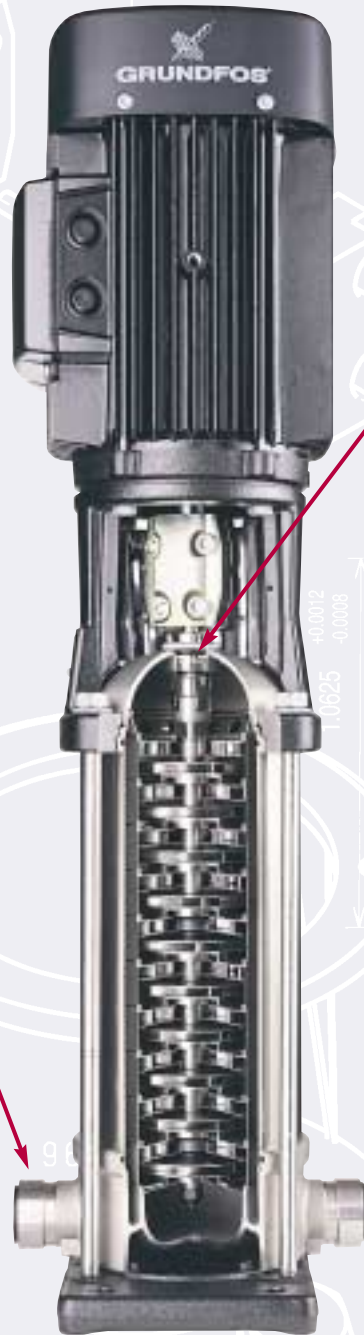

New cartridge seal increases reliability and allows easier access

Hard-wearing materials prolong the life of the seal and minimize downtime for your system. Seal components are combined into a single cartridge unit for fast replacement when the seal finally wears out.

With the cartridge seal, there's no risk of assembling seal components incorrectly. Plus, the seal surfaces are protected against impurities.

Unmatched operating economy

85% of the cost of owning and operating a pump is for the electricity to run it. Redesigning our CR pumps resulted in a 10% increase in efficiency and a resulting decrease in power consumption costs.

Everything you need is in this brochure:

Performance curves

We've included performance curves for each of the new pumps compared with the CR/CRN 2 and 4. See the following pages for:

CR/CRI/CRN 50 and 60 Hz

CR 2 / CR 1s

CR 2 / CR 1

CR 2 / CR 3

CR 4 / CR 3

CR 4 / CR 5

Pump conversion software

Inside back cover holds a downloadable CD with details on the redesigned CR line.

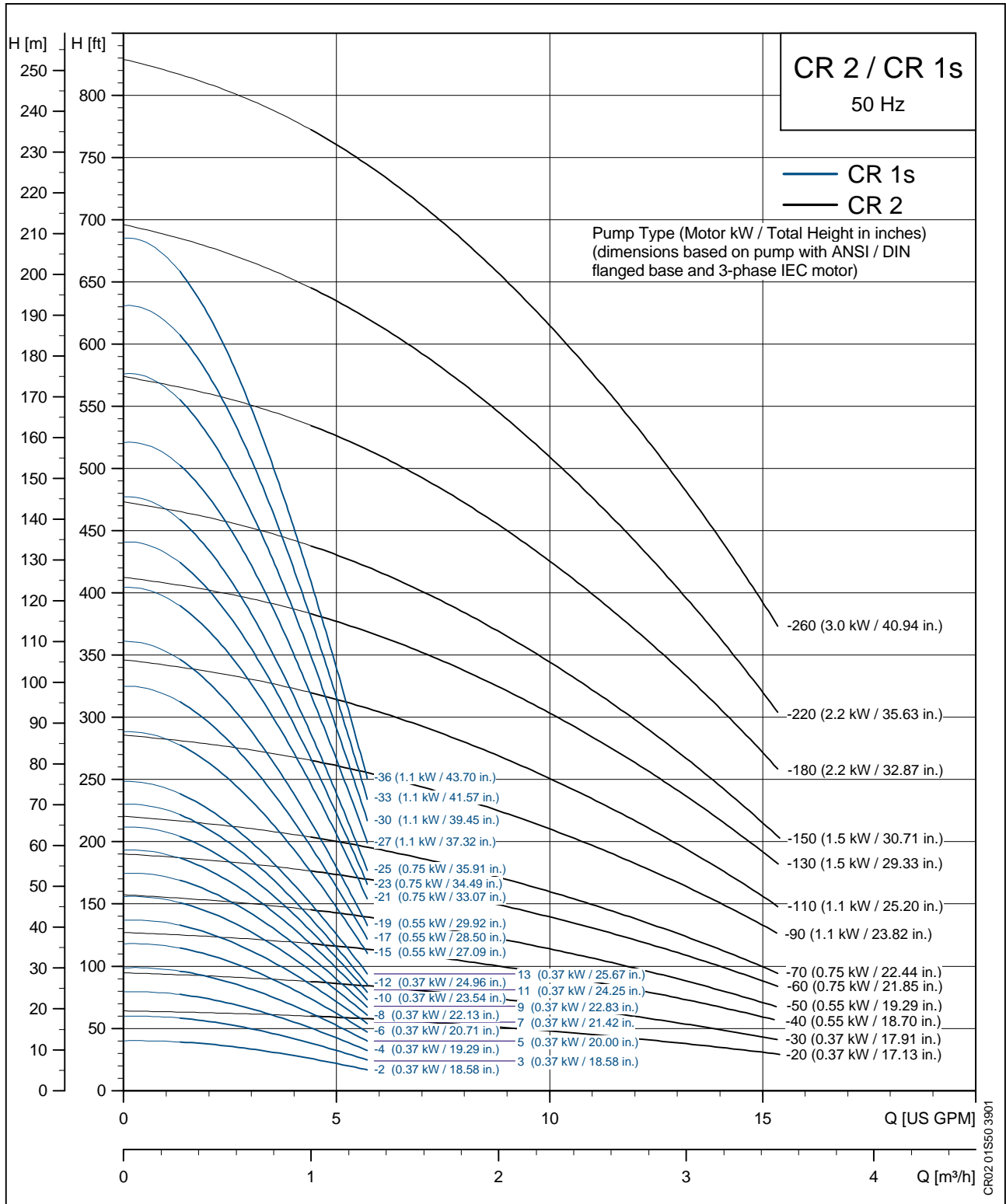

PERFORMANCE CR 2/CR 1 50 Hz

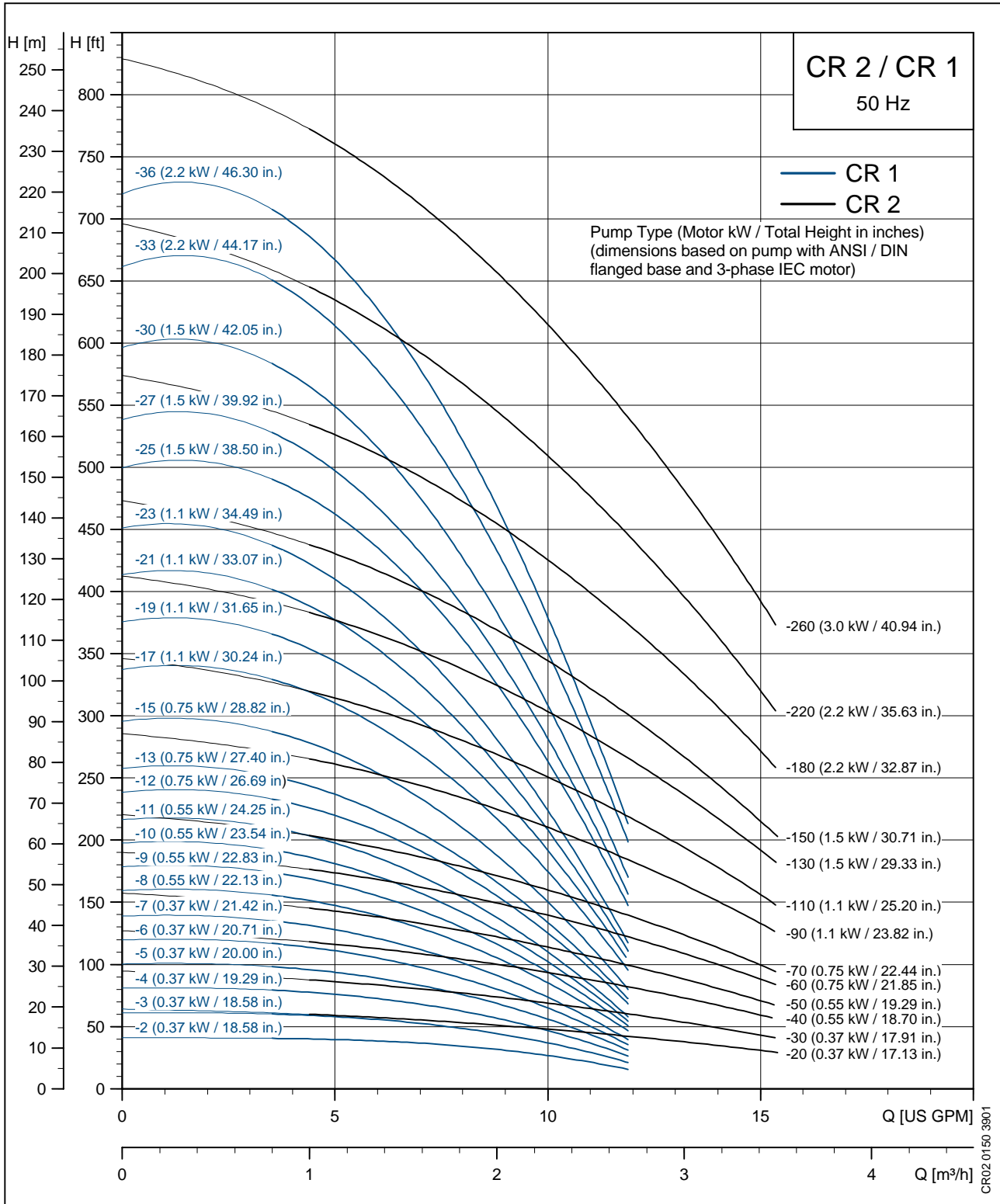

PERFORMANCE CR 4/CR 3 50 Hz

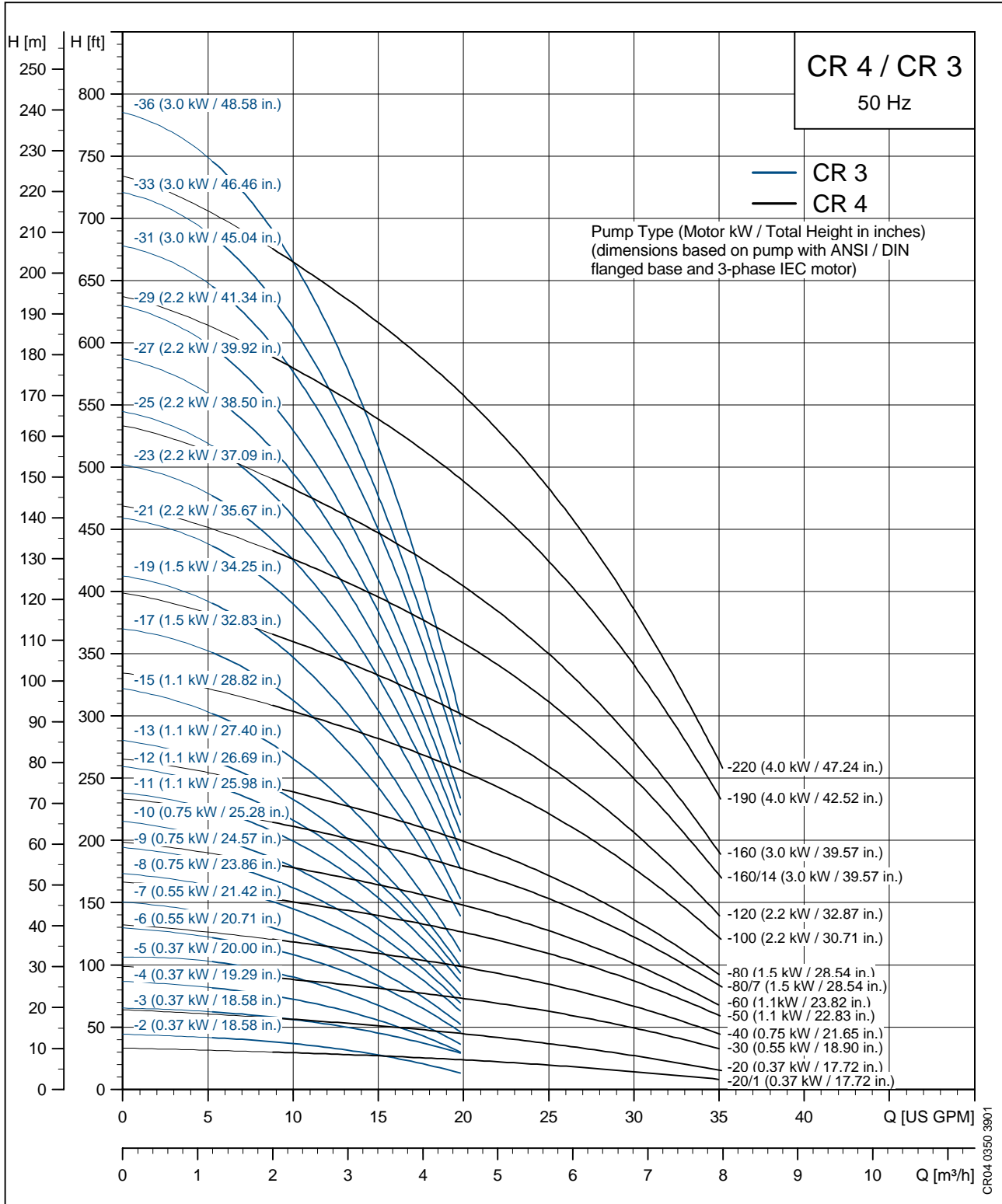

PERFORMANCE CR 4/CR 5 50 Hz

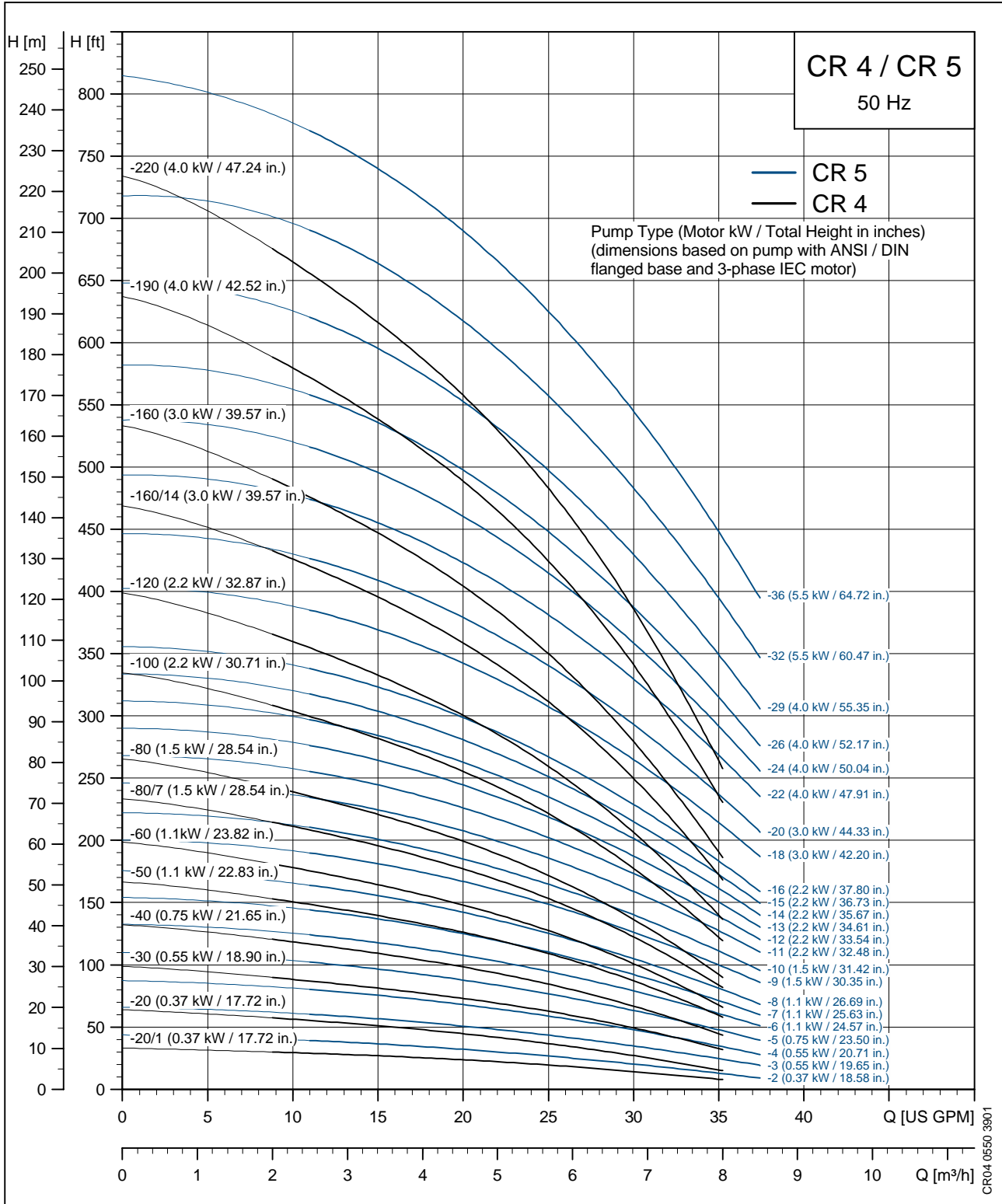

PERFORMANCE CR 2/CR 1s 60 Hz

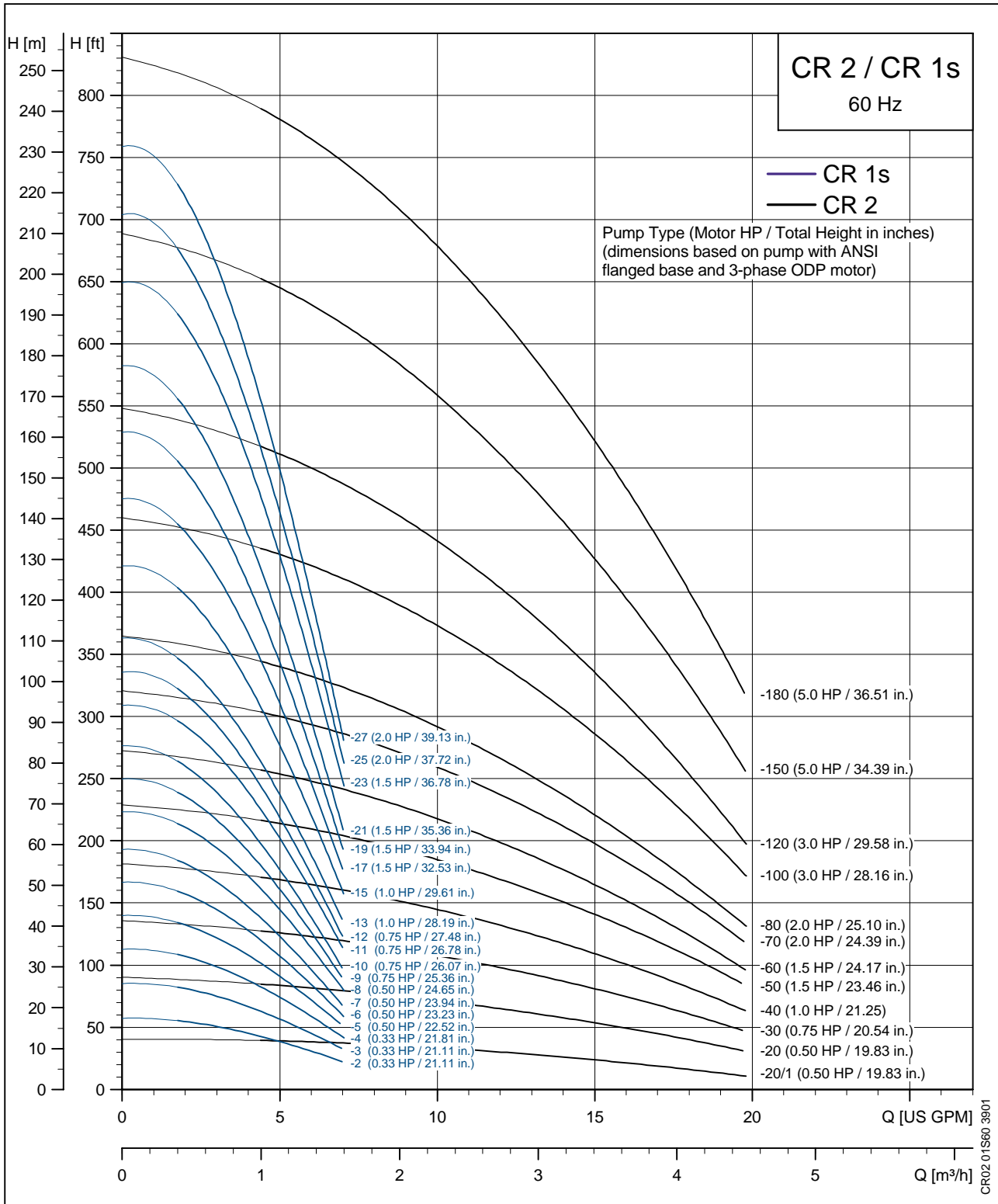

PERFORMANCE CR 2/CR 1 60 Hz

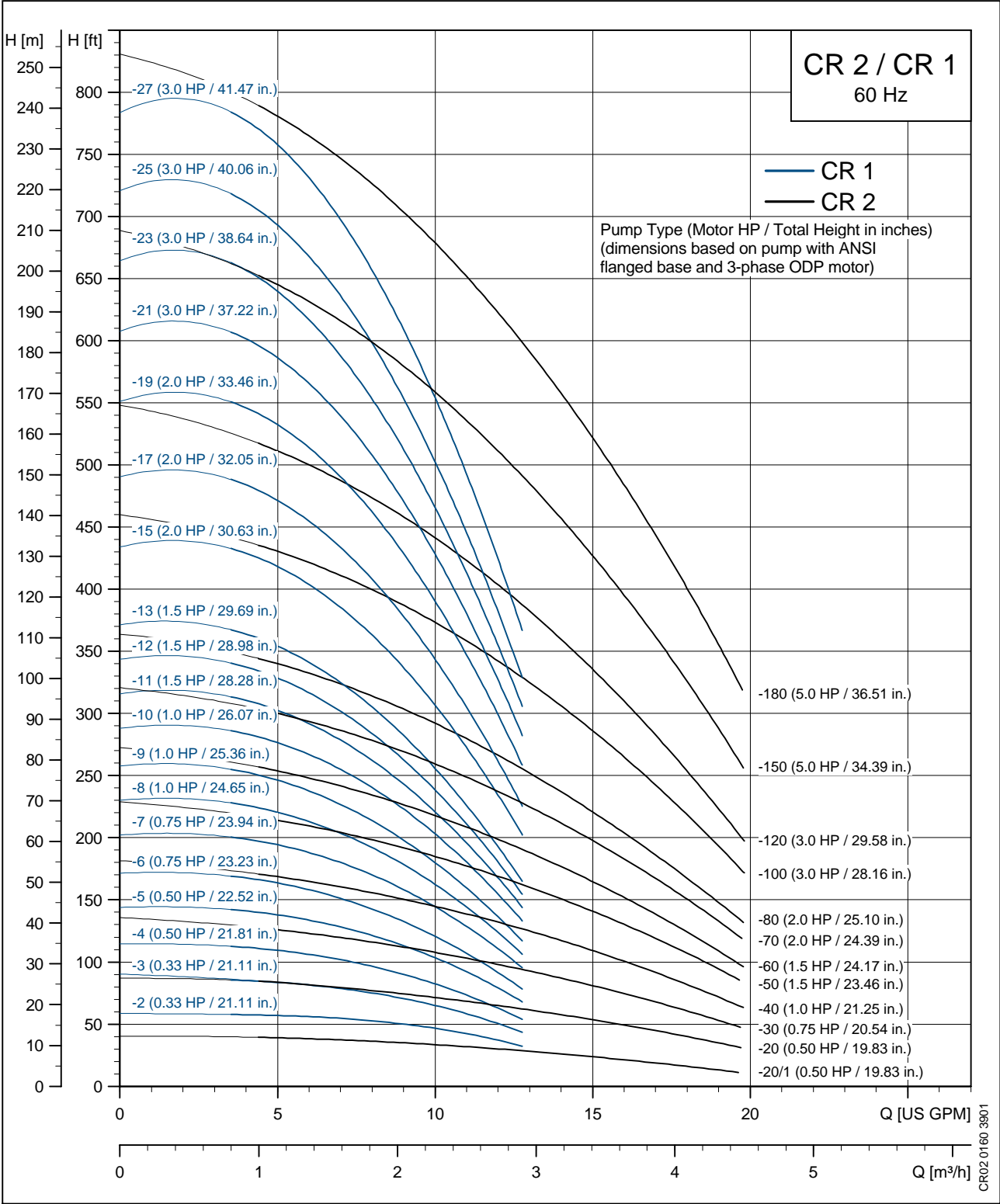

PERFORMANCE CR 2/CR 3 60 Hz

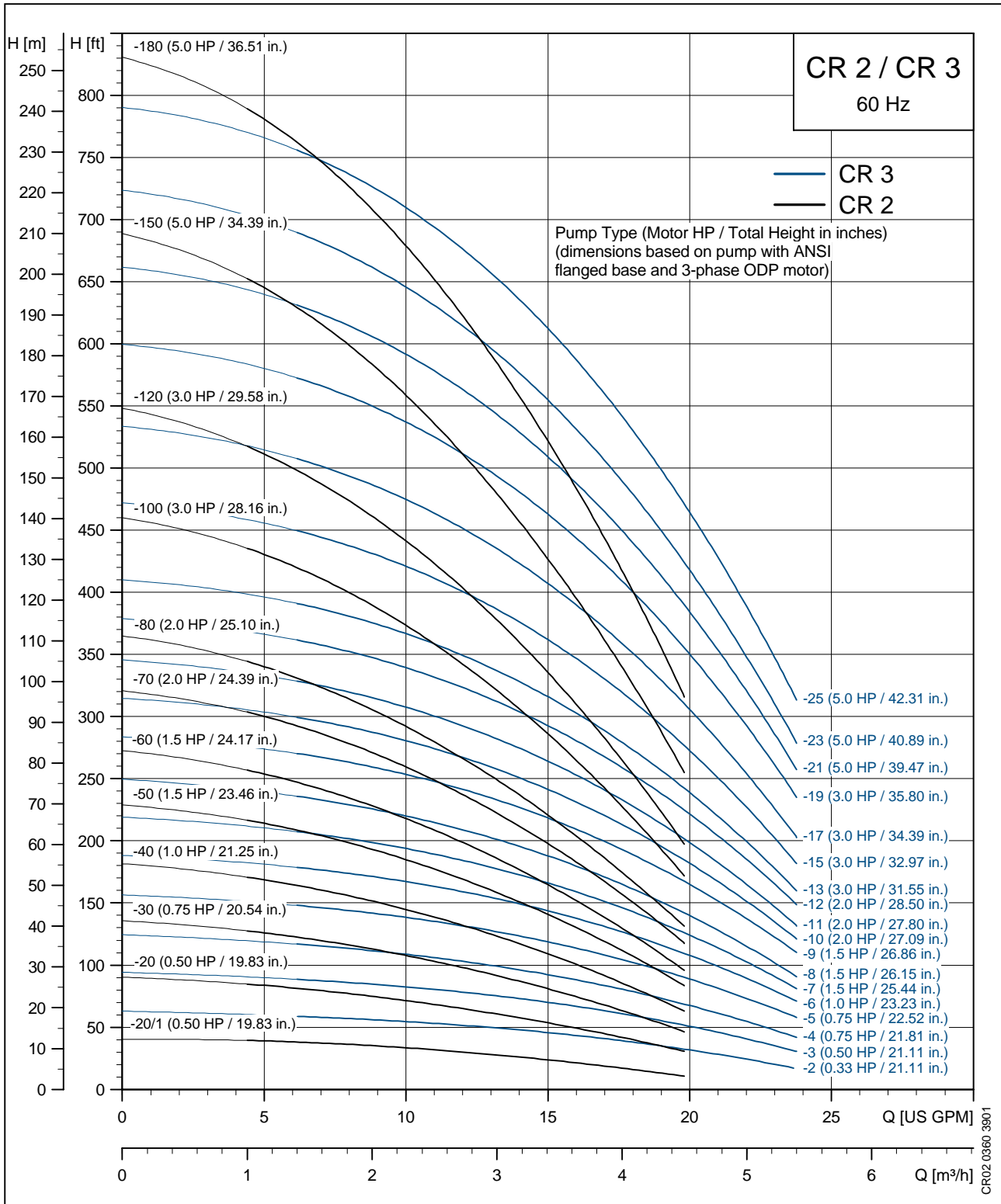

PERFORMANCE CR 4/CR 3 60 Hz

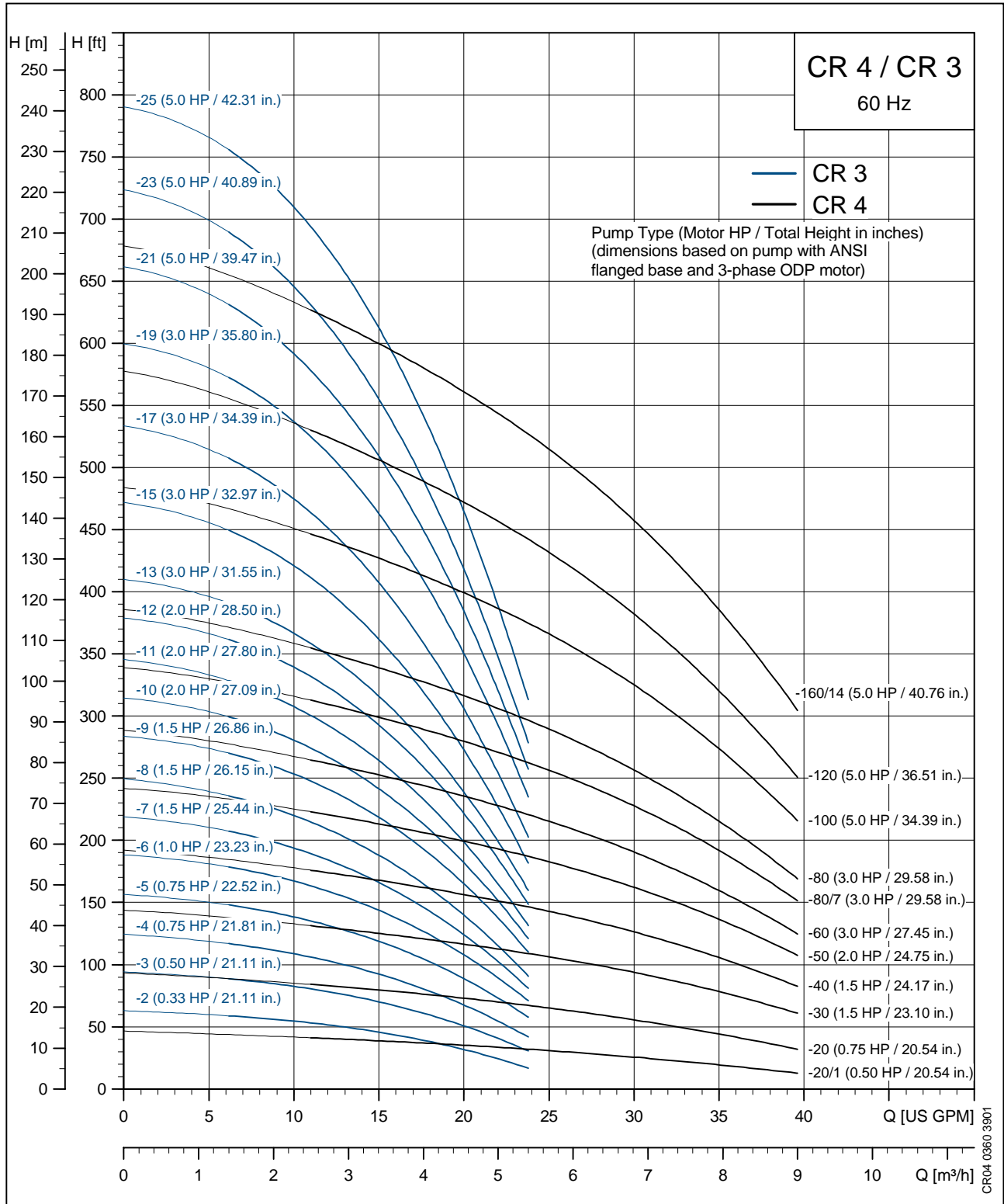

PERFORMANCE CR 4/CR 5 60 Hz

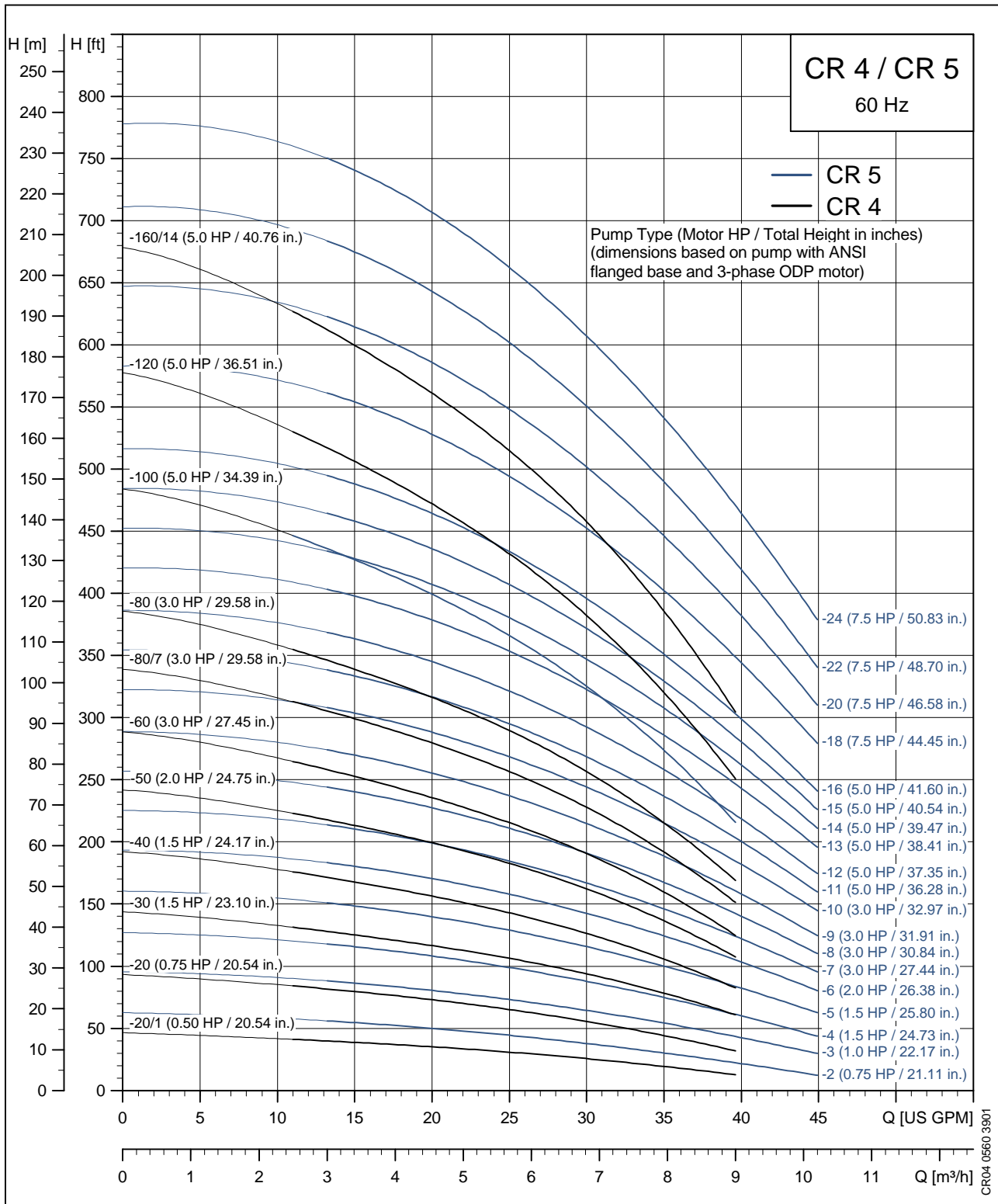

Pump conversion software

Load the CD-ROM onto your computer and follow the instructions that appear on your screen. Within seconds you will have details on the redesigned CR line.

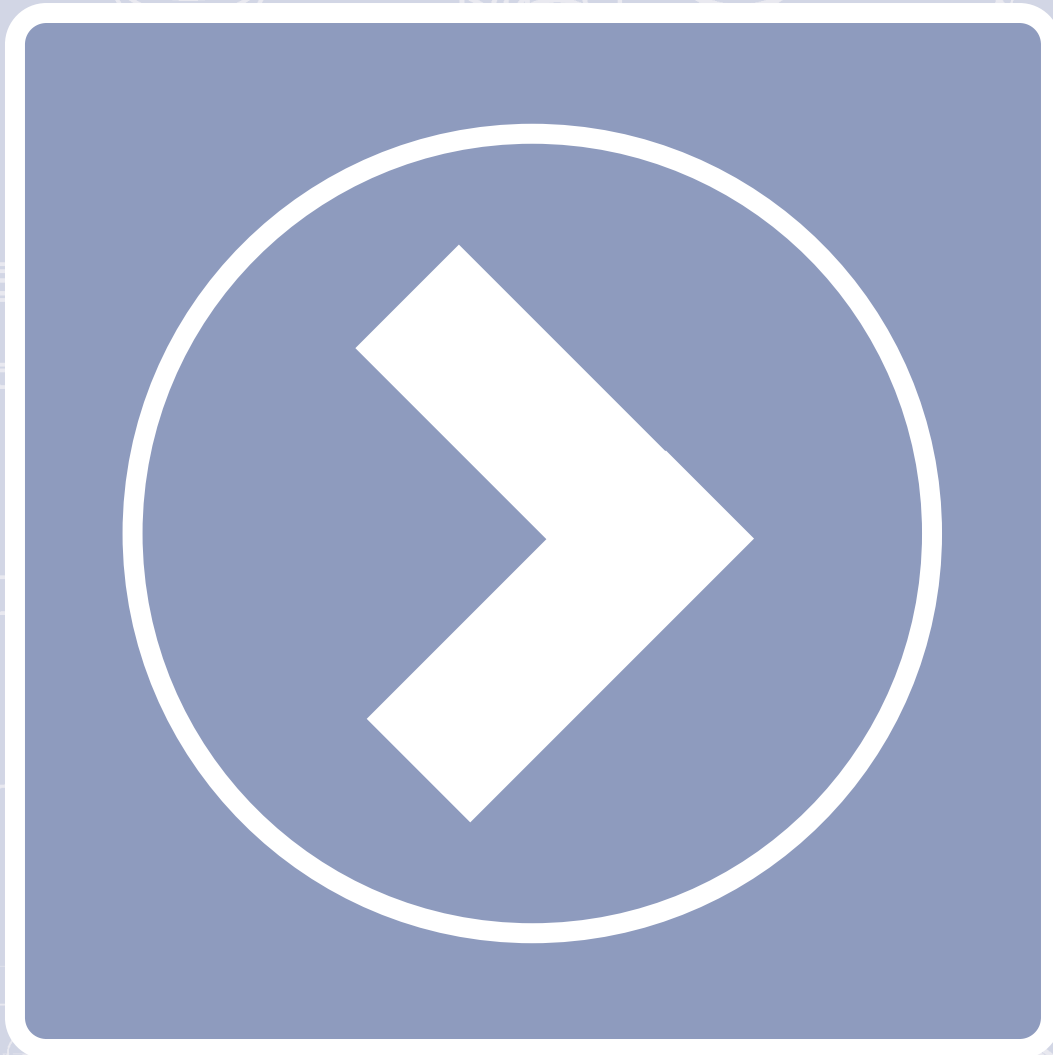

Enter the pump type, flow and connection type of your existing CR. Click “Choose new pump.”

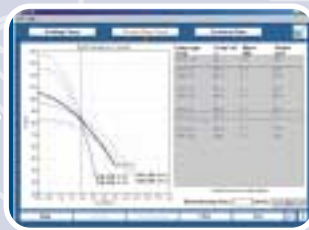

Consult the performance curves and select the new CR which best matches your needs from the list. Click “Technical Data.”

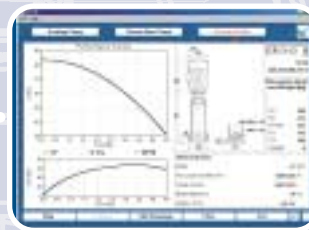

Technical data and exportable CAD drawings are presented here.

Innovation inside: Grundfos new CR

Grundfos engineers gave our CR pumps a makeover:

- **Four new CR pumps** make it easier for you to find the right pump size
- **A redesigned cartridge seal** integrates seal components into a single unit that's easy to replace
- **Hard-wearing materials** prolong the life of the seal and the pump itself
- **Our new LiqTec™ dry-run detector** shuts down the pump before damage occurs
- **Increased reliability and operating economy** give you more peace of mind

We're proud to introduce a new generation of our pioneering CR pumps you and your customers will appreciate.

L-CR-SL-002 10/01
PRINTED IN USA