

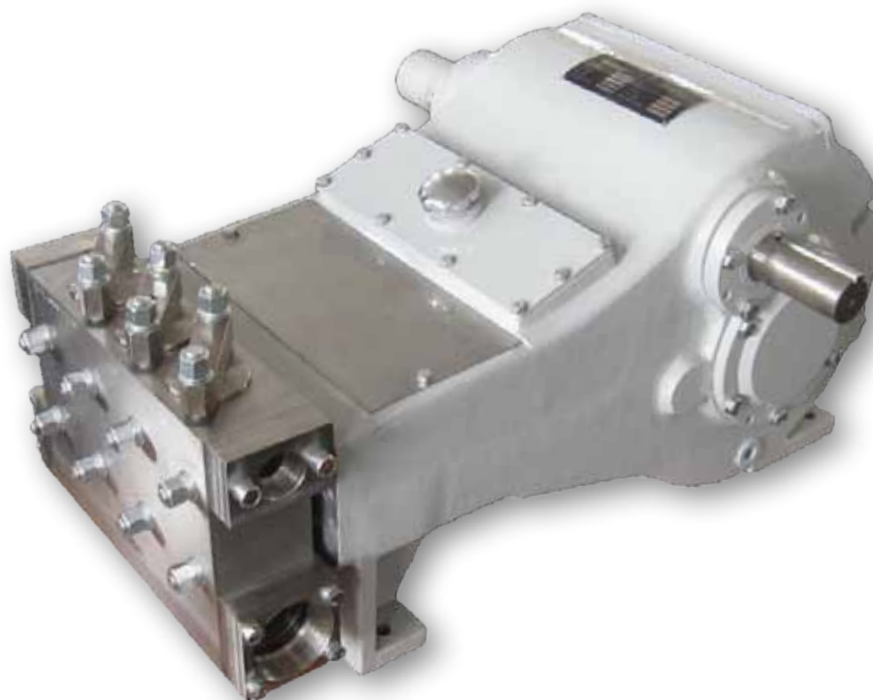

Model T40 Triplex Power Pump

Weatherford's Model T40 is a single-acting triplex plunger pump rated at 41 HP in continuous-duty service and up to 66 HP in intermittent duty. This versatile pump is offered with a variety of material and design options that allow it to be used in a wide range of applications.



Applications

- Amine gas sweetening
- Ammonia
- Chemical injection
- Core drilling
- Crude transfer
- Detergent and soap slurries
- Dust suppression
- Glycol gas dehydration
- High-pressure washdown
- Horizontal directional drilling
- Hot-oil truck injection
- Hydrostatic testing
- Light hydrocarbon transportation
- Machine tool coolant
- Methanol injection
- Municipal jetting
- Polymer flood
- Produced water disposal
- Pulp and paper
- Reverse osmosis
- Secondary recovery
- Steam boiler feed
- Steel mill descaling
- Water injection



Model T40 Triplex Power Pump

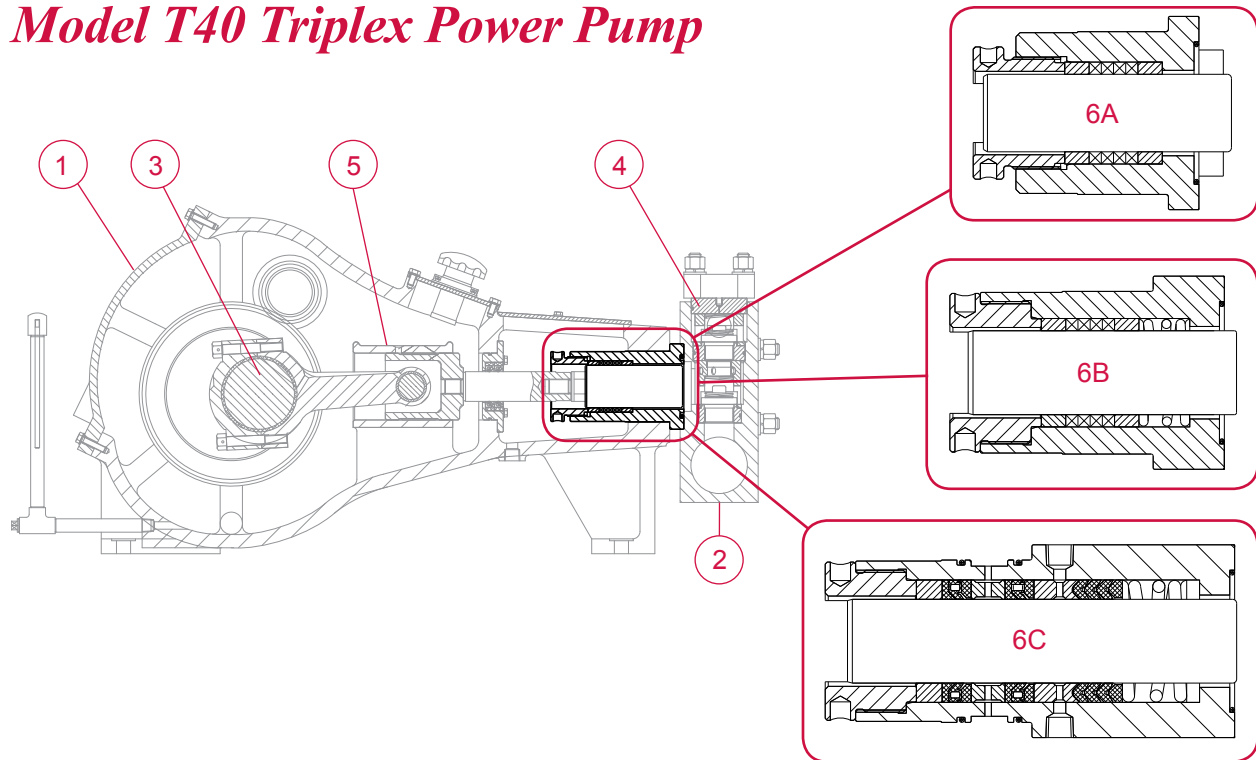

Features, Advantages and Benefits

1. The graphite flake microstructure of the cast iron power frame ensures robust, fatigue-free durability and excellent wear resistance of moving surfaces.
2. All fluid cylinders are made from forged carbon steel, duplex stainless-steel, or nickel-aluminum-bronze material for increased durability and extended life. Cast materials are never used as they are susceptible to internal defects resulting from solidification shrinkage during casting.
3. Critical components—crankshafts, connecting rods, crossheads, and bearings—are comparatively larger than industry-standard components, enabling them to withstand continuous duty service and harsh operating conditions.
4. Stacked valve assemblies use O-ring seals on the seats, allowing easy accessibility for quicker service.
5. The oil trough is designed to evenly lubricate the crossheads and wrist-pin bearings during operation to reduce wear and extend component life. Pump vendors often exclude this critical feature to simplify the design and reduce the cost of the power end.
6. A variety of packing arrangements are available to meet the requirements of any applications:
 - a. Standard, manually adjustable packing.
 - b. Optional spring-loaded packing does not require manual adjustment.
 - c. Optional stuffing box design that minimizes fluid and vapor leakage to atmosphere for critical fluids.

Model T40 Triplex Power Pump

Specifications

Plunger Ratings

Pump Model	Plunger Size (in./mm)	Displacement (Gal/Rev)	Rated Pressure (psi/MPa)	Rated Capacity (GPM/BPD)		
				Minimum	Continuous	Intermittent
T40A	1.000 25	0.0096	4,480 30.89	2.7 93	8.4 288	13.6 465
	1.250 32	0.0149	4,480 30.89	4.3 146	13.1 451	21.2 727
	1.500 38	0.0215	3,110 21.44	6.1 210	18.9 649	30.5 1,047
T40B	1.750 45	0.0293	2,290 15.79	8.3 286	25.8 883	41.6 1,426
	2.000 51	0.0382	1,750 12.07	11.0 374	34.0 1,154	54.0 1,862
	2.250 57	0.0484	1,380 9.515	14.0 473	43.0 1,460	69.0 2,357
	2.500 64	0.0598	1,120 7.722	17.0 584	53.0 1,803	85.0 2,909

	Continuous Duty	Intermittent Duty
Rated power (HP)	41	66
Maximum speed (RPM)	880	1,420
Minimum speed (RPM)	285	

Stroke length (in./mm)	2.95 75
Rated rod load (lb/kg)	5,500 2,500
Weight (lb/kg)	945 430
Oil capacity (qt/L)	21.4 20.3
Maximum fluid temperature (°F/°C)	180 82
Gear reduction ratio	3.15:1
Mechanical efficiency	85%

Model T40 Triplex Power Pump

Selection Graph

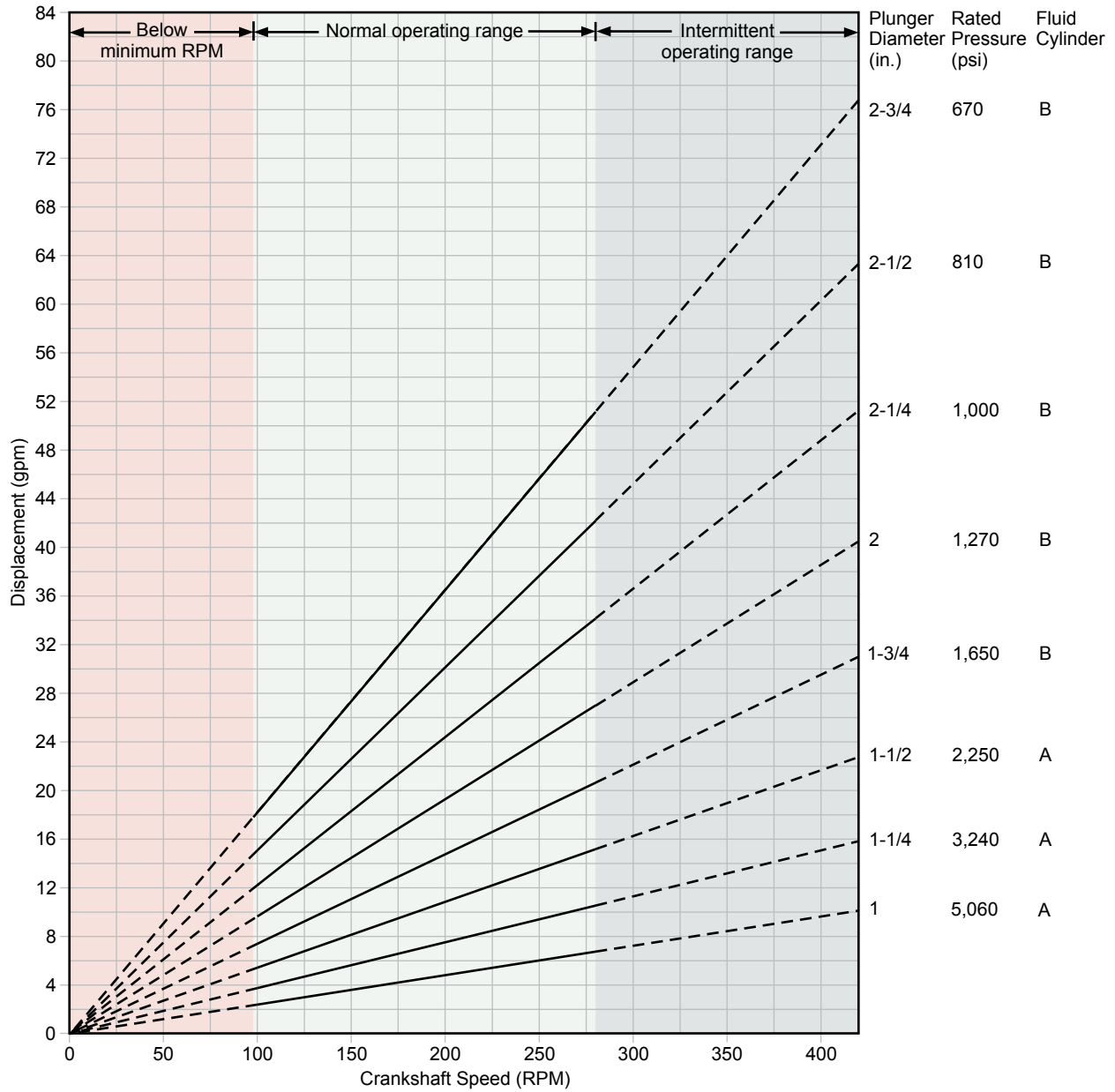

2.95-in. stroke, maximum rod load 5,500 lb (2,495 kg)



Model T40 Triplex Power Pump

General Dimensions

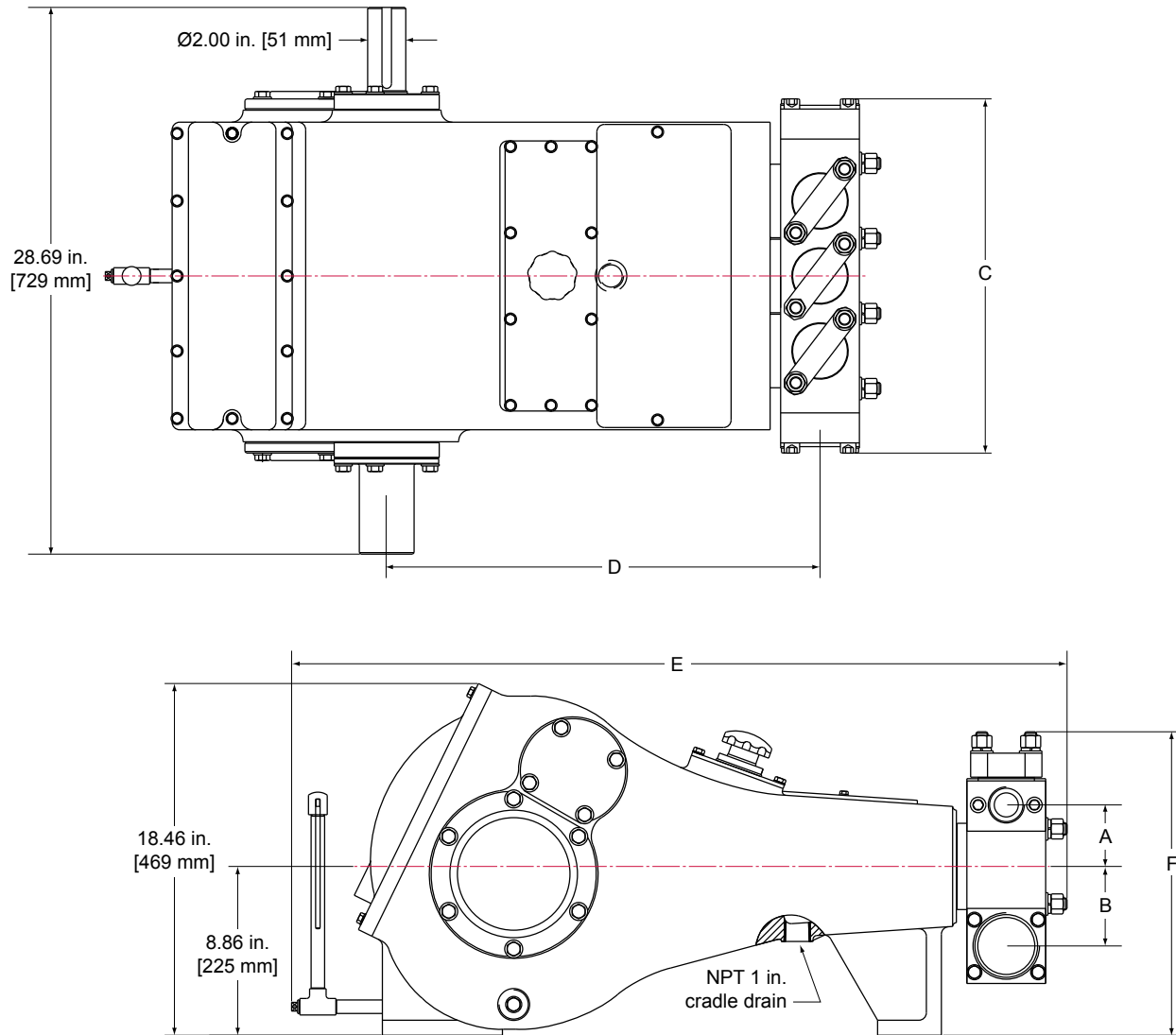

Pump Model	Flange Connections (in./mm)		Dimensions (in./mm)					
	Discharge Connection Sizes	Suction Connection Sizes	A	B	C	D	E	F
T40A	1 (25.4) NPT	2 (50.8) NPT	3.23	4.17	18.62	25.85	40.87	16.11
T40B	1-1/2 (38.1) NPT	3 (76.2) NPT	82	106	473	656	1,038	409



Model T40 Triplex Power Pump

Materials of Construction

Fluid Cylinder—The T40 pump is offered with 4140 carbon steel, 955 nickel-aluminum bronze, and 2205 duplex stainless-steel fluid cylinder materials, as standard, with 420, 304, and 316L stainless-steel materials available on special request.

Plungers—Weatherford provides tungsten carbide coated plungers as standard on all versions of the T40 pump. Weatherford can offer optional solid ceramic, or ceramic coated plungers on request for special applications with pumping abrasive or corrosive fluids for superior durability.

Packing—Weatherford provides all T40 pumps with braided Teflon®-Kevlar® packing as standard. This versatile packing is suitable for a wide variety of fluids and can work with or without external lubrication in most services. Optional packing styles and materials may be available as options to provide maximum performance and durability for almost any fluid and operating condition.

Trim Rings—Trim rings located inside the stuffing box may include throat bushings, lantern glands, follower rings, and adjusting nuts. Weatherford provides bronze trim rings as standard on all pumps; however, optional materials are available to meet the needs of specific fluids. All iron trim rings are offered when pumping amines or fluids that contain H₂S.

Seals—The T40 pump is provided with HNBR O-ring seals as standard. This versatile material is compatible with a wide range of common industrial and oilfield fluids and has excellent temperature and abrasion resistant properties. Weatherford can offer Viton®, Aflas®, and EPDM compounds as options to meet specific fluid compatibility and operating temperature requirements.

Special Notes

1. Capacities shown are based on 100% volumetric efficiency. Actual capacities will be lower based on discharge pressure and fluid compressibility.
2. Operating power required by the pump is calculated by the formula: $HP = (\text{psi} \times \text{gpm}) / 1,450$, where psi the actual operating pressure in psi units and gpm is the actual pumping capacity in gpm.
3. Maximum operating speeds are listed are based on pumping non-abrasive fluids with viscosities similar to water. Consult Weatherford for operating speed recommendations for viscous or abrasive liquids.
4. Dimensions shown are typical and should not be used for fabrication purposes. Optional flanged connections shown for reference. Inlet and discharge connections can be on either side of the fluid cylinder.
5. Special designs and materials available for operation above 180°F (82°C).
6. API-674 and NACE-compliant designs available on request. Consult Weatherford for specific details and exceptions to these standards.
7. Standard plunger sizes are shown; however, other sizes may be available on request. Consult Weatherford for performance and pressure ratings.
8. Consult Weatherford for assistance with pump selection on applications where actual operating inlet pressures will be greater than 5% of the rated discharge pressure of the pump model selected.

Teflon, Kevlar, Viton and Aflas are registered trademarks of their respective owners.